

# Drive<sup>IT</sup> Low Voltage AC Drives

## User's Manual

ACS550-01 Drives (0.75...110 kW)

ACS550-U1 Drives (1...150 HP)



**ABB**

## ACS550 Drive Manuals

### GENERAL MANUALS

---

#### ACS550-01/U1 User's Manual (0.75...110 kW) / (1...150 HP)

- Safety
- Installation
- Start-Up
- Embedded Fieldbus
- Fieldbus Adapter
- Diagnostics
- Maintenance
- Technical Data

#### ACS550-02/U2 User's Manual (110...355 kW) / (150...550 HP)

- Safety
- Installation
- Start-Up
- Diagnostics
- Maintenance
- Technical Data

#### ACS550 Technical Reference Manual

(available in electronic format only)

- Detailed Product Description
  - Technical product description including Dimensional drawings
  - Cabinet mounting information including power losses
  - Software and control including complete parameter descriptions
  - User interfaces and control connections
  - Complete options descriptions
  - Spare parts
  - Etc.
- Practical Engineering Guides
  - PID & PFC engineering guides
  - Dimensioning and sizing guidelines
  - Diagnostics and Maintenance information
  - Etc.

### OPTION MANUALS

---

(Fieldbus Adapters, I/O Extension Modules etc., manuals delivered with optional equipment)

Relay Output Extension Module (typical title)

- Installation
- Start-Up
- Diagnostics
- Technical Data

The Industrial<sup>IT</sup> wordmark and Product names in the form Drive<sup>IT</sup> are registered or pending trademarks of ABB.

CANopen is a registered trademark of CAN in Automation e.V.

ControlNet is a registered trademark of ControlNet International.

DeviceNet is a registered trademark of Open DeviceNet Vendor Association.

DRIVECOM is a registered trademark of DRIVECOM User Organization.

Interbus is a registered trademark of Interbus Club.

LonWorks is a registered trademark of Echelon Corp.

Metasys is a registered trademark of Johnson Controls Inc.

Modbus and Modbus Plus are registered trademarks of Schneider Automation Inc.

Profibus is a registered trademark of Profibus Trade Org.

Profibus-DP is a registered trademark of Siemens AG.

# Safety

---



**Warning!** The ACS550 adjustable speed AC drive should **ONLY** be installed by a qualified electrician.



**Warning!** Even when the motor is stopped, dangerous voltage is present at the Power Circuit terminals U1, V1, W1 and U2, V2, W2 and, depending on the frame size, UDC+ and UDC-, or BRK+ and BRK-.



**Warning!** Dangerous voltage is present when input power is connected. After disconnecting the supply, wait at least 5 minutes (to let the intermediate circuit capacitors discharge) before removing the cover.



**Warning!** Even when power is removed from the input terminals of the ACS550, there may be dangerous voltage (from external sources) on the terminals of the relay outputs R01...R03.



**Warning!** When the control terminals of two or more drive units are connected in parallel, the auxiliary voltage for these control connections must be taken from a single source which can either be one of the units or an external supply.



**Warning!** The ACS550-01/U1 is not a field repairable unit. Never attempt to repair a malfunctioning unit; contact the factory or your local Authorized Service Center for replacement.



**Warning!** The ACS550 will start up automatically after an input voltage interruption if the external run command is on.



**Warning!** The heat sink may reach a high temperature. See "Technical Data" on page 216.



**Warning!** If the drive will be used in a floating network, remove screws at EM1 and EM3 (Frame size R1...R4), or F1 and F2 (Frame size R5 or R6). See diagrams on page 15 and page 16 respectively. Also see "Unsymmetrically Grounded Networks" and "Floating Networks" on page 224.



**Warning!** Do not attempt to install or remove EM1, EM3, F1 or F2 screws while power is applied to the drive's input terminals.

---

**Note!** For more technical information, contact the factory or your local ABB sales representative.

---

## Use of Warnings and Notes

There are two types of safety instructions throughout this manual:

- Notes draw attention to a particular condition or fact, or give information on a subject.
- Warnings caution you about conditions which can result in serious injury or death and/or damage to the equipment. They also tell you how to avoid the danger. The warning symbols are used as follows:



**Dangerous voltage warning** warns of high voltage which can cause physical injury and/or damage to the equipment.



**General warning** warns about conditions, other than those caused by electricity, which can result in physical injury and/or damage to the equipment

# Table of Contents

---

## **Safety**

Use of Warnings and Notes .....	4
---------------------------------	---

## **Table of Contents**

## **Installation**

Installation Flow Chart .....	7
Preparing for Installation .....	8
Installing the Drive .....	11

## **Start-Up**

Control Panels .....	27
Assistant Control Panel .....	27
Basic Control Panel .....	37
Application Macros .....	42
Complete Parameter List for ACS550 .....	53
Complete Parameter Descriptions .....	65

## **Embedded Fieldbus**

Overview .....	149
Planning .....	150
Mechanical and Electrical Installation – EFB .....	150
Communication Set-up – EFB .....	151
Activate Drive Control Functions – EFB .....	153
Feedback from the Drive – EFB .....	157
Diagnostics – EFB .....	158
Modbus Protocol Technical Data .....	161
ABB Control Profiles Technical Data .....	169

## **Fieldbus Adapter**

Overview .....	181
Planning .....	183
Mechanical and Electrical Installation – FBA .....	184
Communication Set-up – FBA .....	185
Activate Drive Control Functions – FBA .....	185
Feedback from the Drive – FBA .....	188
Diagnostics – FBA .....	189
ABB Drives Profile Technical Data .....	191
Generic Profile Technical Data .....	199

## **Diagnostics**

Diagnostic Displays .....	201
Correcting Faults .....	202
Correcting Alarms .....	207

**Maintenance**

Maintenance Intervals .....	212
Heatsink .....	212
Main Fan Replacement .....	213
Internal Enclosure Fan Replacement .....	214
Capacitors .....	214
Control Panel .....	215

**Technical Data**

Ratings .....	216
Input Power Connections .....	220
Motor Connections .....	227
Brake Components .....	232
Control Connections .....	236
Efficiency .....	238
Cooling .....	238
Dimensions and Weights .....	241
Degrees of Protection .....	243
Ambient Conditions .....	244
Materials .....	245
Applicable Standards .....	245
Liability Limits .....	247

**Index**

# Installation

---

Study these installation instructions carefully before proceeding. **Failure to observe the warnings and instructions may cause a malfunction or personal hazard.**



**Warning! Before you begin read "Safety" on page 3.**

---

## Installation Flow Chart

The installation of the ACS550 adjustable speed AC drive follows the outline below. The steps must be carried out in the order shown. At the right of each step are references to the detailed information needed for the correct installation of the unit.

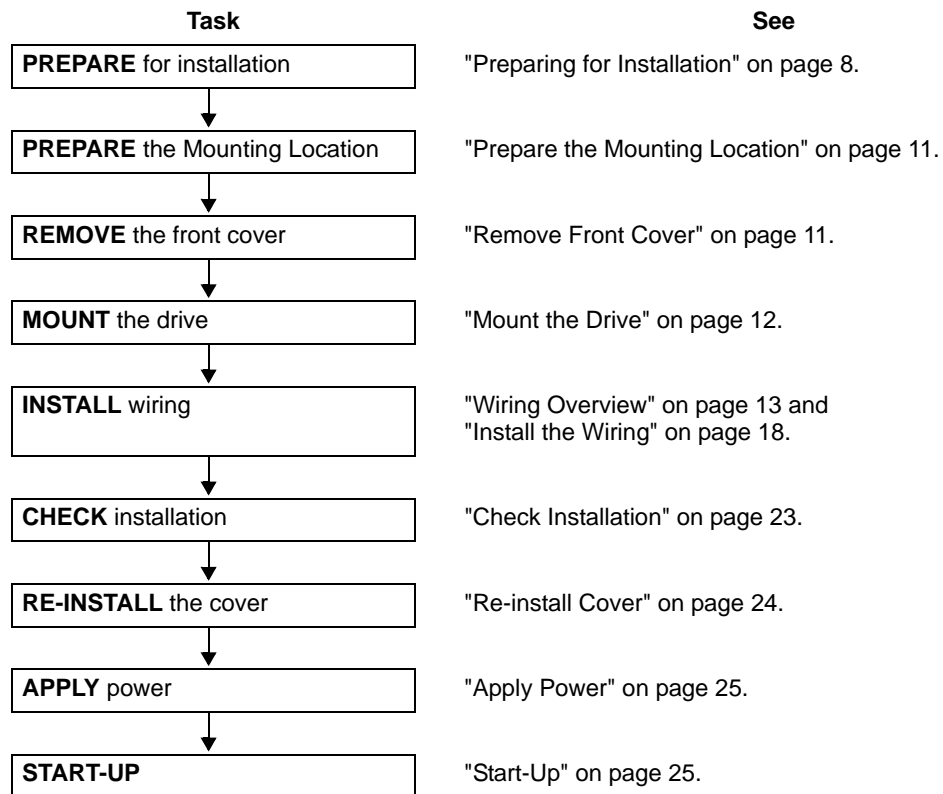

## Preparing for Installation

### Lifting the Drive

Lift the drive only by the metal chassis.

### Unpack the Drive

1. Unpack the drive.
2. Check for any damage and notify the shipper immediately if damaged components are found.
3. Check the contents against the order and the shipping label to verify that all parts have been received.



IP2040

### Drive Identification



#### Drive Labels

To determine the type of drive you are installing, refer to either:

- Serial number label attached on upper part of the chokeplate between the mounting holes.

<b>ACS550-01-08A8-4</b>		
<b>U<sub>1</sub></b>	3~ 380...480 V	 <b>Ser. no.*2030700001*</b>
<b>I<sub>2N</sub> / I<sub>2hd</sub></b>	8.8 A / 6.9 A	
<b>P<sub>N</sub>/P<sub>hd</sub></b>	4 / 3 kW	

- Type code label attached on the heat sink – on the right side of the unit cover.

<b>Input</b>	<b>U<sub>1</sub></b>	3~ 380...480 V	 <b>Ser. no.*2030700001*</b>
	<b>I<sub>1N</sub></b>	8.8 A	
	<b>f<sub>1</sub></b>	48...63 Hz	
<b>Output</b>	<b>U<sub>2</sub></b>	3~ 0...U <sub>1</sub> V	 <b>Ser. no.*2030700001*</b>
	<b>I<sub>2N</sub> / I<sub>2hd</sub></b>	8.8 A / 6.9 A	
	<b>f<sub>2</sub></b>	0...500 Hz	
<b>Motor</b>	<b>P<sub>N</sub>/P<sub>hd</sub></b>	4 / 3 kW	
<b>ACS550-01-08A8-4</b>			



### Type Code

Use the following chart to interpret the type code found on either label.

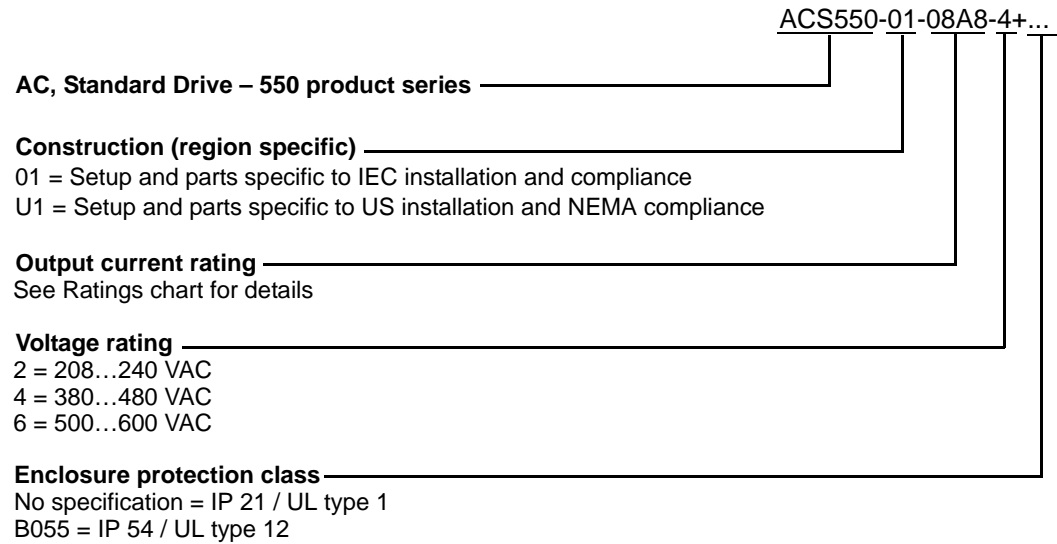

### Ratings and Frame Size

The chart in "Ratings" on page 216 lists technical specifications, and identifies the drive's frame size – significant, since some instructions in this document, vary, depending on the drive's frame size. To read the Ratings table, you need the "Output current rating" entry from the type code. Also, when using the Ratings table, note that the table is broken into sections based on the drive's "Voltage rating".

### Motor Compatibility

The motor, drive, and supply power must be compatible:

Motor Specification	Verify	Reference
Motor type	3-phase induction motor	–
Nominal current	Motor value is within this range: $0.2 \dots 2.0 * I_{2hd}$ ( $I_{2hd}$ = drive heavy duty current)	<ul style="list-style-type: none"> <li>Type code label on drive, entry for Output <math>I_{2hd}</math>, or</li> <li>Type code on drive and rating table in "Technical Data" on page 216.</li> </ul>
Nominal frequency	10...500 Hz	–
Voltage range	Motor is compatible with the ACS550 voltage range.	208...240 V (for ACS550-X1-XXXX-2) or 380...480 V (for ACS550-X1-XXXX-4) or 500...600 V (for ACS550-U1-XXXX-6)
Insulation	500...600 V drives: Either the motor complies with NEMA MG1 Part 31, or a du/dt filter is used between the motor and drive.	For ACS550-U1-XXXX-6

### Tools Required

To install the ACS550 you need the following:

- Screwdrivers (as appropriate for the mounting hardware used)

- Wire stripper
- Tape measure
- Drill
- For installations involving ACS550-U1, frame sizes R5 or R6 and IP 54 / UL type 12 enclosures: A punch for creating conduit mounting holes.
- For installations involving ACS550-U1, frame size R6: The appropriate crimping tool for power cable lugs. See "Power Terminal Considerations – R6 Frame Size".
- Mounting hardware: screws or nuts and bolts, four each. The type of hardware depends on the mounting surface and the frame size:

Frame Size	Mounting Hardware	
R1...R4	M5	#10
R5	M6	1/4 in
R6	M8	5/16 in

### Suitable Environment and Enclosure

Confirm that the site meets the environmental requirements. To prevent damage prior to installation, store and transport the drive according to the environmental requirements specified for storage and transportation. See "Ambient Conditions" on page 244.

Confirm that the enclosure is appropriate, based on the site contamination level:

- IP 21 / UL type 1 enclosure. The site must be free of airborne dust, corrosive gases or liquids, and conductive contaminants such as condensation, carbon dust, and metallic particles.
- IP 54 / UL type 12 enclosure. This enclosure provides protection from airborne dust and light sprays or splashing water from all directions.

### Suitable Mounting Location

Confirm that the mounting location meets the following constraints:

- The drive must be mounted vertically on a smooth, solid surface, and in a suitable environment as defined above.
- The minimum space requirements for the drive are the outside dimensions (see "Outside Dimensions" on page 242), plus air flow space around the unit (see "Cooling" on page 238).
- The distance between the motor and the drive is limited by the maximum motor cable length. See either "Motor Connection Specifications" on page 227, or "Motor Cable Requirements for CE & C-Tick Compliance" on page 228.
- The mounting site must support the drive's modest weight. See "Weight" on page 243.

## Installing the Drive



**Warning!** Before installing the ACS550, ensure the input power supply to the drive is off.

### Prepare the Mounting Location

The ACS550 should only be mounted where all of the requirements defined in "Preparing for Installation" on page 8 are met.

1. Mark the position of the mounting holes.
2. Drill the holes.

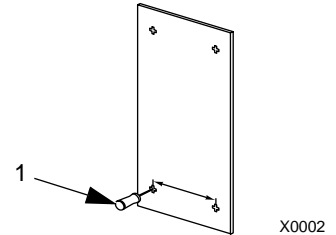

**Note!** Frame sizes R3 and R4 have four holes along the top. Use only two. If possible, use the two outside holes (to allow room to remove the fan for maintenance).

**Note!** ACS400 drives can be replaced using the original mounting holes. For R1 and R2 frame sizes, the mounting holes are identical. For R3 and R4 frame sizes, the inside mounting holes on the top of ACS550 drives match ACS400 mounts.

### Remove Front Cover

*IP 21 / UL Type 1*

1. Remove the control panel, if attached.
2. Loosen the captive screw at the top.
3. Pull near the top to remove the cover.

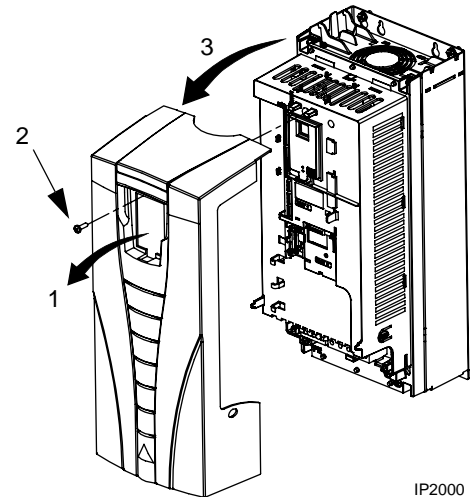

*IP 54 / UL Type 12*

1. If hood is present: Remove screws (2) holding hood in place.
2. If hood is present: Slide hood up and off of the cover.
3. Loosen the captive screws around the edge of the cover.
4. Remove the cover.

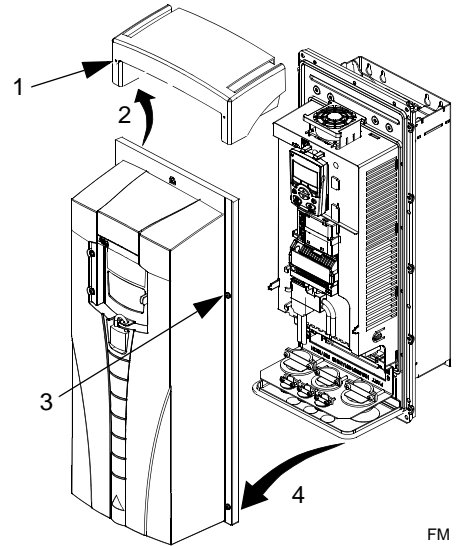
**Mount the Drive***IP 21 / UL Type 1*

1. Position the ACS550 onto the mounting screws or bolts and securely tighten in all four corners.

---

**Note!** Lift the ACS550 by its metal chassis.

---

2. Non-English speaking locations: Add a warning sticker in the appropriate language over the existing warning on the top of the module.

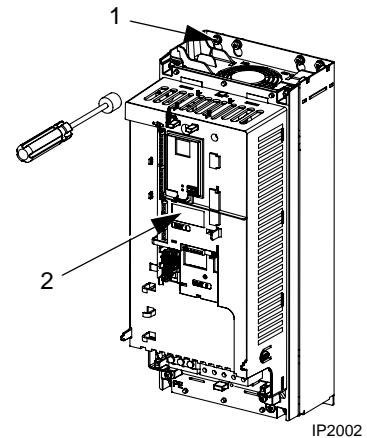
*IP 54 / UL Type 12*

For the IP54 / UL Type 12 enclosures, rubber plugs are required in the holes provided for access to the drive mounting slots.

1. As required for access, remove the rubber plugs. Push plugs out from the back of the drive.
2. R5 & R6: Align the sheet metal hood (not shown) in front of the drive's top mounting holes. (Attach as part of next step.)
3. Position the ACS550 onto the mounting screws or bolts and securely tighten in all four corners.

---

**Note!** Lift the ACS550 by its metal chassis.

---

4. Re-install the rubber plugs.
5. Non-English speaking locations: Add a warning sticker in the appropriate language over the existing warning on the top of the module.

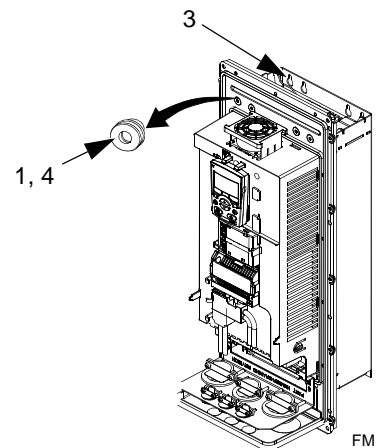

## Wiring Overview

### Conduit/Gland Kit

Wiring drives with the IP 21 / UL type 1 Enclosure requires a conduit/gland kit with the following items:

- Conduit/gland box
- Five (5) cable clamps (ACS550-01 only)
- Screws
- Cover

The kit is included with IP 21 / UL type 1 Enclosures.

### Wiring Requirements



**Warning! Ensure the motor is compatible for use with the ACS550. The ACS550 must be installed by a competent person in accordance with the considerations defined in "Preparing for Installation" on page 8. If in doubt, contact your local ABB sales or service office.**

As you install the wiring, observe the following:

- There are four sets of wiring instructions – one set for each combination of drive enclosure type (IP 21 / UL type and IP 54 / UL type 12), and wiring type (conduit or cable). Be sure to select the appropriate procedure.
- Determine electro-magnetic compliance (EMC) requirements per local codes. See "Motor Cable Requirements for CE & C-Tick Compliance" on page 228. In general:
  - Follow local codes for cable size.
  - Keep these four classes of wiring separated: input power wiring, motor wiring, control/communications wiring, and braking unit wiring.
- When installing input power and motor wiring, refer to the following, as appropriate:

Terminal	Description	Specifications and Notes
U1, V1, W1*	3-phase power supply input	"Input Power Connections" on page 220.
PE	Protective Ground	"Ground Connections" on page 223.
U2, V2, W2	Power output to motor	"Motor Connections" on page 227.

\* The ACS550 -x1-xxxx-2 (208...240V series) can be used with a single phase supply, if output current is derated by 50%. For single phase supply voltage, connect power at U1 and W1.

- To locate input power and motor connection terminals, see "Power Connection Diagrams" starting on page 15. For specifications on power terminals, see "Drive's Power Connection Terminals" on page 225.
- For frame sizes R1...R4 in unsymmetrically grounded networks, see "**Unsymmetrically Grounded Networks**" on page 224.
- For floating (or impedance grounded) networks, see "**Floating Networks**" on page 224.

- For frame size R6, see "Power Terminal Considerations – R6 Frame Size" on page 225 to install the appropriate cable lugs.
- For drives using braking (optional), refer to the following, as appropriate:

Frame Size	Terminal	Description	Braking Accessory
R1, R2	BRK+, BRK-	Braking resistor	Braking resistor. See "Brake Components" on page 232.
R3, R4, R5, R6	UDC+, UDC-	DC bus	Contact your ABB representative to order either: <ul style="list-style-type: none"> <li>• Braking unit or</li> <li>• Chopper and resistor</li> </ul>

- When installing control wiring, refer to the following, as appropriate:
  - "Control Terminals Table" on page 17.
  - "Control Connections" on page 236.
  - "Application Macros" on page 42.
  - "Complete Parameter Descriptions" on page 65.
  - "Embedded Fieldbus" on page 149.
  - "Fieldbus Adapter" on page 181.

Power Connection Diagrams

The following diagram shows the terminal layout for frame size R3, which, in general, applies to frame sizes R1...R6, except for the R5/R6 power and ground terminals.

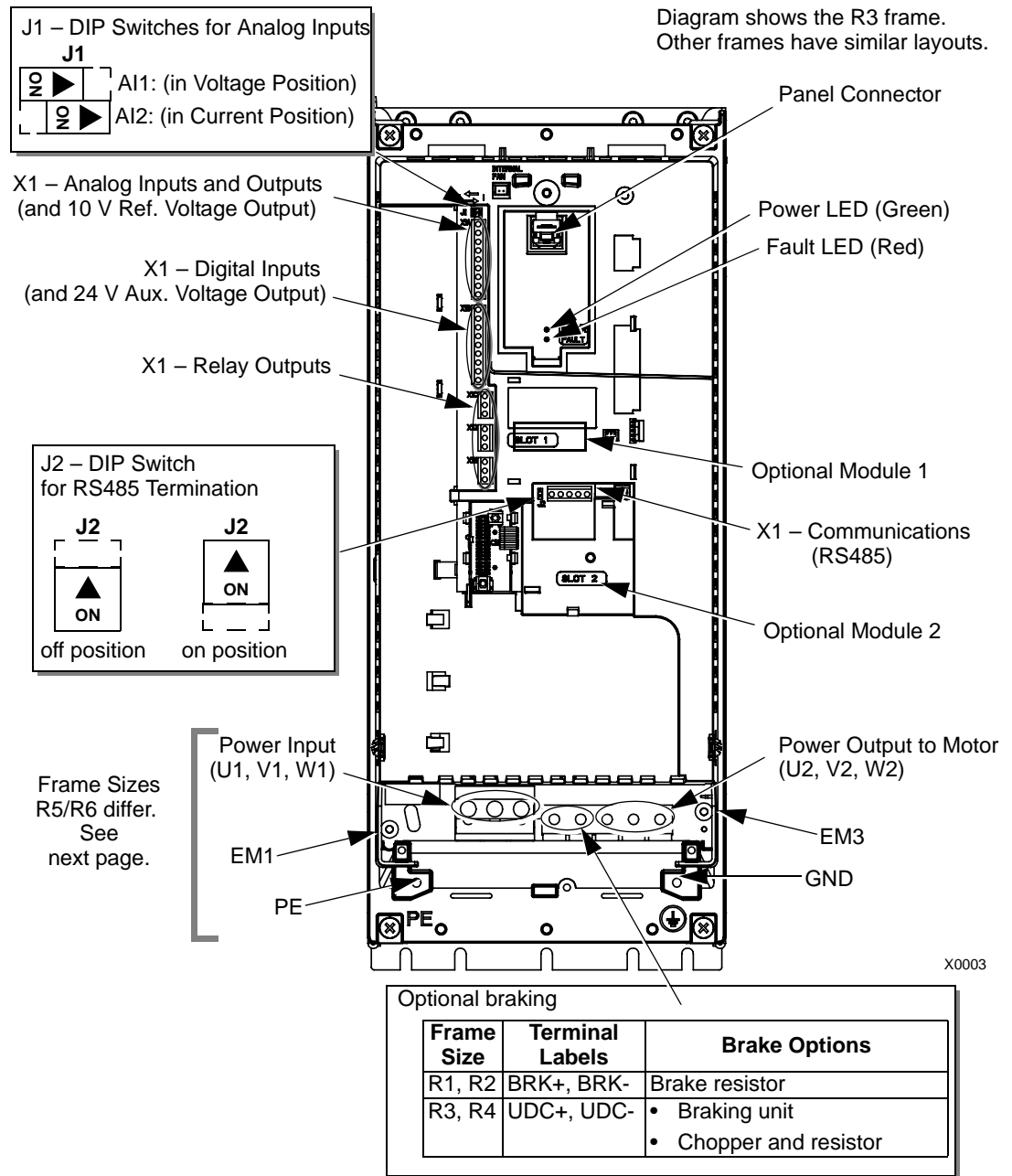

**Warning!** For floating, impedance grounded, or unsymmetrically grounded networks, disconnect the internal RFI filter by removing:

- On ACS550-01: screws EM1 and EM3.
  - On ACS550-U1: screw EM1 (drive is shipped with EM3 already removed).
- See "Floating Networks" on page 224.

The following diagram shows the power and ground terminal layout for frame sizes R5 and R6

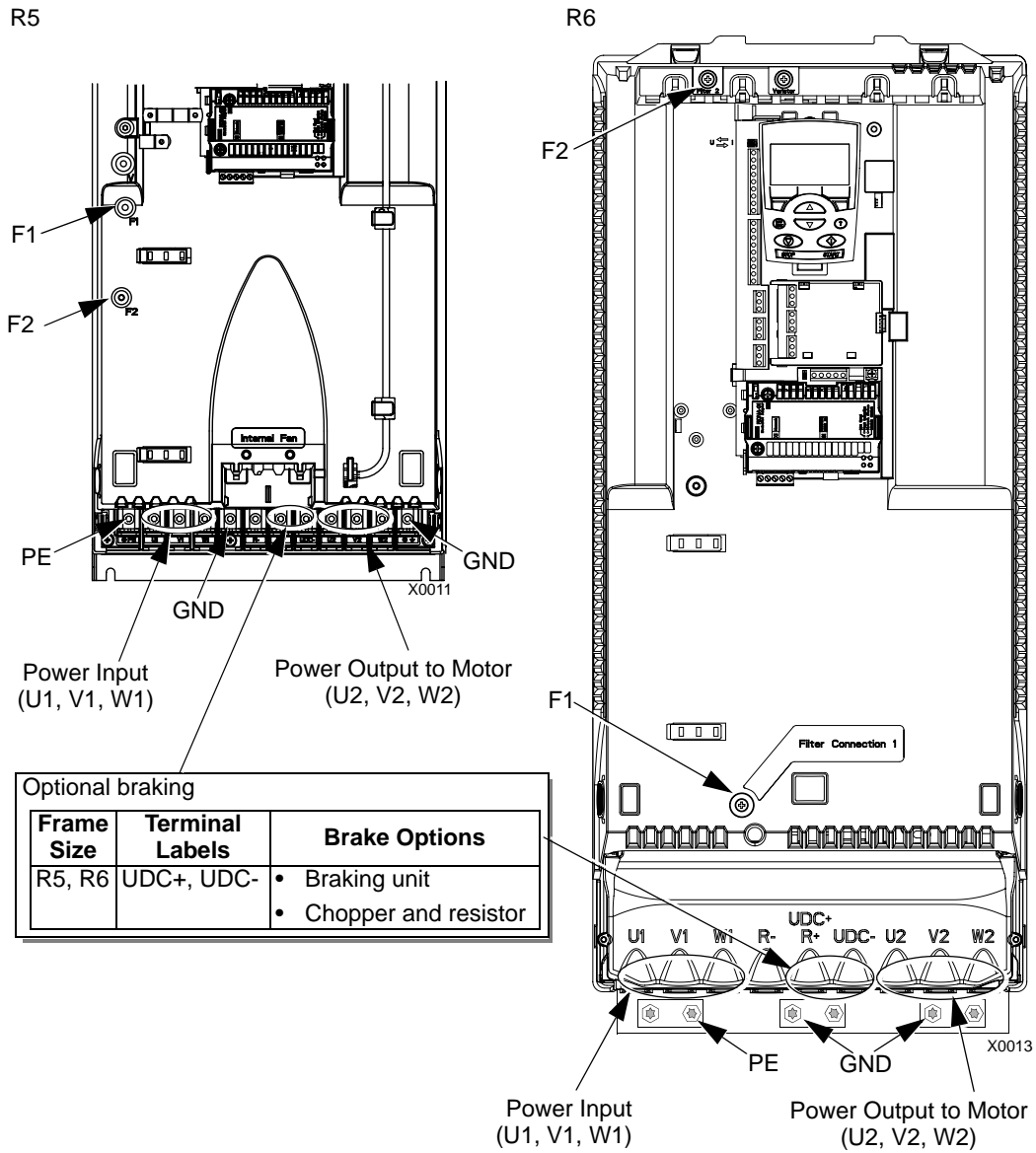





**Warning!** For floating, impedance grounded, or unsymmetrically grounded networks, disconnect the internal RFI filter by removing screws: F1 and F2. See "Floating Networks" on page 224.



## Control Terminals Table

The following provides information for connecting control wiring at X1 on the drive.

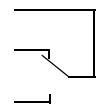
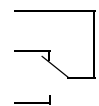
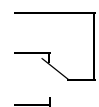
	X1	Hardware Description		
Analog I/O	1	SCR	Terminal for signal cable screen. (Connected internally to chassis ground.)	
	2	AI1	Analog input channel 1, programmable. Default <sup>2</sup> = frequency reference. Resolution 0.1%, accuracy $\pm 1\%$ .	
			J1:AI1 OFF: 0...10 V ( $R_i = 312 \text{ k}\Omega$ ) 	
			J1:AI1 ON: 0...20 mA ( $R_i = 100 \Omega$ ) 	
	3	AGND	Analog input circuit common (connected internally to chassis gnd. through 1 M $\Omega$ ).	
	4	+10 V	Potentiometer reference source: 10 V $\pm 2\%$ , max. 10 mA ( $1\text{k}\Omega \leq R \leq 10\text{k}\Omega$ ).	
	5	AI2	Analog input channel 2, programmable. Default <sup>2</sup> = not used. Resolution 0.1%, accuracy $\pm 1\%$ .	
			J1:AI2 OFF: 0...10 V ( $R_i = 312 \text{ k}\Omega$ ) 	
			J1:AI2 ON: 0...20 mA ( $R_i = 100 \Omega$ ) 	
	6	AGND	Analog input circuit common (connected internally to chassis gnd. through 1 M $\Omega$ ).	
7	AO1	Analog output, programmable. Default <sup>2</sup> = frequency. 0...20 mA (load < 500 $\Omega$ ).		
8	AO2	Analog output, programmable. Default <sup>2</sup> = current. 0...20 mA (load < 500 $\Omega$ ).		
9	AGND	Analog output circuit common (connected internally to chassis gnd. through 1 M $\Omega$ ).		
Digital Inputs <sup>1</sup>	10	+24V	Auxiliary voltage output 24 VDC / 250 mA (reference to GND), short circuit protected.	
	11	GND	Auxiliary voltage output common (connected internally as floating).	
	12	DCOM	Digital input common. To activate a digital input, there must be $\geq +10 \text{ V}$ (or $\leq -10 \text{ V}$ ) between that input and DCOM. The 24 V may be provided by the ACS550 (X1-10) or by an external 12...24 V source of either polarity.	
	13	DI1	Digital input 1, programmable. Default <sup>2</sup> = start/stop.	
	14	DI2	Digital input 2, programmable. Default <sup>2</sup> = fwd/rev.	
	15	DI3	Digital input 3, programmable. Default <sup>2</sup> = constant speed sel (code).	
	16	DI4	Digital input 4, programmable. Default <sup>2</sup> = constant speed sel (code).	
	17	DI5	Digital input 5, programmable. Default <sup>2</sup> = ramp pair selection (code).	
18	DI6	Digital input 6, programmable. Default <sup>2</sup> = not used.		
Relay Outputs	19	RO1C		Relay output 1, programmable. Default <sup>2</sup> = Ready Maximum: 250 VAC / 30 VDC, 2 A Minimum: 500 mW (12 V, 10 mA)
	20	RO1A		
	21	RO1B		
	22	RO2C		Relay output 2, programmable. Default <sup>2</sup> = Running Maximum: 250 VAC / 30 VDC, 2 A Minimum: 500 mW (12 V, 10 mA)
	23	RO2A		
	24	RO2B		
	25	RO3C		Relay output 3, programmable. Default <sup>2</sup> = Fault (-1) Maximum: 250 VAC / 30 VDC, 2 A Minimum: 500 mW (12 V, 10 mA)
	26	RO3A		
	27	RO3B		

<sup>1</sup> Digital input impedance 1.5 k $\Omega$ . Maximum voltage for digital inputs is 30 V.

<sup>2</sup> Default values depend on the macro used. Values specified are for the default macro. See "Application Macros" on page 42.

**Note!** Terminals 3, 6, and 9 are at the same potential.

**Note!** For safety reasons the fault relay signals a “fault” when the ACS550 is powered down.

You can wire the digital input terminals in either a PNP or NPN configuration.

PNP connection (source)

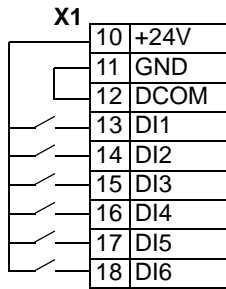

NPN connection (sink)

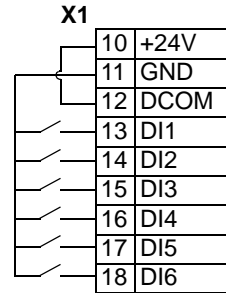

### Install the Wiring

#### Checking Motor and Motor Cable Insulation



**Warning! Check the motor and motor cable insulation before connecting the drive to input power. For this test, make sure that motor cables are NOT connected to the drive.**

1. Complete motor cable connections to the motor, but NOT to the drive output terminals (U2, V2, W2).
2. At the drive end of the motor cable, measure the insulation resistance between each motor cable phase and Protective Earth (PE): Apply a voltage of 1 kV DC and verify that resistance is greater than 1 Mohm.

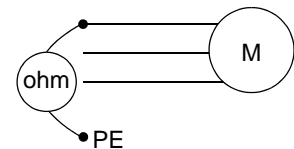

**Wiring IP 21 / UL type 1 Enclosure with Cables**

1. Open the appropriate knockouts in the conduit/gland box. (See "Conduit/Gland Kit" above.)
2. Install the cable clamps for the power/motor cables.
3. On the input power cable, strip the sheathing back far enough to route individual wires.
4. On the motor cable, strip the sheathing back far enough to expose the copper wire screen so that the screen can be twisted into a pig-tail. Keep the short pig-tail short to minimize noise radiation.
5. Route both cables through the clamps.
6. Strip and connect the power/motor wires, and the power ground wire to the drive terminals.

---

**Note!** For R5 frame size, the minimum power cable size is 25 mm<sup>2</sup> (4 AWG).  
For R6 frame size, refer to "Power Terminal Considerations – R6 Frame Size" on page 225.

---

7. Connect the pig-tail created from the motor cable screen.
8. Install conduit/gland box and tighten the cable clamps.
9. Install the cable clamp(s) for the control cable(s). (Power/motor cables and clamps not shown in figure.)
10. Strip control cable sheathing and twist the copper screen into a pig-tail.
11. Route control cable(s) through clamp(s) and tighten clamp(s).
12. Connect the ground screen pig-tail for digital and analog I/O cables at X1-1. (Ground only at drive end.)
13. Connect the ground screen pig-tail for RS485 cables at X1-28 or X1-32. (Ground only at drive end.)
14. Strip and connect the individual control wires to the drive terminals. See "Control Terminals Table" on page 17.
15. Install the conduit/gland box cover (1 screw).

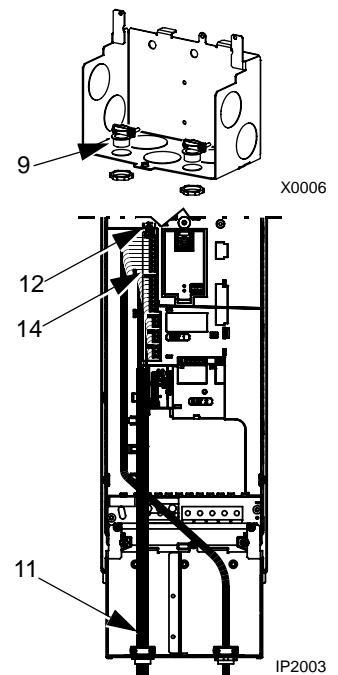
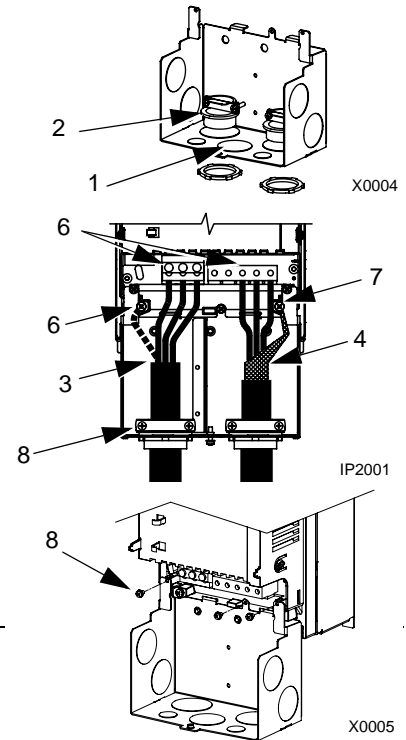

### Wiring IP 21 / UL Type 1 Enclosure with Conduit

1. Open the appropriate knockouts in the conduit/gland box. (See "Conduit/Gland Kit" above.)
2. Install thin-wall conduit clamps (not supplied).

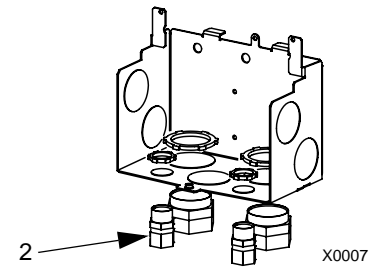

3. Install conduit/gland box.
4. Connect conduit runs to box.

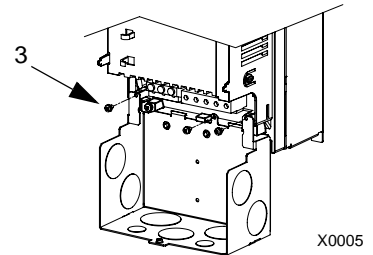

5. Route input power and motor wiring through conduits (must be separate conduit runs).
6. Strip wires.
7. Connect power, motor, and ground wires to the drive terminals.

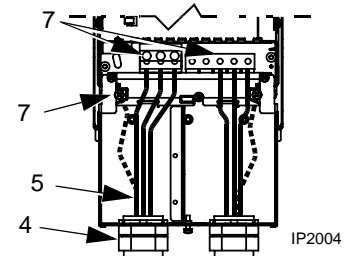

**Note!** For R5 frame size, the minimum power cable size is 25 mm<sup>2</sup> (4 AWG).

For R6 frame size, refer to "Power Terminal Considerations – R6 Frame Size" on page 225.

8. Route the control cable through the conduit (must be separate from input power and motor conduit runs).
9. Strip the control cable sheathing and twist the copper screen into a pig-tail.
10. Connect the ground screen pig-tail for digital and analog I/O cables at X1-1. (Ground only at drive end.)
11. Connect the ground screen pig-tail for RS485 cables at X1-28 or X1-32. (Ground only at drive end.)
12. Strip and connect the individual control wires to the drive terminals. See "Control Terminals Table" on page 17.
13. Install the conduit/gland box cover (1 screw).

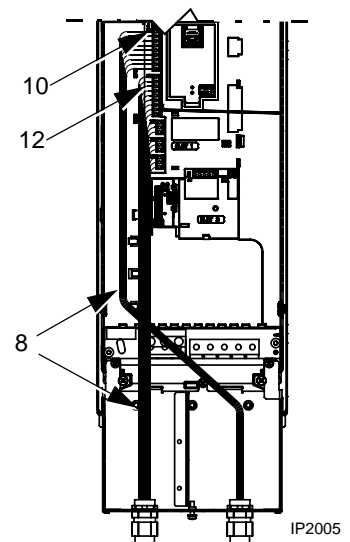

### Wiring **IP 54** / UL Type 12 Enclosure with **Cables**

1. Cut the cable seals as needed for the power, motor, and control cables. (The cable seals are cone-shaped, rubber seals on the bottom of the drive.)

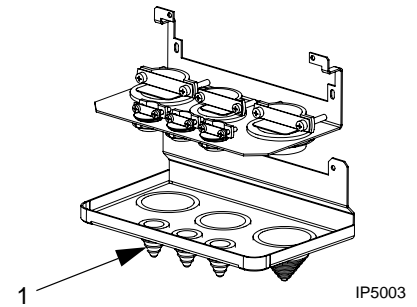

2. On the input power cable, strip the sheathing back far enough to route individual wires.
3. On the motor cable, strip the sheathing back far enough to expose the copper wire screen so that the screen can be twisted into a pig-tail. Keep the short pig-tail short to minimize noise radiation.
4. Route both cables through the clamps and tighten the clamps.
5. Strip and connect the power/motor wires, and the power ground wire to the drive terminals.

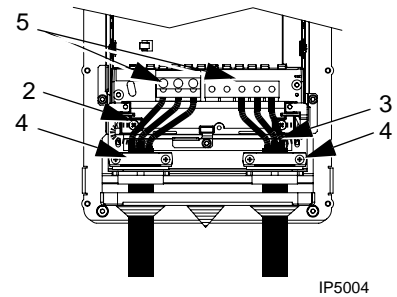



---

**Note!** For R5 frame size, the minimum power cable size is 25 mm<sup>2</sup> (4 AWG). For R6 frame size, refer to "Power Terminal Considerations – R6 Frame Size" on page 225.

---

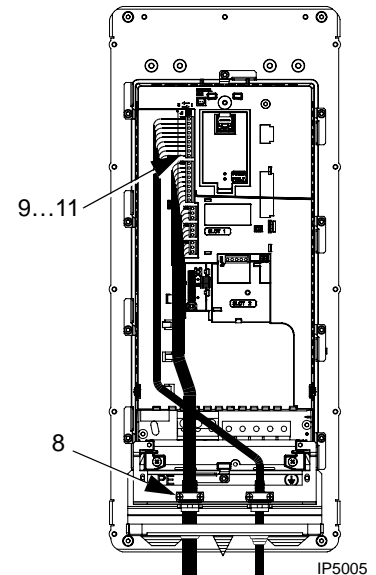
6. Connect the pig-tail created from the motor cable screen.
7. Strip control cable sheathing and twist the copper screen into a pig-tail.
8. Route control cable(s) through clamp(s) and tighten clamp(s).
9. Connect the ground screen pig-tail for digital and analog I/O cables at X1-1. (Ground only at drive end.)
10. Connect the ground screen pig-tail for RS485 cables at X1-28 or X1-32. (Ground only at drive end.)
11. Strip and connect the individual control wires to the drive terminals. See "Control Terminals Table" on page 17.



### Wiring IP 54 / UL Type 12 Enclosure with Conduit

1. Depends on Frame Size:
  - R1...R4: Remove and discard the cable seals where conduit will be installed. (The cable seals are cone-shaped, rubber seals on the bottom of the drive.)
  - R5 and R6: Use punch to create holes for conduit connections as needed.
2. For each conduit run, install water tight conduit connectors (not supplied).
3. Route the power wiring through the conduit.
4. Route the motor wiring through the conduit.
5. Strip the wires.
6. Connect the power, motor, and ground wires to the drive terminals.

---

**Note!** For R5 frame size, the minimum power cable size is 25 mm<sup>2</sup> (4 AWG).

For R6 frame size, refer to "Power Terminal Considerations – R6 Frame Size" on page 225.

---

7. Route the control cable through the conduit.
8. Strip the control cable sheathing and twist the copper screen into a pig-tail.
9. Connect the ground screen pig-tail for digital and analog I/O cables at X1-1. (Ground only at drive end.)
10. Connect the ground screen pig-tail for RS485 cables at X1-28 or X1-32. (Ground only at drive end.)
11. Strip and connect the individual control wires to the drive terminals. See "Control Terminals Table" on page 17.

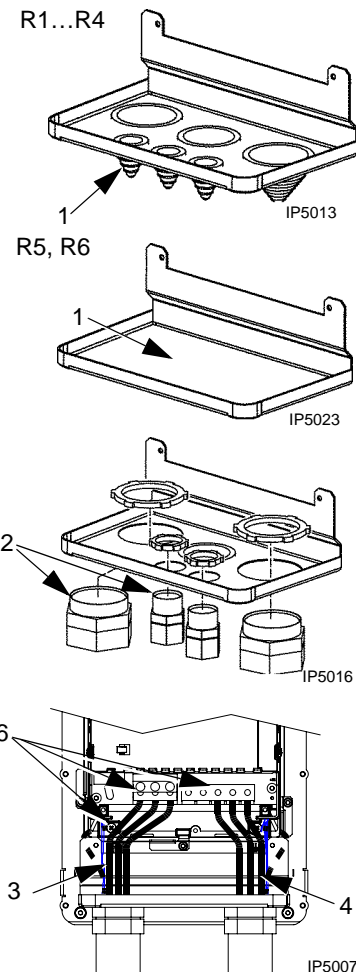

## Check Installation

Before applying power, perform the following checks.

✓	Check
	Installation environment conforms to the drive's specifications for ambient conditions.
	The drive is mounted securely.
	Space around the drive meets the drive's specifications for cooling.
	The motor and driven equipment are ready for start.
	For floating networks: The internal RFI filter is disconnected (screws EM1 & EM3 or F1 & F2).
	The drive is properly grounded.
	The input power (mains) voltage matches the drive nominal input voltage.
	The input power (mains) connections at U1, V1, and W1 are connected and tightened as specified.
	The input power (mains) fuses are installed.
	The motor connections at U2, V2, and W2 are connected and tightened as specified.
	The motor cable is routed away from other cables.
	NO power factor compensation capacitors are in the motor cable.
	The control connections are connected and tightened as specified.
	NO tools or foreign objects (such as drill shavings) are inside the drive.
	NO alternate power source for the motor (such as a bypass connection) is connected – no voltage is applied to the output of the drive.

## Re-install Cover

### IP 21 / UL Type 1

1. Align the cover and slide it on.
2. Tighten the captive screw.
3. Re-install the control panel.

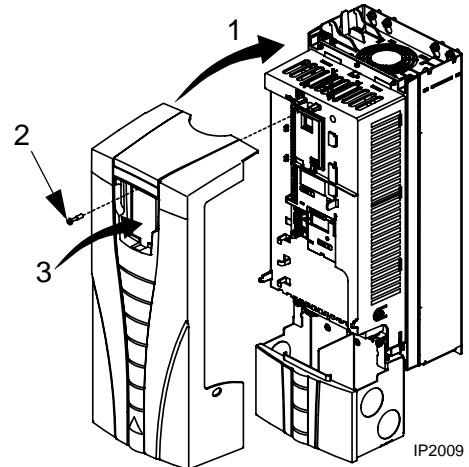

### IP 54 / UL Type 12

1. Align the cover and slide it on.
2. Tighten the captive screws around the edge of the cover.
3. R1...R4: Slide the hood down over the top of the cover.
4. R1...R4: Install the two screws that attach the hood.
5. Install the control panel.

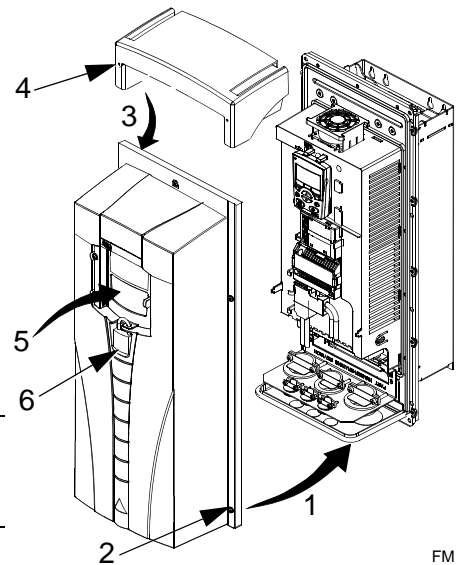

---

**Note!** The control panel window must be closed to comply with IP 54/UL type 12.

---

6. Optional: Add a lock (not supplied) to secure the control panel window.



## Apply Power

Always re-install the front cover before turning power on.

---



**Warning! The ACS550 will start up automatically at power up, if the external run command is on.**

---

1. Apply input power.

When power is applied to the ACS550, the green LED comes on.

---

**Note!** Before increasing motor speed, check that the motor is running in the desired direction.

---

## Start-Up

The ACS550 has default parameter settings that are sufficient for many situations. However, review the following situations. Perform the associated procedures as appropriate.

### *Motor Data*

The motor data on the ratings plate may differ from the defaults in the ACS550. The drive provides more precise control and better thermal protection if you enter the rating plate data.

1. Gather the following from the motor ratings plate:
  - Voltage
  - Nominal motor current
  - Nominal frequency
  - Nominal speed
  - Nominal power
2. Edit parameters 9905...9909 to the correct values.
  - Assistant Control Panel: The Start-up Assistant walks you through this data entry (see page 31).
  - Basic Control Panel: Refer to "Parameters Mode" on page 39, for parameter editing instructions.

### *Macros*

---

**Note!** Selecting the appropriate macro should be part of the original system design, since the wiring installed in "Control Terminals Table" on page 17 depends on the macro used.

---

1. Review the macro descriptions in "Application Macros" on page 42. Use the macro that best fits system needs.

2. Edit parameter 9902 to select the appropriate macro.
  - Assistant Control Panel – Use either of the following:
    - Use the Start-up Assistant, which displays the macro selection immediately after motor parameter setup.
    - Refer to "Parameters Mode" on page 31, for parameter editing instructions.
  - Basic Control Panel: Refer to "Parameters Mode" on page 39, for parameter editing instructions.

#### *Tuning – Parameters*

The system can benefit from one or more of the ACS550 special features, and/or fine tuning.

1. Review the parameter descriptions in "Complete Parameter Descriptions" starting on page 65. Enable options and fine tune parameter values as appropriate for the system.
2. Edit parameters as appropriate.

#### *Fault and Alarm Adjustments*

The ACS550 can detect a wide variety of potential system problems. For example, initial system operation may generate faults or alarms that indicate set-up problems.

1. Faults and alarms are reported on the control panel with a number. Note the number reported.
2. Review the description provided for the reported fault/alarm:
  - Use the fault and alarm listings on pages 202 and 208 respectively (or page 210 for the Basic Control Panel's alarm listing), or
  - Press the help key (Assistant Control Panel only) while fault or alarm is displayed.
3. Adjust the system or parameters as appropriate.

# Start-Up

---

Start-up configures the drive. This process sets parameters that define how the drive operates and communicates. Depending on the control and communication requirements, the start-up process may require any or all of the following:

- The Start-up Assistant (requires the Assistant Control Panel) steps you through the default configuration. The Start-up Assistant runs automatically at the first power up, or can be accessed at any time using the main menu.
- Application macros can be selected to define common, alternate system configurations, using the default settings. See "Application Macros" on page 42.
- Additional refinements can be made using the control panel to manually select and set individual parameters. See "Complete Parameter Descriptions" on page 65.

## Control Panels

Use a control panel to control the ACS550, to read status data, and to adjust parameters. The ACS550 works with either of two different control panel types:

- Assistant Control Panel – This panel (described below) includes pre-programmed assistants to automate the most common parameter setups.
- Basic control panel – This panel (described in a later section) provides basic tools for manual entry of parameter values.

## Assistant Control Panel

### Features

The ACS550 Assistant Control Panel features:

- Alphanumeric control panel with a LCD display
- Language selection for the display
- Drive connection that can be made or detached at any time
- Start-up Assistant to ease drive commissioning
- Copy function – Parameters can be copied to the Control Panel memory for later transfer to other drives, or for backup of a particular system.
- Context sensitive help

## Controls/Display Overview

The following table summarizes the button functions and displays on the Assistant Control Panel.

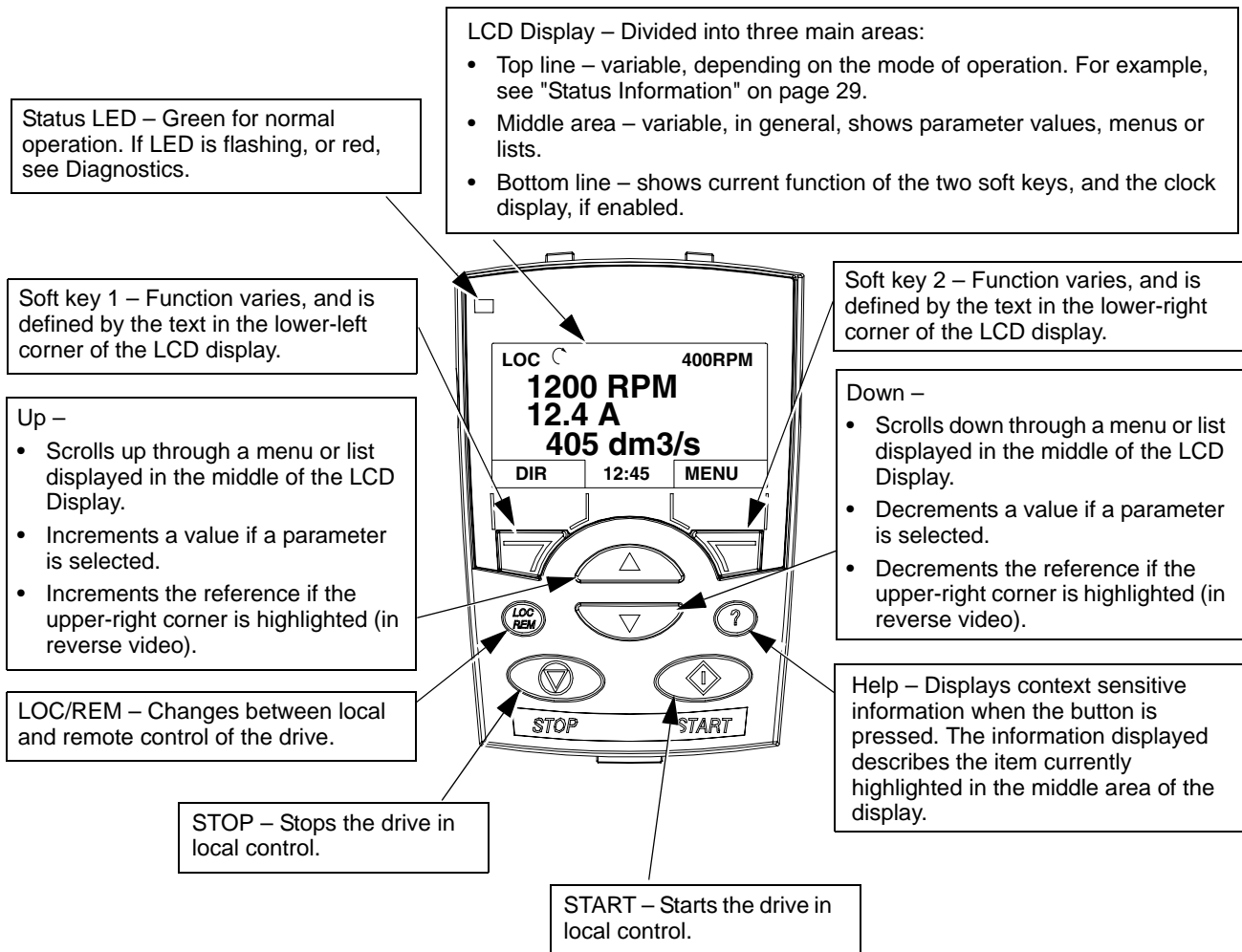

## General Display Features

### Soft Key Functions

The soft key functions are defined by text displayed just above each key.

### Display Contrast

To adjust display contrast, simultaneously press the MENU key and UP or DOWN, as appropriate.

### Output Mode

Use the Output mode to read information on the drive's status and to operate the drive. To reach the Output mode, press EXIT until the LCD display shows status information as described below.

Status Information

**Top.** The top line of the LCD display shows the basic status information of the drive.

- LOC – indicates that the drive control is local, that is, from the control panel.
- REM – indicates that the drive control is remote, such as the basic I/O (X1) or fieldbus.
- ↻ – indicates the drive and motor rotation status as follows:

Control Panel Display	Significance
Rotating arrow (clockwise or counter clockwise)	<ul style="list-style-type: none"> <li>• Drive is running and at setpoint</li> <li>• Shaft direction is forward ↻ or reverse ↻</li> </ul>
Rotating dotted blinking arrow	Drive is running but not at setpoint.
Stationary dotted arrow	Start command is present, but motor is not running. E.g. start enable is missing.

- Upper right – shows the active reference.

**Middle.** Using parameter Group 34, the middle of the LCD display can be configured to display:

- Up to three parameter values.

- By default, the display shows three parameters. The particular parameters depend on the value of parameter 9904 MOTOR CTRL MODE. For example, if 9904 = 1, the display shows parameters 0102 (SPEED), 0104 (CURRENT), 0105 (TORQUE).

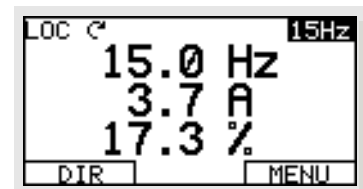

- Use parameters 3401, 3408, and 3415 to select the parameters (from Group 01) to display. Entering “parameter” 0100 results in no parameter displayed. For example, if 3401 = 0100 and 3415 = 0100, then only the parameter specified by 3408 appears in the Control Panel display.
- You can also scale each parameter in the display, for example, to convert the motor speed to a display of conveyor speed. Parameters 3402...3405 scale the parameter specified by 3401, parameters 3409...3412 scale the parameter specified by 3408, etc.

- A bar graph rather than any of the parameter values.

- Enable bar graph displays using parameters 3404, 3411 and 3418.

**Bottom.** The bottom of the LCD display shows:

- Lower corners – show the functions currently assigned to the two soft keys.
- Lower middle – displays the current time (if configured to show the time).

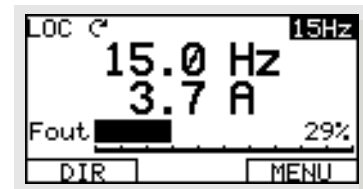

Operating the Drive

**LOC/REM** – The very first time the drive is powered up, it is in the remote control (REM) mode, and is controlled from the Control Terminal Block X1.

To switch to local control (LOC) and control the drive using the control panel, press and hold the  button until first, LOCAL CONTROL, or later, LOCAL, KEEP RUN, is displayed:

- Release the button while LOCAL CONTROL is displayed to set the panel reference to the current external reference. The drive stops.
- Release the button when LOCAL, KEEP RUN is displayed, to copy the current run/stop status and the reference from the user I/O.

To switch back to remote control (REM) press and hold the  button until REMOTE CONTROL is displayed.

**Start/Stop** – To start and stop the drive press the START and STOP buttons.

**Shaft direction** – To change the shaft direction press DIR (parameter 1003 must be set to 3 (REQUEST)).

**Reference** – To modify the reference (only possible if the display in the upper right corner is highlighted) press the UP or DOWN buttons (the reference changes immediately).

The reference can be modified when in local control (LOC), and can be parameterized (using Group 11: Reference Select) to also allow modification when in remote control (REM).

---

**Note!** The Start/Stop, Shaft direction and Reference functions are only valid in local control (LOC) mode.

---

## Other Modes

Besides the Output mode, the Assistant Control Panel has:

- Other operating modes that are available through the main menu.
- A fault mode that is triggered by faults. The fault mode includes a diagnostic assistant mode.
- An alarm mode that is triggered by drive alarms.

### *Access to Main Menu and the Other Modes*

To reach the main menu:

1. Press EXIT, as necessary, to step back through the menus or lists associated with a particular mode. Continue until you are back to the Output mode.
2. Press MENU from the Output mode.

At this point, the middle of the display is a listing of the other modes, and the top-right text says "Main menu"

3. Press UP/DOWN to scroll to the desired mode.
4. Press ENTER to enter the mode that is highlighted.



The following sections describe each of the other modes.

## Parameters Mode

Use the Parameters mode to view and edit parameter values:

1. Select PARAMETERS in the Main Menu.
2. Press UP/DOWN to highlight the appropriate parameter group, then press SEL.
3. Press UP/DOWN to highlight the appropriate parameter in a group.

**NOTE!** The current parameter value appears below the highlighted parameter.

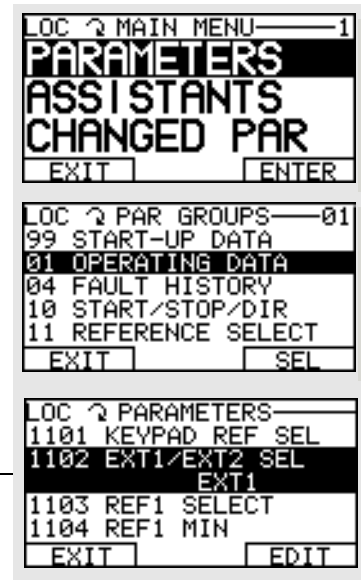

4. Press EDIT.
5. Press UP/DOWN to step to the desired parameter value.

**Note!** To view the parameter default value: In the set mode, press UP/DOWN simultaneously.

6. Press SAVE to store the modified value or press CANCEL to leave the set mode. Any modifications not saved are cancelled.
7. Press EXIT to return to the listing of parameter groups, and again to return to the main menu.

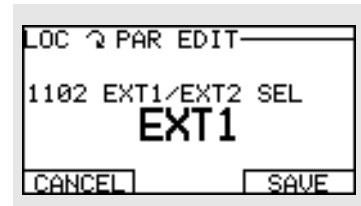

## Start-up Assistant Mode

When the drive is first powered up, the Start-up Assistant guides you through the setup of a few basic parameters. For example, at the first start, the drive automatically suggests entering the first task, Language Select.

The Start-up Assistant is divided into tasks. You may activate the tasks one after the other, as the Start-up Assistant suggests, or independently. (You are not required to use the assistant, you may use instead, the parameter mode to set the drive parameters.)

The order of the tasks presented by the Start-up Assistant depends on your entries. The task list in the following table is typical.

Task name	Description
Language Select	Selects the language used in control panel displays.
Motor Set-up	Enters motor data and motor identification.
Application	Selects an application macro.
Option Modules	Activates optional modules, if any, mounted on the drive.
Speed Control EXT1	<ul style="list-style-type: none"> <li>• Selects the source for the speed reference.</li> <li>• Sets the reference limits.</li> <li>• Sets the speed (or frequency) limits.</li> <li>• Sets acceleration and deceleration times.</li> <li>• Sets up the brake chopper if activated.</li> </ul>
Speed Control EXT2	<ul style="list-style-type: none"> <li>• Sets the source for the speed reference.</li> <li>• Sets the reference limits.</li> </ul>
Torque Control	<ul style="list-style-type: none"> <li>• Selects the source for the torque reference.</li> <li>• Sets the reference limits.</li> <li>• Sets the torque ramp up and ramp down times.</li> </ul>
PID Control	<ul style="list-style-type: none"> <li>• Selects the source for the process reference.</li> <li>• Sets the reference limits.</li> <li>• Sets the speed (reference) limits.</li> <li>• Sets the source and limits for the process actual value.</li> </ul>
Start/Stop Control	<ul style="list-style-type: none"> <li>• Selects either EXT1 or EXT2.</li> <li>• Defines the direction control.</li> <li>• Defines the start and stop modes.</li> <li>• Selects the use of Run Enable signal.</li> </ul>
Protections	Sets the torque and current limits.
Output Signals	<p>Selects the signals indicated through the relay outputs RO1, RO2, RO3 and optional relay output's (if installed).</p> <p>Selects the signals indicated through the analog outputs AO1 and AO2. Sets the minimum, maximum, scaling and inversion values.</p>

1. Select ASSISTANTS in the Main Menu.
2. Press UP/DOWN to select START-UP ASSISTANT.

---

**Note!** Rather than the Start-up Assistant, you can select Assistants for individual tasks, such as Output Signals.

---

3. Make entries or selections as appropriate.
4. Press SAVE to save settings. Each individual parameter setting is valid immediately after pressing SAVE.



### Changed Parameters Mode

Use the Changed Parameters mode to view (and edit) a listing of all parameters that have been changed from macro default values.

Procedure:

1. Select CHANGED PAR in the Main Menu.  
The display lists all changed parameters.
2. Press ENTER.
3. Press UP/DOWN to select a changed parameter.  
As each parameter is highlighted, the parameter value appears.
4. Press EDIT to edit the parameter value.
5. Press UP/DOWN to select a new value / edit the parameter value. (Pressing both keys at the same time sets a parameter to its default value.)
6. Press SAVE to save the new parameter value. (If the new value is the default value, the parameter will no longer appear on the Changed Parameters listing.)

### Fault Logger Mode

Use the Fault Logger Mode to see drive fault history, fault state details and help for the faults.

1. Select FAULT LOGGER in the Main Menu.
2. Press ENTER to see the latest faults (up to 10 faults, maximum).
3. Press DETAIL to see details for the selected fault.
  - Details are available for the three latest faults.
4. Press DIAG to see the help description for the fault. See "Diagnostics" section.

---

**Note!** If a power off occurs, only the three latest faults will remain (with details only for the most recent fault).

---

### Clock Set Mode

Use the Clock Set mode to:

- Enable/disable the clock function.
  - Set date and time.
  - Select display format.
1. Select CLOCK SET in the Main Menu.
  2. Press UP/DOWN to step to the desired option.
  3. Press EDIT.
  4. Press UP/DOWN to select the desired setting.
  5. Press SAVE to save setting.

## Par Backup Mode

The Assistant Control Panel can store a full set of drive parameters.

The Par Backup mode has these functions:

- **Upload to Panel** – Copies all parameters from the drive to the Control Panel. This includes user sets of parameters (if defined) and internal parameters such as those created by the Motor Id Run. The Control Panel memory is non-volatile and does not depend on the panel's battery.
- **Download Full Set** – Restores the full parameter set from the Control Panel to the drive. Use this option to restore a drive, or to configure identical drives. This download does not include user sets of parameters.

**Note!** Download Full Set writes all parameters to the drive, including motor parameters. Only use this function to restore a drive, or to transfer parameters to systems that are identical to the original system.

- **Download Application** – Copies a partial parameter set from the Control Panel to a drive. The partial set does not include internal motor parameters, parameters 9905...9909, 1605, 1607, 5201, nor any Group 51 and 53 parameters. Use this option to transfer parameters to systems that use similar configurations – the drive and motor sizes do not need to be the same.
- **Download User Set 1** - Copies USER S1 parameters (user sets are saved using parameter 9902 APPLIC MACRO) from the Control Panel to the drive.
- **Download User Set 2** - Copies USER S2 parameters from the Control Panel to the drive.

The general procedure for parameter backup operations is:

1. Select PAR BACKUP in the Main Menu.
2. Press UP/DOWN to step to the desired option.
3. Press ENTER.

The parameter set is transferred as directed. During the transfer, the display shows the transfer status as a percent of completion.

4. Press EXIT to step back to the Output mode.

### *Handling Inexact Downloads*

In some situations, an exact copy of the download is not appropriate for the target drive. Some examples:

- A download to an old drive specifies parameters/values that are not available on the old drive.
- A download (from an old drive) to a new drive does not have definitions for the new parameters – parameters that did not originally exist.
- A download can include an illegal value for the target drive, e.g. a backup from a small drive can have a switching frequency of 12 kHz whereas a big drive can only handle 8 kHz.

As a default, the control panel handles these situations by:

- Discarding parameters/values not available on the target drive.
- Using parameter default values when the download provides no values or invalid values.
- Providing a Differences List – A listing of the type and number of items that the target cannot accept exactly as specified.

LOC  DIFFERENCES ----	
VALUES UNDER MIN	3
VALUES OVER MAX	2
INVALID VALUES	1
EXTRA PARS	5
MISSING VALUES	7
READY	SEL

You can either accept the default edits by pressing READY, or view and edit each item as follows:

1. Highlight an item type in the Differences List (left screen below) and press SEL to see the details for the selected type (right screen below).

LOC  DIFFERENCES ----	
VALUES UNDER MIN	3
VALUES OVER MAX	2
INVALID VALUES	1
EXTRA PARS	5
MISSING VALUES	7
READY	SEL

→

LOC  INVALID VAL	
9902 APLIC MACRO	
2606*SWITCHING FREQ	
12 kHz	
8 kHz	
3401*DISP 1 SEL	
EXIT	EDIT

In the above-right “details” screen:

- The first item that requires editing is automatically highlighted and includes details: In general, the first item listed in the details is the value defined by the backup file. The second item listed is the “default edit.”
  - For tracking purposes, an asterisk initially appears by each item. As edits are made, the asterisks disappear.
2. In the illustrated example, the backup specifies a switching frequency of 12 kHz, but the target drive is limited to 8 kHz.
  3. Press EDIT to edit the parameter. The display is the target drive’s standard edit screen for the selected parameter.
  4. Highlight the desired value for the target drive.
  5. Press SAVE to save setting.
  6. Press EXIT to step back to the differences view and continue for each remaining exception.
  7. When your editing is complete, press READY in the Differences List and then select “Yes, save parameters.”

### Download Failures

In some situations, the drive may be unable to accept a download. In those cases, the control panel display is: “Parameter download failed” plus one of the following causes:

- Set not found – You are attempting to download a data set that was not defined in the backup. The remedy is to manually define the set, or upload the set from a drive that has the desired set definitions.
- Par lock – The remedy is to unlock the parameter set (parameter 1602).
- Incompat drive/model – The remedy is to perform backups only between drives of the same type (ACS/industrial or ACH/HVAC) and the same model (all ACS550).
- Too many differences – The remedy is to manually define a new set, or upload the set from a drive that more closely resembles the target drive.

### **I/O Settings Mode**

Use the I/O Setting mode to check (and edit) the setting at any I/O terminal.

1. Select I/O SETTINGS in the Main Menu.
2. Press UP/DOWN to step to the desired I/O group, for example, digital inputs.
3. Press ENTER.
4. Press UP/DOWN to step to a particular item, for example DI1.  
After a brief pause, the displays shows the current setting for the selection.
5. Press EDIT.
6. Press UP/DOWN to select a new setting.
7. Press SAVE to save.

## Basic Control Panel

### Features

The Basic Control Panel features:

- Numeric control panel with a LCD display.
- Drive connection that can be made or detached at any time
- Copy function – Parameters can be copied to the Control Panel memory for later transfer to other drives, or for backup of a particular system.

### Controls/Display Overview

The following table summarizes the button functions and displays on the Basic Control Panel.

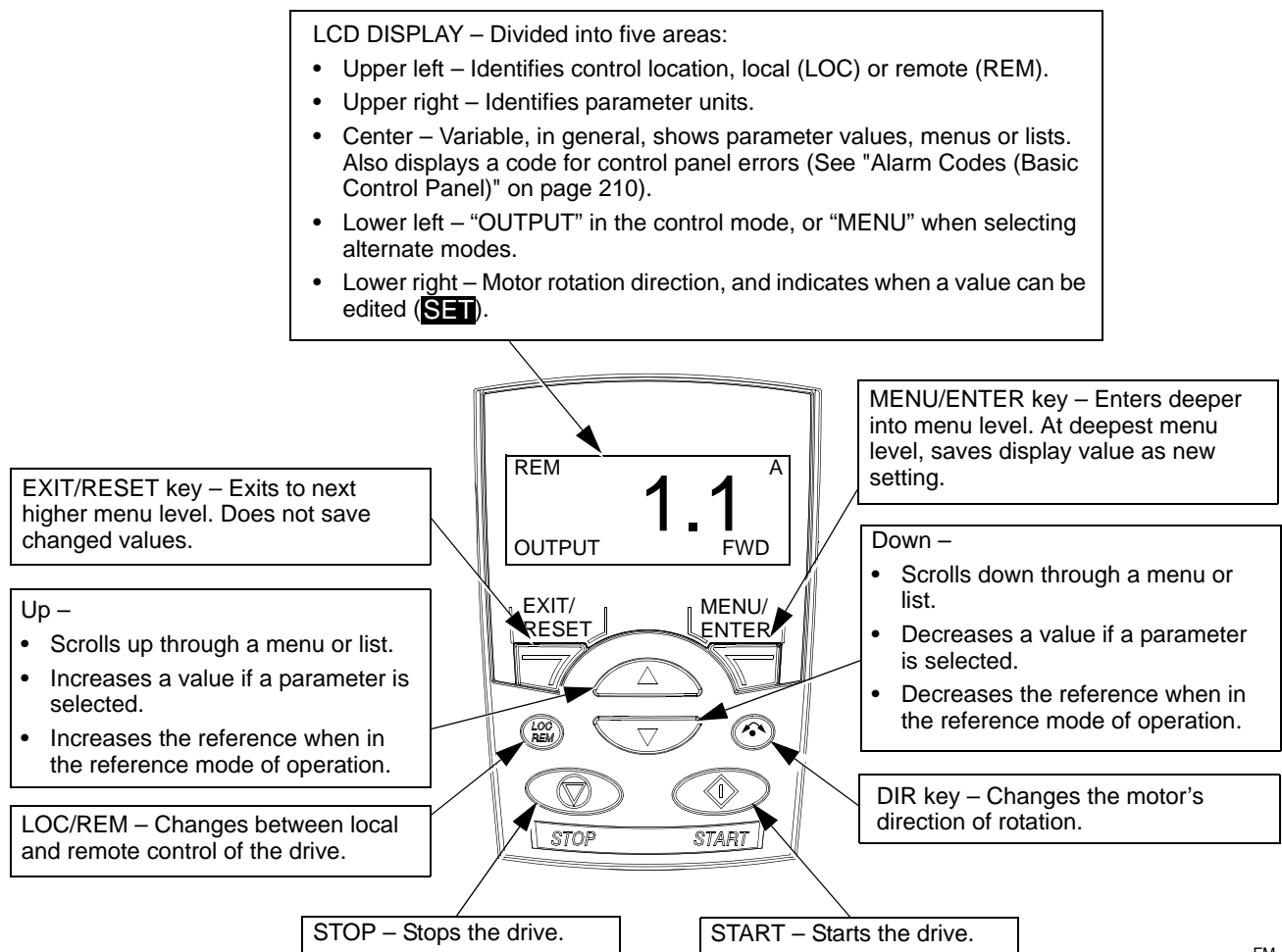

FM

### Output Mode

Use the Output mode to read information on the drive's status and to operate the drive. To reach the Output mode, press EXIT/RESET until the display shows status information as described below.

### Status Information

When the Basic Control Panel is in the Output mode, the display:

- Top-left shows the control location:
  - LOC – indicates that the drive control is local, that is, from the control panel.
  - REM – indicates that the drive control is remote, such as the basic I/O (X1) or fieldbus.
- The center of the display provides one Group 01 parameter value at a time, and makes up to three parameter values available (press UP or DOWN to scroll through available parameters).
  - By default, the display can scroll through three parameters. The particular default display parameters depend on the value of parameter 9904 MOTOR CTRL MODE. For example, if 9904 = 1, the default display scrolls through parameters 0102 (SPEED), 0104 (CURRENT) and 0105 (TORQUE).
  - To change the defaults, use parameters 3401, 3408, and 3415 to select the parameters (from Group 01) in the scroll list. Enter value 0100 to disable any of the three items in the scroll list. For example, if 3401 = 0100 and 3415 = 0100, then scrolling is disabled and only the parameter specified by 3408 appears in the Control Panel display.
  - You can also scale each item in the scroll list, for example, to convert motor speed to a display of conveyor speed. Parameters 3402...3405 scale the parameter specified by 3401, parameters 3409...3412 scale the parameter specified by 3408, etc.
- Top-right shows the units for the parameter value.
- Bottom-left shows OUTPUT.
- Bottom-right shows the motor direction of rotation. Text display (FWD or REV) is:
  - Steady when the motor is up to speed
  - Flashing slowly when the motor is stopped.
  - Flashing quickly when the motor is accelerating.



### Operating the Drive

**LOC/REM** – The very first time the drive is powered up, it is in the remote control (REM) mode, and is controlled from the Control Terminal Block X1.

To switch to local control (LOC) and control the drive using the control panel, press



. If you:

- Press and release (the display flashes “LOC”), then: the drive stops. Use the Reference Mode to set the local control reference.
- Press and hold for about 2 seconds (release when the display changes from “LoC” to “LoC r”), then the drive continues as before. The drive copies the current remote values for run/stop status and the reference, and uses them as the initial local control commands.

To switch back to remote control (REM) press .

**Start/Stop** – To start and stop the drive press the START and STOP buttons.

**Shaft direction** – To change the shaft direction press DIR ↕ (parameter 1003 must be set to 3 (REQUEST)).

**Reference** – See "Reference Mode" below.

### Reference Mode

Use the Reference Mode to set the speed or frequency reference. Normally this reference control is only possible when the drive is under Local (LOC) control. However, the drive can be set up (using Group 11: Reference Select) to also allow reference modification when the drive is under remote (REM) control.

1. Starting from the Output mode, press MENU/ENTER.

The display shows one of the following alternate modes:

- reF (Reference)
- PAr (Parameter)
- CoPY (Copy)

2. Use UP or DOWN arrow key to step through to the "reF" (Reference Mode).
3. Press MENU/ENTER.

The display shows the current reference value with **SET** under the value.

---

**Note!** Normally, reference adjustment is only possible here when under LOC control, but settings in Group 11, do allow reference adjustments under REM control. The **SET** display indicates when reference adjustment is possible at the control panel.

---

4. Use UP or DOWN arrow key to step to the desired reference value.
5. Press EXIT/RESET to step back to the Output mode.

### Parameters Mode

Use the Parameter Mode to set parameter values.

1. Starting from the Output mode, press MENU/ENTER.

The display shows one of the following alternate modes:

- reF (Reference)
- PAr (Parameter)
- CoPY (Copy)

2. Use UP or DOWN arrow key to step through to the "PAr" (Parameter Mode).
3. Press MENU/ENTER.

The display shows one of the parameter groups:

- "01"
- ...
- "99"

4. Use UP or DOWN arrow key to step through to the desired group, for example "03".
5. Press MENU/ENTER.

The display shows one of the parameters in the selected parameter group. For example, "0301".

6. Use UP or DOWN arrow key to step through to the desired parameter.
7. Press MENU/ENTER, either:

- Press and hold for about 2 seconds or
- Press the key twice in quick succession

The display shows the value of the selected parameter with **SET** under the value.

---

**Note!** Briefly pressing the MENU/ENTER key displays the parameter's current value for about 2 seconds. During this display, pressing the MENU/ENTER key again also enables **SET**.

---

8. Use UP or DOWN arrow key to step to the desired parameter value.

---

**Note!** In **SET**, pressing the UP and DOWN arrow keys simultaneously displays the default parameter value.

---

9. In **SET**, press MENU/ENTER to save the parameter value being displayed.

---

**Note!** If, instead, you press EXIT/RESET the original, or last saved, parameter value is the active value.

---

10. Press EXIT/RESET to step back to the Output mode.

### Par Backup Mode

The Basic Control Panel can store a full set of drive parameters. If two sets of parameters are defined, both are copied and transferred when using this feature.

The Par Backup mode has three functions:

- uL (Upload) – Copies all parameters from the drive to the Control Panel. This includes a second set of parameters (if defined) and internal parameters such as those created by the Motor Id Run. The Control Panel memory is non-volatile.
- rE A (Restore All) – Restores the full parameter set(s) from the Control Panel to the drive. Use this option to restore a drive, or to configure identical drives.

---

**Note!** The Restore All function writes all parameters to the drive, including motor parameters. Only use this function to restore a drive, or to transfer parameters to systems that are identical to the original system.

---



- dL P (Download Partial) – Copies a partial parameter set from the Control Panel to a drive. The partial set does not include internal motor parameters, parameters 9905...9909, 1605, 1607, 5201, nor any Group 51 and Group 53 parameters. Use this option to transfer parameters to systems that use similar configurations – the drive and motor sizes do not need to be the same.
  - dL u1 (Download User Set 1) – Copies USER S1 parameters (user sets are saved using parameter 9902 APPLIC MACRO) from the Control Panel to the drive.
  - dl u2 (Download User Set 2) – Copies USER S2 parameters from the Control Panel to the drive.
1. Starting from the Output mode, press MENU/ENTER.  
The display shows one of the following alternate modes:
    - reF (Reference)
    - PAr (Parameter)
    - CoPY (Copy)
  2. Use UP or DOWN arrow key to step through to the “CoPY” (Copy) Mode.
  3. Press MENU/ENTER.  
The display shows one of the following copy options:
    - uL (Upload)
    - rE A (Restore All)
    - dL P (Download Partial)
  4. Use UP or DOWN arrow key to step to the desired option.
  5. Press MENU/ENTER.  
The parameter set is transferred as directed. During the transfer, the display shows the transfer status as a percent of completion.
  6. Press EXIT/RESET to step back to the Output mode.

#### *Handling Inexact Downloads*

In some situations, an exact copy of the download is not appropriate for the target drive. The Basic control panel automatically handles these situations by:

- Discarding parameters/values not available on the target drive.
- Using parameter default values when the download provides no values or invalid values.

#### **Alarm Codes**

The Basic Control Panel indicates Control Panel alarms with a code of the form A5xxx. See "Alarm Codes (Basic Control Panel)" on page 210 for a list of the alarm codes and descriptions.

## Application Macros

Macros change a group of parameters to new, predefined values. Use macros to minimize the need for manual editing of parameters. Selecting a macro sets all other parameters to their default values, except:

- Group 99: Start-up Data parameters (except parameter 9904)
- The PARAMETER LOCK 1602
- The PARAM SAVE 1607
- The COMM FAULT FUNC 3018 and COMM FAULT TIME 3019
- The COMM PROT SEL 9802
- Groups 50...53 parameters
- Group 29 Maintenance triggers

After selecting a macro, additional parameter changes can be made manually using the control panel.

Application macros are enabled by setting the value for parameter 9902 APPLIC MACRO. By default, 1, ABB Standard, is the enabled macro.

The following sections describe each of the application macros and provide a connection example for each macro.

The last section below, "Macro Default Values for Parameters" lists the parameters that the macros change, and the default values established by each macro.

### Application Macro: ABB Standard (Default)

This macro provides a general purpose, 2-wire I/O configuration, with three (3) constant speeds. This is the default macro. Parameter values are the default values defined in the "Complete Parameter List for ACS550" on page 53.

Connection example:

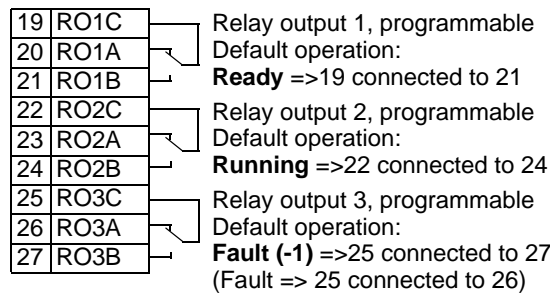
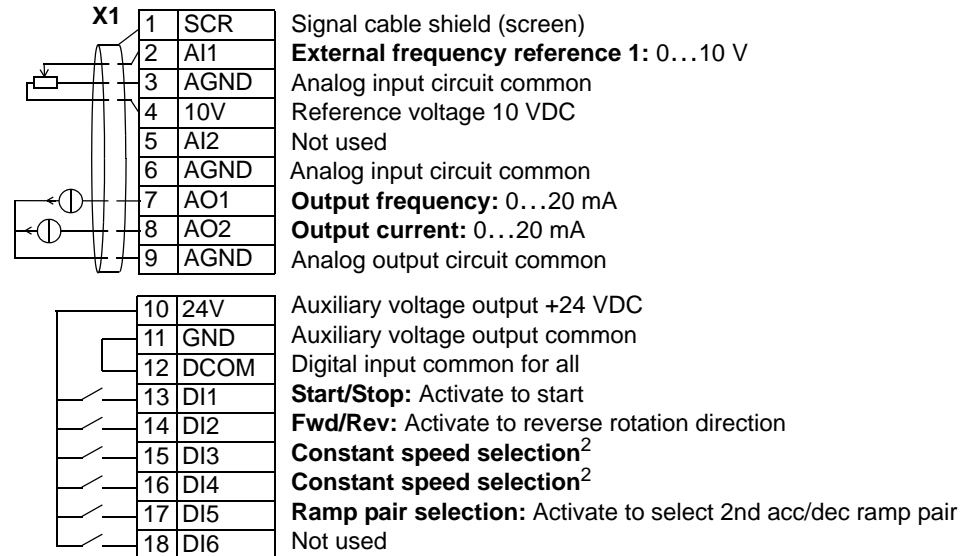

**Note 1.** The external reference is used as a speed reference, if a vector mode is selected,

**Note 2.** Code:  
0 = open, 1 = connected

DI3	DI4	Output
0	0	Reference through AI1
1	0	CONSTANT SPEED 1 (1202)
0	1	CONSTANT SPEED 2 (1203)
1	1	CONSTANT SPEED 3 (1204)

#### Input signals

- Analog reference (AI1)
- Start, stop and direction (DI1,2)
- Constant speed selection (DI3,4)
- Ramp pair (1 of 2) selection (DI5)

#### Output signals

- Analog output AO1: Frequency
- Analog output AO2: Current
- Relay output 1: Ready
- Relay output 2: Running
- Relay output 3: Fault (-1)

#### Jumper Setting

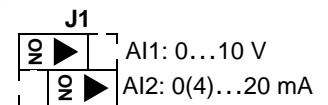

### Application Macro: 3-wire

This macro is used when the drive is controlled using momentary push-buttons, and provides three (3) constant speeds. To enable, set the value of parameter 9902 to 2 (3-WIRE).

**Note!** When the stop input (DI2) is deactivated (no input), the control panel start/stop buttons are disabled.

Connection example:

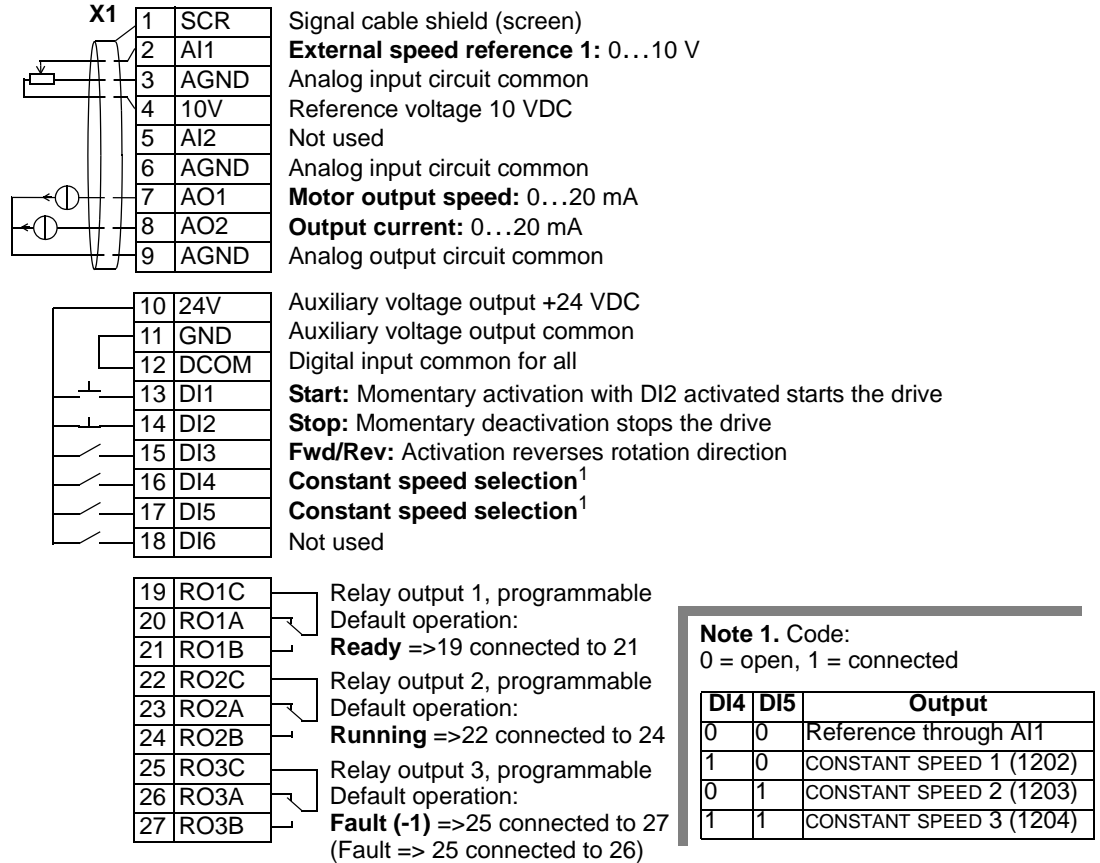

#### Input signals

- Analog reference (AI1)
- Start, stop and direction (DI1,2,3)
- Constant speed selection (DI4,5)

#### Output signals

- Analog output AO1: Speed
- Analog output AO2: Current
- Relay output 1: Ready
- Relay output 2: Running
- Relay output 3: Fault (-1)

#### Jumper Setting

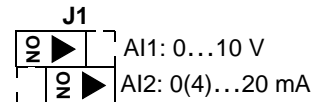

### Application Macro: Alternate

This macro provides an I/O configuration adopted to a sequence of DI control signals used when alternating the rotation direction of the drive. To enable, set the value of parameter 9902 to 3 (ALTERNATE).

Connection example:

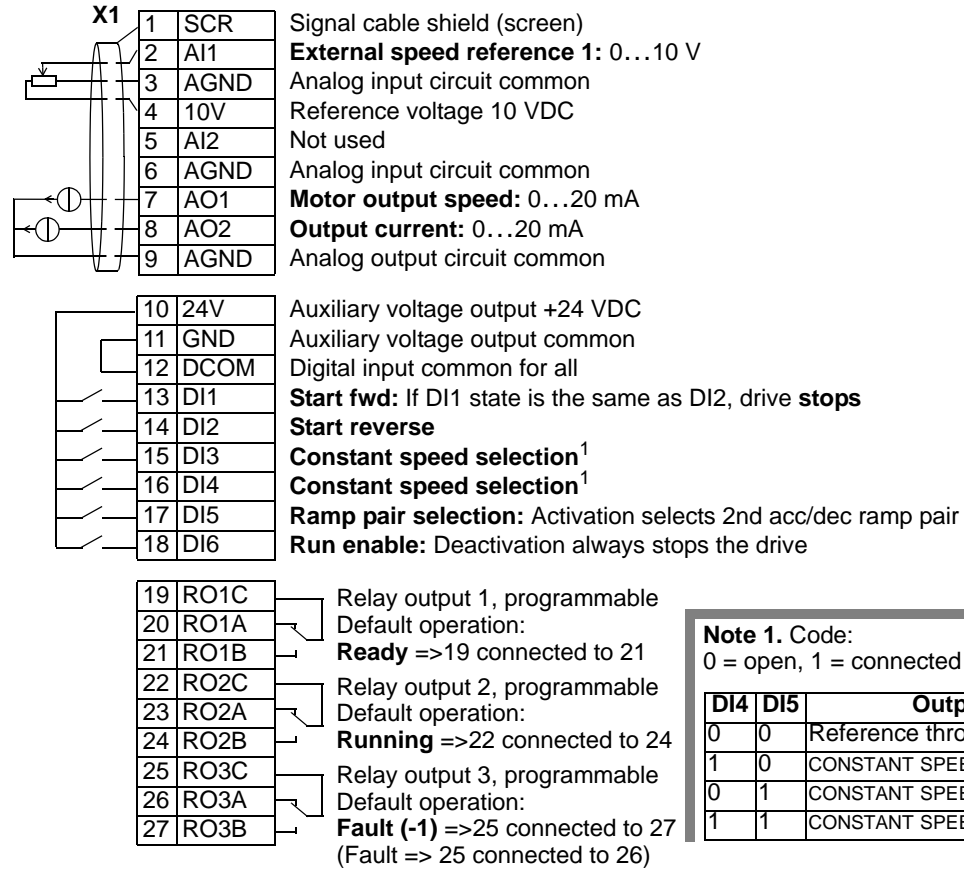

**Note 1. Code:**  
0 = open, 1 = connected

DI4	DI5	Output
0	0	Reference through AI1
1	0	CONSTANT SPEED 1 (1202)
0	1	CONSTANT SPEED 2 (1203)
1	1	CONSTANT SPEED 3 (1204)

#### Input signals

- Analog reference (AI1)
- Start, stop and direction (DI1,2)
- Constant speed selection (DI3,4)
- Ramp pair 1/2 selection (DI5)
- Run enable (DI6)

#### Output signals

- Analog output AO1: Speed
- Analog output AO2: Current
- Relay output 1: Ready
- Relay output 2: Running
- Relay output 3: Fault (-1)

#### Jumper Setting

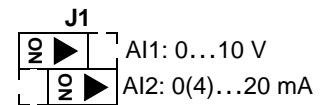

### Application Macro: Motor Potentiometer

This macro provides a cost-effective interface for PLCs that vary the speed of the drive using only digital signals. To enable, set the value of parameter 9902 to 4 (MOTOR POT).

Connection example:

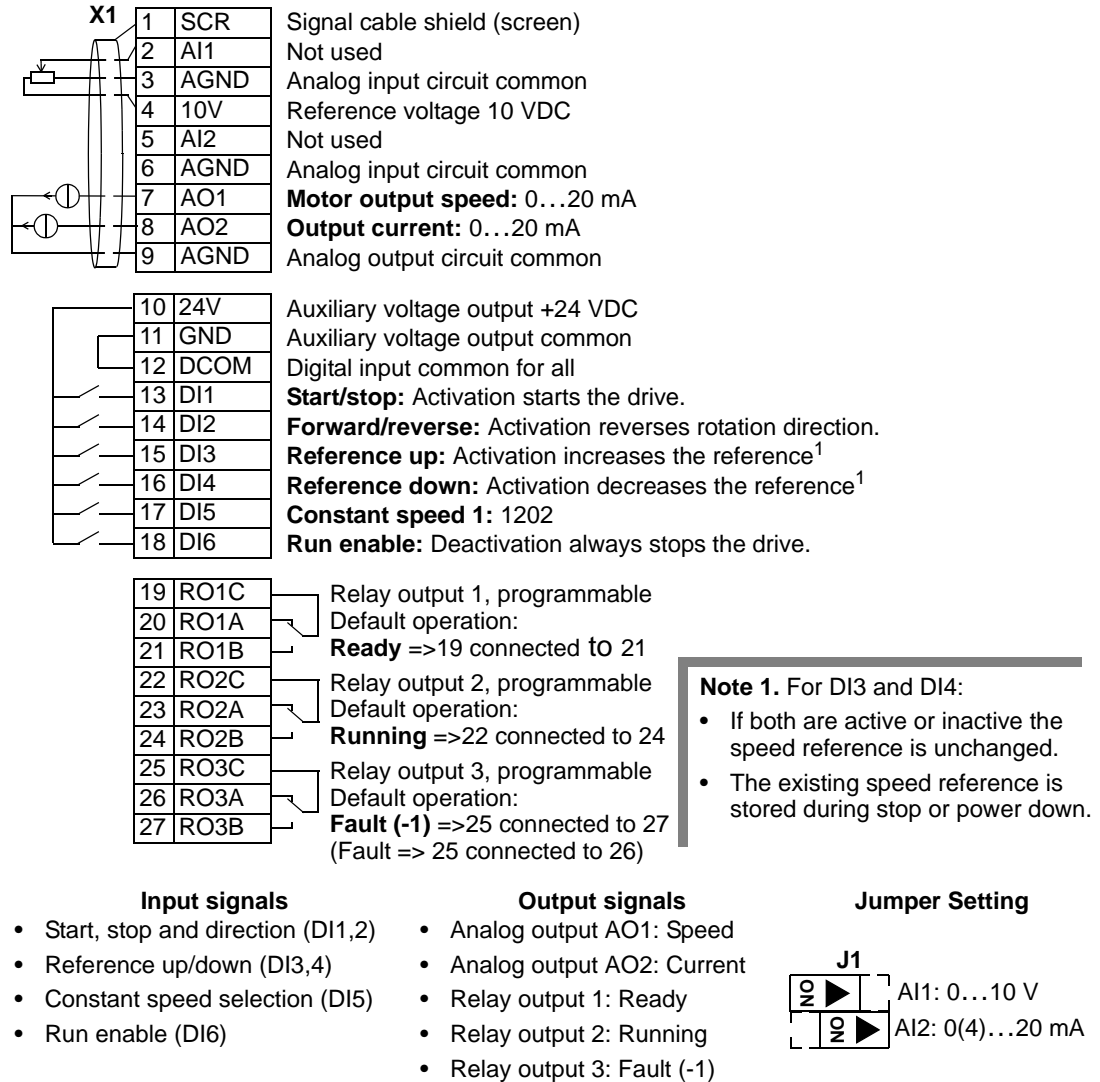

### Application macro: Hand-Auto

This macro provides an I/O configuration that is typically used in HVAC applications. To enable, set the value of parameter 9902 to 5 (HAND/AUTO).

**Note!** Parameter 2108 START INHIBIT must remain in the default setting, 0 (OFF).

Connection example:

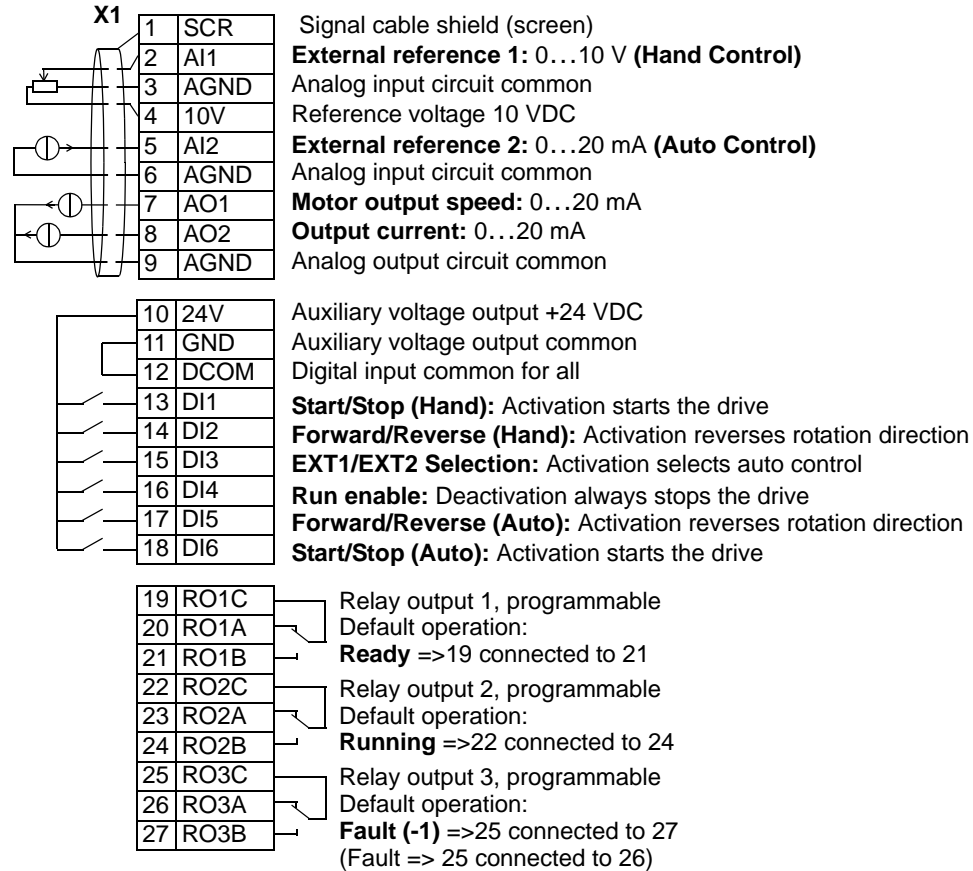

#### Input signals

- Two analog references (AI1, 2)
- Start/stop – hand/auto (DI1, 6)
- Direction – hand/auto (DI2, 5)
- Control location selection (DI3)
- Run enable (DI4)

#### Output signals

- Analog output AO1: Speed
- Analog output AO2: Current
- Relay output 1: Ready
- Relay output 2: Running
- Relay output 3: Fault (-1)

#### Jumper Setting

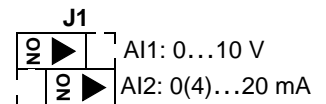

### Application Macro: PID Control

This macro provides parameter settings for closed-loop control systems such as pressure control, flow control, etc. To enable, set the value of parameter 9902 to 6 (PID CTRL).

**Note!** Parameter 2108 START INHIBIT must remain in the default setting, 0 (OFF).

Connection example:

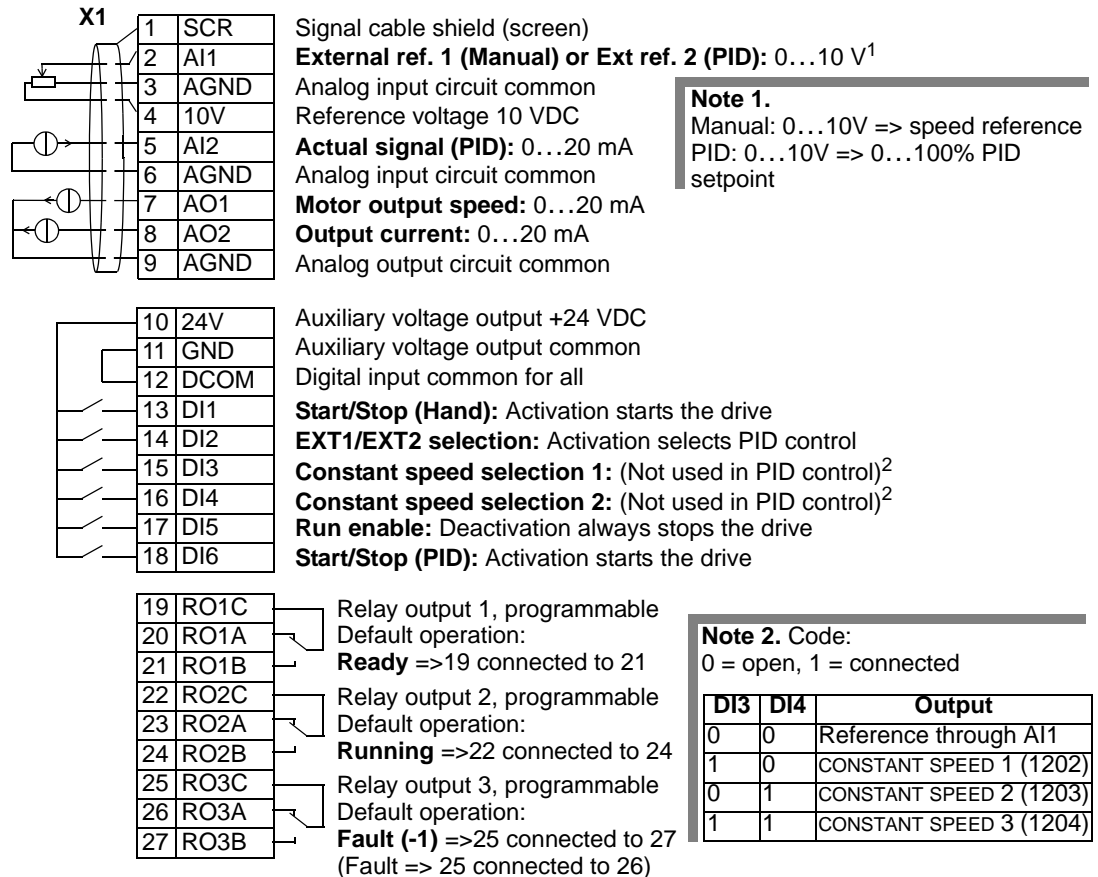

**Input signals**

- Analog reference (AI1)
- Actual value (AI2)
- Start/stop – hand/PID (DI1, 6)
- EXT1/EXT2 selection (DI2)
- Constant speed selection (DI3, 4)
- Run enable (DI5)

**Output signals**

- Analog output AO1: Speed
- Analog output AO2: Current
- Relay output 1: Ready
- Relay output 2: Running
- Relay output 3: Fault (-1)

**Jumper Setting**

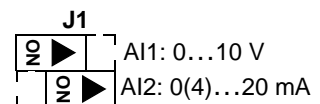



### Application Macro: PFC

This macro provides parameter settings for pump and fan control (PFC) applications. To enable, set the value of parameter 9902 to 7 (PFC CONTROL).

**Note!** Parameter 2108 START INHIBIT must remain in the default setting, 0 (OFF).

Connection example:

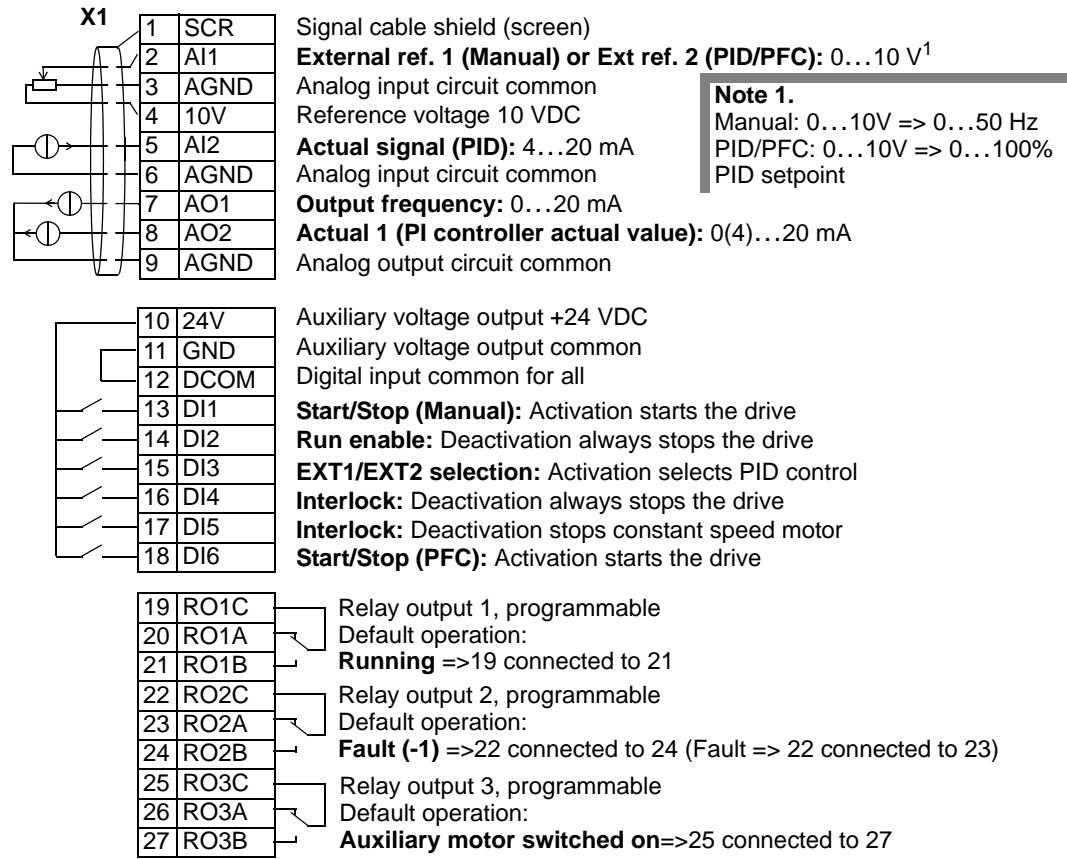

**Note 1.**  
 Manual: 0...10V => 0...50 Hz  
 PID/PFC: 0...10V => 0...100%  
 PID setpoint

- |  |  |                              |
|--|--|------------------------------|
| <p><b>Input signals</b></p> <ul style="list-style-type: none"> <li>• Analog ref. and actual (AI1, 2)</li> <li>• Start/stop – manual/PFC (DI1, 6)</li> <li>• Run enable (DI2)</li> <li>• EXT1/EXT2 selection (DI3)</li> <li>• Interlock (DI4, 5)</li> </ul> | <p><b>Output signals</b></p> <ul style="list-style-type: none"> <li>• Analog output AO1: Frequency</li> <li>• Analog output AO2: Actual 1</li> <li>• Relay output 1: Running</li> <li>• Relay output 2: Fault (-1)</li> <li>• Relay output 3: Aux. motor ON</li> </ul> | <p><b>Jumper Setting</b></p> |
|--|--|------------------------------|

### Application Macro: Torque Control

This macro provides parameter settings for applications that require torque control of the motor. Control can also be switched to speed control. To enable, set the value of parameter 9902 to 8 (TORQUE CONTROL).

Connection example:

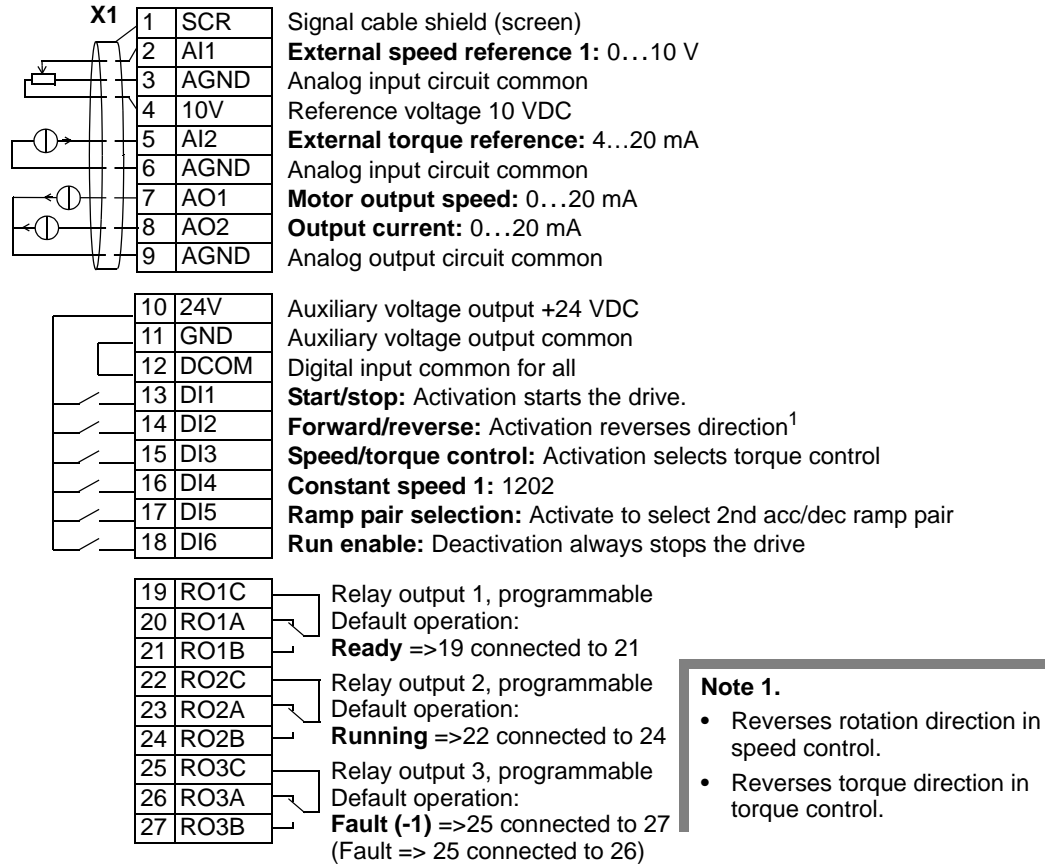

**Note 1.**

- Reverses rotation direction in speed control.
- Reverses torque direction in torque control.

- |  |   |   |
|--|---|---|
| <p><b>Input signals</b></p> <ul style="list-style-type: none"> <li>Two analog references (AI1, 2)</li> <li>Start/stop and direction (DI1, 2)</li> <li>Speed/torque control (DI3)</li> <li>Constant speed selection (DI4)</li> <li>Ramp pair 1/2 selection (DI5)</li> <li>Run enable (DI6)</li> </ul> | <p><b>Output signals</b></p> <ul style="list-style-type: none"> <li>Analog output AO1: Speed</li> <li>Analog output AO2: Current</li> <li>Relay output 1: Ready</li> <li>Relay output 2: Running</li> <li>Relay output 3: Fault (-1)</li> </ul> | <p><b>Jumper Setting</b></p> <p>AI1: 0...10 V<br/>AI2: 0(4)...20 mA</p> |
|--|---|---|

## Macro Default Values for Parameters

Parameter default values are listed in "Complete Parameter List for ACS550". Changing from the default macro (ABB Standard), that is, editing the value of parameter 9902, changes the parameter default values as defined in the following tables.

**Note!** There are two sets of values because the defaults are configured for 50 Hz/ IEC compliance (ACS550-01) and 60 Hz/NEMA compliance (ACS550-U1).

### ACS550-01

Parameter		ABB Standard	3-wire	Alternate	Motor Potentiometer	Hand-auto	PID Control	PFC Control	Torque Control
9902	APPLIC MACRO	1	2	3	4	5	6	7	8
9904	MOTOR CTRL MODE	3	1	1	1	1	1	3	2
1001	EXT1 COMMANDS	2	4	9	2	2	1	1	2
1002	EXT2 COMMANDS	0	0	0	0	7	6	6	2
1003	DIRECTION	3	3	3	3	3	1	1	3
1102	EXT1/EXT2 SEL	0	0	0	0	3	2	3	3
1103	REF1 SELECT	1	1	1	12	1	1	1	1
1106	REF2 SELECT	2	2	2	2	2	19	19	2
1201	CONST SPEED SEL	9	10	9	5	0	9	0	4
1304	MINIMUM AI2	0	0	0	0	20	20	20	20
1401	RELAY OUTPUT 1	1	1	1	1	1	1	2	1
1402	RELAY OUTPUT 2	2	2	2	2	2	2	3	2
1403	RELAY OUTPUT 3	3	3	3	3	3	3	31	3
1501	AO1 CONTENT	103	102	102	102	102	102	103	102
1503	AO1 CONTENT MAX	50	50	50	50	50	50	52	50
1507	AO2 CONTENT	104	104	104	104	104	104	130	104
1510	MINIMUM AO2	0	0	0	0	0	0	4	0
1601	RUN ENABLE	0	0	6	6	4	5	2	6
2008	MAXIMUM FREQ	50	50	50	50	50	50	52	50
2201	ACC/DEC 1/2 SEL	5	0	5	0	0	0	0	5
3201	SUPERV 1 PARAM	103	102	102	102	102	102	103	102
3401	SIGNAL 1 PARAM	103	102	102	102	102	102	103	102
4001	GAIN	10	10	10	10	10	10	25	10
4002	INTEGRATION TIME	60	60	60	60	60	60	3	60
4101	GAIN	1	1	1	1	1	1	2,5	1
4102	INTEGRATION TIME	60	60	60	60	60	60	3	60
8123	PFC ENABLE	0	0	0	0	0	0	1	0

## ACS550-U1

Parameter		ABB Standard	3-wire	Alternate	Motor Potentiometer	Hand-auto	PID Control	PFC Control	Torque Control
9902	APPLIC MACRO	1	2	3	4	5	6	7	8
9904	MOTOR CTRL MODE	3	1	1	1	1	1	3	2
1001	EXT1 COMMANDS	2	4	9	2	2	1	1	2
1002	EXT2 COMMANDS	0	0	0	0	7	6	6	2
1003	DIRECTION	3	3	3	3	3	1	1	3
1102	EXT1/EXT2 SEL	0	0	0	0	3	2	3	3
1103	REF1 SELECT	1	1	1	12	1	1	1	1
1106	REF2 SELECT	2	2	2	2	2	19	19	2
1201	CONST SPEED SEL	9	10	9	5	0	9	0	4
1304	MINIMUM AI2	0	0	0	0	20	20	20	20
1401	RELAY OUTPUT 1	1	1	1	1	1	1	2	1
1402	RELAY OUTPUT 2	2	2	2	2	2	2	3	2
1403	RELAY OUTPUT 3	3	3	3	3	3	3	31	3
1501	AO1 CONTENT	103	102	102	102	102	102	103	102
1503	AO1 CONTENT MAX	60	60	60	60	60	60	62	60
1507	AO2 CONTENT	104	104	104	104	104	104	130	104
1510	MINIMUM AO2	0	0	0	0	0	0	4	0
1601	RUN ENABLE	0	0	6	6	4	5	2	6
2008	MAXIMUM FREQ	60	60	60	60	60	60	62	60
2201	ACC/DEC 1/2 SEL	5	0	5	0	0	0	0	5
3201	SUPERV 1 PARAM	103	102	102	102	102	102	103	102
3401	SIGNAL 1 PARAM	103	102	102	102	102	102	103	102
4001	GAIN	10	10	10	10	10	10	25	10
4002	INTEGRATION TIME	60	60	60	60	60	60	3	60
4101	GAIN	1	1	1	1	1	1	2,5	1
4102	INTEGRATION TIME	60	60	60	60	60	60	3	60
8123	PFC ENABLE	0	0	0	0	0	0	1	0

## Complete Parameter List for ACS550

The following table lists all parameters. Table header abbreviations are:

- S = Parameters can be modified only when the drive is stopped.
- User = Space to enter desired parameter values

Some values depend on the “construction” as indicated in the table by “01:” or “U1:”. Refer to the type code on the drive, for example ACS550-01..

Code	Name	Range	Resolution	Default	User	S
<b>Group 99: Start-Up Data</b>						
9901	LANGUAGE	0...13	1	0		
9902	APPLIC MACRO	-3...8	1	1		✓
9904	MOTOR CTRL MODE	1=VECTOR: SPEED, 2=VECTOR: TORQUE, 3=SCALAR: SPEED	1	3		✓
9905	MOTOR NOM VOLT	115...345 V	1 V	230 V		✓
		01: 200...600 V / U1: 230...690 V	1 V	01: 400 V / U1: 460 V		✓
		U1: 288...862 V	1 V	U1: 575 V		✓
9906	MOTOR NOM CURR	$0.2 \cdot I_{2hd} \dots 2.0 \cdot I_{2hd}$	0.1 A	$1.0 \cdot I_{2hd}$		✓
9907	MOTOR NOM FREQ	10.0...500 Hz	0.1 Hz	01: 50 Hz / U1: 60 Hz		✓
9908	MOTOR NOM SPEED	50...30,000 rpm	1 rpm	Size dependent		✓
9909	MOTOR NOM POWER	$0.2 \dots 3.0 \cdot P_{hd}$	01: 0.1 kW / U1: 0.1 HP	$1.0 \cdot P_{hd}$		✓
9910	MOTOR ID RUN	0 = OFF, 1 = ON	1	0		✓
<b>Group 01: Operating Data</b>						
0102	SPEED	0...30000 rpm	1 rpm	-		
0103	OUTPUT FREQ	0.0...500.0 Hz	0.1 Hz	-		
0104	CURRENT	$0 \dots 2.0 \cdot I_{2hd}$	0.1 A	-		
0105	TORQUE	-200...200%	0.1%	-		
0106	POWER	$-2.0 \dots 2.0 \cdot P_{hd}$	0.1 kW	-		
0107	DC BUS VOLTAGE	$0 \dots 2.5 \cdot V_{dN}$	1 V	-		
0109	OUTPUT VOLTAGE	$0 \dots 2.0 \cdot V_{dN}$	1 V	-		
0110	DRIVE TEMP	0...150 °C	0.1 °C	-		
0111	EXTERNAL REF 1	0...30000 rpm / 0...500 Hz	1 rpm / 0.1 Hz	-		
0112	EXTERNAL REF 2	0...100% (0...600% for torque)	0.1%	-		
0113	CTRL LOCATION	0 = local, 1 = ext1, 2 = ext2	1	-		
0114	RUN TIME (R)	0...9999 h	1 h	0 h		
0115	KWH COUNTER (R)	0...9999 kWh	1 kWh	-		
0116	APPL BLK OUTPUT	0...100% (0...600% for torque)	0.1%	-		
0118	DI 1-3 STATUS	000...111 (0...7 decimal)	1	-		
0119	DI 4-6 STATUS	000...111 (0...7 decimal)	1	-		
0120	AI1	0...100%	0.1%	-		
0121	AI2	0...100%	0.1%	-		
0122	RO 1-3 STATUS	000...111 (0...7 decimal)	1	-		
0123	RO 4-6 STATUS	000...111 (0...7 decimal)	1	-		
0124	AO1	0...20 mA	0.1 mA	-		

Code	Name	Range	Resolution	Default	User	S
0125	AO2	0...20 mA	0.1 mA	-		
0126	PID 1 OUTPUT	-1000...1000%	0.1%	-		
0127	PID 2 OUTPUT	-100...100%	0.1%	-		
0128	PID 1 SETPNT	Unit and scale defined by par. 4006/ 4106 and 4007/4107	-	-		
0129	PID 2 SETPNT	Unit and scale defined by par. 4206 and 4207	-	-		
0130	PID 1 FBK	Unit and scale defined by par. 4006/ 4106 and 4007/4107	-	-		
0131	PID 2 FBK	Unit and scale defined by par. 4206 and 4207	-	-		
0132	PID 1 DEVIATION	Unit and scale defined by par. 4006/ 4106 and 4007/4107	-	-		
0133	PID 2 DEVIATION	Unit and scale defined by par. 4206 and 4207	-	-		
0134	COMM RO WORD	0...65535	1	0		
0135	COMM VALUE 1	-32768...+32767	1	0		
0136	COMM VALUE 2	-32768...+32767	1	0		
0137	PROCESS VAR 1	-	1			
0138	PROCESS VAR 2	-	1			
0139	PROCESS VAR 3	-	1			
0140	RUN TIME	0...499.99 kh	0.01 kh	0 kh		
0141	MWH COUNTER	0...9999 MWh	1 MWh	-		
0142	REVOLUTION CNTR	0...65535	1	0		
0143	DRIVE ON TIME (HI)	Days	1 day	0		
0144	DRIVE ON TIME (LO)	hh.mm.ss	1 = 2s	0		
0145	MOTOR TEMP	-10...200 °C/ 0...5000 Ohm / 0...1	1	0		
0146	MECH ANGLE	0...32767	1 ( $\cong$ 0.01°)	0		
0147	MECH REVS	-32767...32767	1	0		
0148	Z PLS DETECTED	0, 1	1	0		
<b>Group 03: FB Actual Signals</b>						
0301	FB CMD WORD 1	-	-	-		
0302	FB CMD WORD 2	-	-	-		
0303	FB STS WORD 1	-	-	-		
0304	FB STS WORD 2	-	1	0		
0305	FAULT WORD 1	-	1	0		
0306	FAULT WORD 2	-	1	0		
0307	FAULT WORD 3	-	1	0		
0308	ALARM WORD 1	-	1	0		
0309	ALARM WORD 2	-	1	0		
<b>Group 04: Fault History</b>						
0401	LAST FAULT	Fault codes (panel displays as text)	1	0		
0402	FAULT TIME 1	Date dd.mm.yy / power-on time in days	1	0		
0403	FAULT TIME 2	Time hh.mm.ss	2 s	0		
0404	SPEED AT FLT	-	1 rpm	0		
0405	FREQ AT FLT	-	0.1 Hz	0		
0406	VOLTAGE AT FLT	-	0.1 V	0		

Code	Name	Range	Resolution	Default	User	S
0407	CURRENT AT FLT	-	0.1 A	0		
0408	TORQUE AT FLT	-	0.1%	0		
0409	STATUS AT FLT	-	1	0		
0410	DI 1-3 AT FLT	000...111 (0...7 decimal)	1	0		
0411	DI 4-6 AT FLT	000...111 (0...7 decimal)	1	0		
0412	PREVIOUS FAULT 1	as Par. 0401	1	0		
0413	PREVIOUS FAULT 2	as Par. 0401	1	0		
<b>Group 10: Start/Stop/Dir</b>						
1001	EXT1 COMMANDS	0...14	1	2		✓
1002	EXT2 COMMANDS	0...14	1	0		✓
1003	DIRECTION	1...3	1	3		✓
<b>Group 11: Reference Select</b>						
1101	KEYPAD REF SEL	1...2	1	1		
1102	EXT1/EXT2 SEL	-6...12	1	0		✓
1103	REF1 SELECT	0...17	1	1		✓
1104	REF1 MIN	0...500 Hz / 0...30000 rpm	0.1 Hz / 1 rpm	0 Hz / 0 rpm		
1105	REF1 MAX	0...500 Hz / 0...30000 rpm	0.1 Hz / 1 rpm	01: 50 Hz / 1500 rpm U1: 60 Hz / 1800 rpm		
1106	REF2 SELECT	0...19	1	2		✓
1107	REF2 MIN	0...100% (0...600% for torque)	0.1%	0%		
1108	REF2 MAX	0...100% (0...600% for torque)	0.1%	100%		
<b>Group 12: Constant Speeds</b>						
1201	CONST SPEED SEL	-14 ...19	1	9		✓
1202	CONST SPEED 1	0...30000 rpm / 0...500 Hz	1 rpm / 0.1 Hz	01: 300 rpm / 5 Hz U1: 360 rpm / 6 Hz		
1203	CONST SPEED 2	0...30000 rpm / 0...500 Hz	1 rpm / 0.1 Hz	01: 600 rpm / 10 Hz U1: 720 rpm / 12 Hz		
1204	CONST SPEED 3	0...30000 rpm / 0...500 Hz	1 rpm / 0.1 Hz	01: 900 rpm / 15 Hz U1: 1080 rpm / 18 Hz		
1205	CONST SPEED 4	0...30000 rpm / 0...500 Hz	1 rpm / 0.1 Hz	01: 1200 rpm / 20 Hz U1: 1440 rpm / 24 Hz		
1206	CONST SPEED 5	0...30000 rpm / 0...500 Hz	1 rpm / 0.1 Hz	01: 1500 rpm / 25 Hz U1: 1800 rpm / 30 Hz		
1207	CONST SPEED 6	0...30000 rpm / 0...500 Hz	1 rpm / 0.1 Hz	01: 2400 rpm / 40 Hz U1: 2880 rpm / 48 Hz		
1208	CONST SPEED 7	0...30000 rpm / 0...500 Hz	1 rpm / 0.1 Hz	01: 3000 rpm / 50 Hz U1: 3600 rpm / 60 Hz		
1209	TIMED MODE SEL	1...2	1	2		✓
<b>Group 13: Analogue Inputs</b>						
1301	MINIMUM AI1	0...100%	0.1%	0%		
1302	MAXIMUM AI1	0...100%	0.1%	100%		
1303	FILTER AI1	0...10 s	0.1 s	0.1 s		
1304	MINIMUM AI2	0...100%	0.1%	0%		
1305	MAXIMUM AI2	0...100%	0.1%	100%		
1306	FILTER AI2	0...10 s	0.1 s	0.1 s		

Code	Name	Range	Resolution	Default	User	S
<b>Group 14: Relay Outputs</b>						
1401	RELAY OUTPUT 1	0...45	1	1		
1402	RELAY OUTPUT 2	0...45	1	2		
1403	RELAY OUTPUT 3	0...45	1	3		
1404	RO 1 ON DELAY	0...3600 s	0.1 s	0 s		
1405	RO 1 OFF DELAY	0...3600 s	0.1 s	0 s		
1406	RO 2 ON DELAY	0...3600 s	0.1 s	0 s		
1407	RO 2 OFF DELAY	0...3600 s	0.1 s	0 s		
1408	RO 3 ON DELAY	0...3600 s	0.1 s	0 s		
1409	RO 3 OFF DELAY	0...3600 s	0.1 s	0 s		
1410	RELAY OUTPUT 4	0...45	1	0		
1411	RELAY OUTPUT 5	0...45	1	0		
1412	RELAY OUTPUT 6	0...45	1	0		
1413	RO 4 ON DELAY	0...3600 s	0.1 s	0 s		
1414	RO 4 OFF DELAY	0...3600 s	0.1 s	0 s		
1415	RO 5 ON DELAY	0...3600 s	0.1 s	0 s		
1416	RO 5 OFF DELAY	0...3600 s	0.1 s	0 s		
1417	RO 6 ON DELAY	0...3600 s	0.1 s	0 s		
1418	RO 6 OFF DELAY	0...3600 s	0.1 s	0 s		
<b>Group 15: Analogue Outputs</b>						
1501	AO1 CONTENT SEL	99...199	1	103		
1502	AO1 CONTENT MIN	-	-	Defined by par. 0103		
1503	AO1 CONTENT MAX	-	-	Defined by par. 0103		
1504	MINIMUM AO1	0.0...20.0 mA	0.1 mA	0 mA		
1505	MAXIMUM AO1	0.0...20.0 mA	0.1 mA	20.0 mA		
1506	FILTER AO1	0...10 s	0.1 s	0.1 s		
1507	AO2 CONTENT SEL	99...199	1	104		
1508	AO2 CONTENT MIN	-	-	Defined by par. 0104		
1509	AO2 CONTENT MAX	-	-	Defined by par. 0104		
1510	MINIMUM AO2	0.0...20.0 mA	0.1 mA	0 mA		
1511	MAXIMUM AO2	0.0...20.0 mA	0.1 mA	20.0 mA		
1512	FILTER AO2	0...10 s	0.1 s	0.1 s		
<b>Group 16: System Controls</b>						
1601	RUN ENABLE	0...7, -1...-6	1	0		✓
1602	PARAMETER LOCK	0...2	1	1		
1603	PASS CODE	0...65535	1	0		
1604	FAULT RESET SEL	0...8, -1...-6	1	0		
1605	USER PAR SET CHG	0...6, -1...-6	1	0		
1606	LOCAL LOCK	0...8, -1...-6	1	0		
1607	PARAM SAVE	0 = DONE, 1 = SAVE	1	0		
1608	START ENABLE 1	0...7, -1...-6	1	0		
1609	START ENABLE 2	0...7, -1...-6	1	0		
1610	DISPLAY ALARMS	0...1	1	0		
<b>Group 20: Limits</b>						
2001	MINIMUM SPEED	-30000...30000 rpm	1 rpm	0 rpm		✓



Code	Name	Range	Resolution	Default	User	S
2002	MAXIMUM SPEED	0...30000 rpm	1 rpm	01: 1500 rpm / U1: 1800 rpm		✓
2003	MAX CURRENT	0... 1.8 * I <sub>2hd</sub>	0.1 A	1.8 * I <sub>2hd</sub>		✓
2005	OVERVOLT CTRL	0 = DISABLE, 1 = ENABLE	1	1		
2006	UNDERVOLT CTRL	0 = DISABLE, 1 = ENABLE (TIME), 2 = ENABLE	1	1		
2007	MINIMUM FREQ	-500...500 Hz	0.1 Hz	0 Hz		✓
2008	MAXIMUM FREQ	0...500 Hz	0.1 Hz	01: 50 Hz / U1: 60 Hz		✓
2013	MIN TORQUE SEL	0...7, -1...-6	1	0		
2014	MAX TORQUE SEL	0...7, -1...-6	1	0		
2015	MIN TORQUE 1	-600.0%...0%	0.1%	-300.0%		
2016	MIN TORQUE 2	-600.0%...0%	0.1%	-300.0%		
2017	MAX TORQUE 1	0%...600.0%	0.1%	300.0%		
2018	MAX TORQUE 2	0%...600.0%	0.1%	300.0%		
<b>Group 21: Start/Stop</b>						
2101	START FUNCTION	1...5	1	1		✓
2102	STOP FUNCTION	1 = COAST, 2 = RAMP	1	1		
2103	DC MAGN TIME	0...10 s	0.01 s	0.3 s		
2104	DC CURR CTL	0, 2	-	0		✓
2105	DC HOLD SPEED	0...360 rpm	1 rpm	5 rpm		
2106	DC CURR REF	0%...100%	1%	30%		
2107	DC BRAKE TIME	0...250 s	0.1 s	0 s		
2108	START INHIBIT	0 = OFF, 1 = ON	1	0		✓
2109	EM STOP SEL	0...6, -1...-6	1	0		
2110	TORQ BOOST CURR	15...300%	1	100%		
<b>Group 22: Accel/Decel</b>						
2201	ACC/DEC 1/2 SEL	0...7, -1...-6	1	5		
2202	ACCELER TIME 1	0.0...1800 s	0.1 s	5 s		
2203	DECELER TIME 1	0.0...1800 s	0.1 s	5 s		
2204	RAMP SHAPE 1	0=LINEAR; 0.1...1000.0 s	0.1 s	0.0 s		
2205	ACCELER TIME 2	0.0...1800 s	0.1 s	60 s		
2206	DECELER TIME 2	0.0...1800 s	0.1 s	60 s		
2207	RAMP SHAPE 2	0=LINEAR; 0.1...1000.0 s	0.1 s	0.0 s		
2208	EM DEC TIME	0.0...1800 s	0.1 s	1.0 s		
2209	RAMP INPUT 0	0...6, -1...-6	1	0		
<b>Group 23: Speed Control</b>						
2301	PROP GAIN	0.00...200.0	0.01	10		
2302	INTEGRATION TIME	0...600.00 s	0.01 s	2.5		
2303	DERIVATION TIME	0...10000 ms	1 ms	0		
2304	ACC COMPENSATION	0...600.00 s	0.01 s	0		
2305	AUTOTUNE RUN	0 = OFF, 1 = ON	1	0 (OFF)		
<b>Group 24: Torque Control</b>						
2401	TORQ RAMP UP	0.00...120.00 s	0.01 s	0		
2402	TORQ RAMP DOWN	0.00...120.00 s	0.01 s	0		
<b>Group 25: Critical Speeds</b>						

Code	Name	Range	Resolution	Default	User	S
2501	CRIT SPEED SEL	0 = OFF, 1 = ON	1	0		
2502	CRIT SPEED 1 LO	0...30000 rpm / 0...500 Hz	1 rpm / 0.1 Hz	0 rpm / 0 Hz		
2503	CRIT SPEED 1 HI	0...30000 rpm / 0...500 Hz	1 rpm / 0.1 Hz	0 rpm / 0 Hz		
2504	CRIT SPEED 2 LO	0...30000 rpm / 0...500 Hz	1 rpm / 0.1 Hz	0 rpm / 0 Hz		
2505	CRIT SPEED 2 HI	0...30000 rpm / 0...500 Hz	1 rpm / 0.1 Hz	0 rpm / 0 Hz		
2506	CRIT SPEED 3 LO	0...30000 rpm / 0...500 Hz	1 rpm / 0.1 Hz	0 rpm / 0 Hz		
2507	CRIT SPEED 3 HI	0...30000 rpm / 0...500 Hz	1 rpm / 0.1 Hz	0 rpm / 0 Hz		
<b>Group 26: Motor Control</b>						
2601	FLUX OPTIMIZATION	0 = OFF, 1 = ON	1	0		
2602	FLUX BRAKING	0 = OFF, 1 = ON	1	0		
2603	IR COMP VOLT	0...100 V	1	size dependent		
2604	IR COMP FREQ	0...100%	1	80%		
2605	U/F RATIO	1 = LINEAR, 2 = SQUARED	1	1		
2606	SWITCHING FREQ	1,4,8, 12 kHz	-	4 kHz		
2607	SW FREQ CTRL	0 = OFF, 1 = ON	-	1		
2608	SLIP COMP RATIO	0...200%	1	0		
2609	NOISE SMOOTHING	0 = DISABLE, 1 = ENABLE	1	0		
<b>Group 29: Maintenance Trig</b>						
2901	COOLING FAN TRIG	0.0...6553.5 kh	0.1 kh	0.0 (NOT SEL)		
2902	COOLING FAN ACT	0.0...6553.5 kh	0.1 kh	0.0 kh		
2903	REVOLUTION TRIG	0...65535 MRev	1 MRev	0 (NOT SEL)		
2904	REVOLUTION ACT	0...65535 MRev	1 MRev	0 MRev		
2905	RUN TIME TRIG	0.0...6553.5 kh	0.1 kh	0 (NOT SEL)		
2906	RUN TIME ACT	0.0...6553.5 kh	0.1 kh	0.0 kh		
2907	USER MWH TRIG	0.0...6553.5 MWh	0.1 MWh	0 (NOT SEL)		
2901	USER MWH ACT	0.0...6553.5 MWh	0.1 MWh	0.0 MWh		
<b>Group 30: Fault Functions</b>						
3001	AI<MIN FUNCTION	0...3	1	0		
3002	PANEL COMM ERR	1...3	1	1		
3003	EXTERNAL FAULT 1	0...6, -1...-6	1	0		
3004	EXTERNAL FAULT 2	0...6, -1...-6	1	0		
3005	MOT THERM PROT	0 = NOT SEL, 1 = FAULT, 2 = WARNING	1	1 (FAULT)		
3006	MOT THERM TIME	256...9999 s	1	500 s		
3007	MOT LOAD CURVE	50...150%	1	100%		
3008	ZERO SPEED LOAD	25...150%	1	70%		
3009	BREAK POINT FREQ	1...250 Hz	1	35 Hz		
3010	STALL FUNCTION	0...2	1	0 (NOT SEL)		
3011	STALL FREQUENCY	0.5...50 Hz	0.1 Hz	20 Hz		
3012	STALL TIME	10...400 s	1 s	20 s		
3013	UNDERLOAD FUNC	0 = NOT SEL, 1 = FAULT, 2 = WARNING	-	0 (NOT SEL)		
3014	UNDERLOAD TIME	10...400 s	1 s	20 s		
3015	UNDERLOAD CURVE	1...5	1	1		
3017	EARTH FAULT	0 = DISABLE, 1 = ENABLE	1	1 (ENABLE)		
3018	COMM FAULT FUNC	0 = NOT SEL, 1 = FAULT, 2 = CONST SP7, 3 = LAST SPEED	1	0 (NOT SEL)		

Code	Name	Range	Resolution	Default	User	S
3019	COMM FAULT TIME	0...60.0 s	0.1 s	3.0 s		
3021	AI1 FAULT LIMIT	0...100%	0.1%	0%		
3022	AI2 FAULT LIMIT	0...100%	0.1%	0%		
3023	WIRING FAULT	0 = DISABLE, 1 = ENABLE	1	1		
<b>Group 31: Automatic Reset</b>						
3101	NR OF TRIALS	0...5	1	0		
3102	TRIAL TIME	1.0...600.0 s	0.1 s	30 s		
3103	DELAY TIME	0.0...120.0 s	0.1 s	0 s		
3104	AR OVERCURRENT	0 = DISABLE, 1 = ENABLE	1	0 (DISABLE)		
3105	AR OVERVOLTAGE	0 = DISABLE, 1 = ENABLE	1	0 (DISABLE)		
3106	AR UNDERVOLTAGE	0 = DISABLE, 1 = ENABLE	1	0 (DISABLE)		
3107	AR AI<MIN	0 = DISABLE, 1 = ENABLE	1	0 (DISABLE)		
3108	AR EXTERNAL FLT	0 = DISABLE, 1 = ENABLE	1	0 (DISABLE)		
<b>Group 32: Supervision</b>						
3201	SUPERV 1 PARAM	101...199	1	103		
3202	SUPERV 1 LIM LO	-	-	0		
3203	SUPERV 1 LIM HI	-	-	0		
3204	SUPERV 2 PARAM	101...199	1	103		
3205	SUPERV 2 LIM LO	-	-	0		
3206	SUPERV 2 LIM HI	-	-	0		
3207	SUPERV 3 PARAM	101...199	1	103		
3208	SUPERV 3 LIM LO	-	-	0		
3209	SUPERV 3 LIM HI	-	-	0		
<b>Group 33: Information</b>						
3301	FW VERSION	0000...FFFF hex	1	Firmware version		
3302	LP VERSION	0000...FFFF hex	1	0		
3303	TEST DATE	yy.ww	1	0		
3304	DRIVE RATING	-	-	-		
<b>Group 34: Panel Display / Process Variables</b>						
3401	SIGNAL 1 PARAM	100...199	1	103		
3402	SIGNAL 1 MIN	-	1	-		
3403	SIGNAL 1 MAX	-	1	-		
3404	OUTPUT 1 DSP FORM	0...9	1	9		
3405	OUTPUT 1 UNIT	0...127	1	.		
3406	OUTPUT 1 MIN	-	1	-		
3407	OUTPUT 1 MAX	-	1	-		
3408	SIGNAL 2 PARAM	100...199	1	104		
3409	SIGNAL 2 MIN	-	1	-		
3410	SIGNAL 2 MAX	-	1	-		
3411	OUTPUT 2 DSP FORM	0...8	1	-		
3412	OUTPUT 2 UNIT	-128...127	1	.		
3413	OUTPUT 2 MIN	-	1	-		
3414	OUTPUT 2 MAX	-	1	-		
3415	SIGNAL 3 PARAM	100...199	1	105		
3416	SIGNAL 3 MIN	-	1	-		

Code	Name	Range	Resolution	Default	User	S
3417	SIGNAL 3 MAX	-	1	-		
3418	OUTPUT 3 DSP FORM	0...8	1	-		
3419	OUTPUT 3 UNIT	-128...127	1	.		
3420	OUTPUT 3 MIN	-	1	-		
3421	OUTPUT 3 MAX	-	1	-		
<b>Group 35: Motor Temp Meas</b>						
3501	SENSOR TYPE	0...6	1	0		
3502	INPUT SELECTION	1...8	1	1		
3503	ALARM LIMIT	-10...200 °C / 0...5000 Ohm / 0...1	1	110 °C / 1500 Ohm / 0		
3504	FAULT LIMIT	-10...200 °C / 0...5000 Ohm / 0...1	1	130 °C / 4000 Ohm / 0		
<b>Group 36: Timer Functions</b>						
3601	TIMERS ENABLE	-6...7	1	0		
3602	START TIME 1	00:00:00...23:59:58	2 s	00:00:00		
3603	STOP TIME 1	00:00:00...23:59:58	2 s	00:00:00		
3604	START DAY 1	1...7	1	1		
3605	STOP DAY 1	1...7	1	1		
3606	START TIME 2	00:00:00...23:59:58	2 s	00:00:00		
3607	STOP TIME 2	00:00:00...23:59:58	2 s	00:00:00		
3608	START DAY 2	1...7	1	1		
3609	STOP DAY 2	1...7	1	1		
3610	START TIME 3	00:00:00...23:59:58	2 s	00:00:00		
3611	STOP TIME 3	00:00:00...23:59:58	2 s	00:00:00		
3612	START DAY 3	1...7	1	1		
3613	STOP DAY 3	1...7	1	1		
3614	START TIME 4	00:00:00...23:59:58	2 s	00:00:00		
3615	STOP TIME 4	00:00:00...23:59:58	2 s	00:00:00		
3616	START DAY 4	1...7	1	1		
3617	STOP DAY 4	1...7	1	1		
3622	BOOSTER SEL	-6...6	1	0		
3623	BOOSTER TIME	00:00:00...23:59:58	2 s	00:00:00		
3624	TMR FUNC1...4 SRC	0...31	1	0		
...						
3628						
<b>Group 40: Process PID Set 1</b>						
4001	GAIN	0.1...100	0.1	1.0		
4002	INTEGRATION TIME	0.0s = NOT SEL, 0.1...3600 s	0.1 s	60 s		
4003	DERIVATION TIME	0...10 s	0.1 s	0 s		
4004	PID DERIV FILTER	0...10 s	0.1 s	1 s		
4005	ERROR VALUE INV	0 = NO, 1 = YES	-	0		
4006	UNITS	0...31	-	4		
4007	UNIT SCALE	0...4	1	1		
4008	0% VALUE	Unit and scale defined by par. 4006 and 4007	1	0.0%		
4009	100% VALUE	Unit and scale defined by par. 4006 and 4007	1	100%		
4010	SET POINT SEL	0...19	1	1		✓

Code	Name	Range	Resolution	Default	User	S
4011	INTERNAL SETPNT	Unit and scale defined by par. 4006 and 4007	1	40.0%		
4012	SETPOINT MIN	-500.0%...500.0%	0.1%	0%		
4013	SETPOINT MAX	-500.0%...500.0%	0.1%	100%		
4014	FBK SEL	1...10	-	1		
4015	FBK MULTIPLIER	-32.768...32.767 (0 = not used)	0.001	0		
4016	ACT1 INPUT	1...5	-	2		✓
4017	ACT2 INPUT	1...5	-	2		✓
4018	ACT1 MINIMUM	-1000...1000%	1%	0%		
4019	ACT1 MAXIMUM	-1000...1000%	1%	100%		
4020	ACT2 MINIMUM	-1000...1000%	1%	0%		
4021	ACT2 MAXIMUM	-1000...1000%	1%	100%		
4022	SLEEP SELECTION	0...7, -1...-6	-	0		
4023	PID SLEEP LEVEL	0...7200 rpm / 0.0...120 Hz	1 rpm / 0.1 Hz	0 Hz		
4024	PID SLEEP DELAY	0.0...3600 s	0.1 s	60 s		
4025	WAKE-UP DEV	Unit and scale defined by par. 4006 and 4007	1	-		
4026	WAKE-UP DELAY	0...60 s	0.01 s	0.50 s		
4027	PID 1 PARAM SET	-6...11	1	0		
<b>Group 41: Process PID Set 2</b>						
4101	GAIN	0.1...100	0.1	1.0		
4102	INTEGRATION TIME	0.0s = NOT SEL, 0.1...3600 s	0.1 s	60 s		
4103	DERIVATION TIME	0...10 s	0.1 s	0 s		
4104	PID DERIV FILTER	0...10 s	0.1 s	1 s		
4105	ERROR VALUE INV	0 = NO, 1 = YES	-	0		
4106	UNITS	0...31	-	4		
4107	UNIT SCALE	0...4	1	1		
4108	0% VALUE	Unit and scale defined by par. 4106 and 4107	1	0.0%		
4109	100% VALUE	Unit and scale defined by par. 4106 and 4107	1	100%		
4110	SET POINT SEL	0...19	1	1		✓
4111	INTERNAL SETPNT	Unit and scale defined by par. 4106 and 4107	1	40.0%		
4112	SETPOINT MIN	-500.0%...500.0%	0.1%	0%		
4113	SETPOINT MAX	-500.0%...500.0%	0.1%	100%		
4114	FBK SEL	1...10	-	1		
4115	FBK MULTIPLIER	-32.768...32.767 (0 = NOT USED)	0.001	0		
4116	ACT1 INPUT	1...5	-	2		✓
4117	ACT2 INPUT	1...5	-	2		✓
4118	ACT1 MINIMUM	-1000...1000%	1%	0%		
4119	ACT1 MAXIMUM	-1000...1000%	1%	100%		
4120	ACT2 MINIMUM	-1000...1000%	1%	0%		
4121	ACT2 MAXIMUM	-1000...1000%	1%	100%		
4122	SLEEP SELECTION	0...7, -1...-6	-	0		
4123	PID SLEEP LEVEL	0...7200 rpm / 0.0...120 Hz	1 rpm / 0.1 Hz	0 Hz		

Code	Name	Range	Resolution	Default	User	S
4124	PID SLEEP DELAY	0.0...3600 s	0.1 s	60 s		
4125	WAKE-UP DEV	Unit and scale defined by par. 4106 and 4107	-	-		
4126	WAKE-UP DELAY	0...60 s	0.01 s	0.50 s		
<b>Group 42: Ext / Trim PID</b>						
4201	GAIN	0.1...100	0.1	1.0		
4202	INTEGRATION TIME	0.0s = NOT SEL, 0.1...3600 s	0.1 s	60 s		
4203	DERIVATION TIME	0...10 s	0.1 s	0 s		
4204	PID DERIV FILTER	0...10 s	0.1 s	1 s		
4205	ERROR VALUE INV	0 = NO, 1 = YES	-	0		
4206	UNITS	0...31	-	4		
4207	UNIT SCALE	0...4	1	1		
4208	0% VALUE	Unit and scale defined by par. 4206 and 4207	1	0%		
4209	100% VALUE	Unit and scale defined by par. 4206 and 4207	1	100%		
4210	SET POINT SEL	0...19	1	1		✓
4211	INTERNAL SETPNT	Unit and scale defined by par. 4206 and 4207	1	40.0%		
4212	SETPOINT MIN	-500.0%...500.0%	0.1%	0%		
4213	SETPOINT MAX	-500.0%...500.0%	0.1%	100%		
4214	FBK SEL	1...10	-	1		
4215	FBK MULTIPLIER	-32.768...32.767 (0 = NOT USED)	0.001	0		
4216	ACT1 INPUT	1...5	-	2		✓
4217	ACT2 INPUT	1...5	-	2		✓
4218	ACT1 MINIMUM	-1000...1000%	1%	0%		
4219	ACT1 MAXIMUM	-1000...1000%	1%	100%		
4220	ACT2 MINIMUM	-1000...1000%	1%	0%		
4221	ACT2 MAXIMUM	-1000...1000%	1%	100%		
4228	ACTIVATE	-6...12	-	0		
4229	OFFSET	0.0...100.0%	0.1%	0		
4230	TRIM MODE	0...2	1	0		
4231	TRIM SCALE	-100.0%...100.0%	0.1%	0%		
4232	CORRECTION SRC	1...2	1	1 (PID2 REF)		
<b>Group 50: Encoder</b>						
5001	PULSE NR	0...16384 ppr	1	1024		✓
5002	ENCODER ENABLE	0, 1	1	0		✓
5003	ENCODER FAULT	1, 2	1	1		✓
5010	Z PLS ENABLE	0, 1	1	0		✓
5011	POSITION RESET	0, 1	1	0		
<b>Group 51: Ext Comm Module</b>						
5101	FBA TYPE	-	1	0		
5102 ... 5126	FBA PAR 2...26	0...65535	1	0		
5127	FBA PAR REFRESH	0 = done, 1 = refresh	1	0		
5128	FILE CPI FW REV	0...0xFFFF (hex)	1	0		

Code	Name	Range	Resolution	Default	User	S
5129	FILE CONFIG ID	0...0xFFFF (hex)	1	0		
5130	FILE CONFIG REV	0...0xFFFF (hex)	1	0		
5131	FBA STATUS	0...6	1	0		
5132	FBA CPI FW REV	0...0xFFFF (hex)	1	0		
5133	FBA APPL FW REV	0...0xFFFF (hex)	1	0		
<b>Group 52: Panel Communication</b>						
5201	STATION ID	1...247	1	1		
5202	BAUD RATE	9.6, 19.2, 38.4, 57.6, 115.2 kbits/s	-	9.6 kbits/s		
5203	PARITY	0 = 8N1, 1 = 8N2, 2 = 8E1, 3 = 8O1	1	0		
5204	OK MESSAGES	0...65535	1	-		
5205	PARITY ERRORS	0...65535	1	-		
5206	FRAME ERRORS	0...65535	1	-		
5207	BUFFER OVERRUNS	0...65535	1	-		
5208	CRC ERRORS	0...65535	1	-		
<b>Group 53: EFB Protocol</b>						
5301	EFB PROTOCOL ID	0...0xFFFF	1	0		
5302	EFB STATION ID	0...65535	1	1		✓
5303	EFB BAUD RATE	1.2, 2.4, 4.8, ... 38.4, 57.6, 76.8 kbits/s	-	9.6 kbits/s		
5304	EFB PARITY	0 = 8N1, 1 = 8N2, 2 = 8E1, 3 = 8O1		0		
5305	EFB CTRL PROFILE	0 = ABB DRV LIM, 1 = DCU PROFILE, 2 = ABB DRV FULL	1	0 (ABB DRV LIM)		
5306	EFB OK MESSAGES	0...65535	1	0		
5307	EFB CRC ERRORS	0...65535	1	0		
5308	EFB UART ERRORS	0...65535	1	0		
5309	EFB STATUS	0...65535	1	0 (IDLE)		
5310	EFB PAR 10	0...65535	1	0 (NOT SEL)		
5311	EFB PAR 11	0...65535	1	0 (NOT SEL)		
5312	EFB PAR 12	0...65535	1	0 (NOT SEL)		
5313	EFB PAR 13	0...65535	1	0 (NOT SEL)		
5314	EFB PAR 14	0...65535	1	0 (NOT SEL)		
5315	EFB PAR 15	0...65535	1	0 (NOT SEL)		
5316	EFB PAR 16	0...65535	1	0 (NOT SEL)		
5317	EFB PAR 17	0...65535	1	0 (NOT SEL)		
5318	EFB PAR 18	0...65535	1	0		
5319	EFB PAR 19	0...0xFFFF (hex)	1	0		
5320	EFB PAR 20	0...0xFFFF (hex)	1	0		
<b>Group 81: PFC Control</b>						
8103	REFERENCE STEP 1	0.0...100%	0.1%	0%		
8104	REFERENCE STEP 2	0.0...100%	0.1%	0%		
8105	REFERENCE STEP 3	0.0...100%	0.1%	0%		
8109	START FREQ 1	0.0...500 Hz	0.1 Hz	01: 50Hz / U1: 60 Hz		
8110	START FREQ 2	0.0...500 Hz	0.1 Hz	01: 50 Hz/ U1: 60 Hz		
8111	START FREQ 3	0.0...500 Hz	0.1 Hz	01: 50 Hz/ U1: 60 Hz		
8112	LOW FREQ 1	0.0...500 Hz	0.1 Hz	01: 25 Hz/ U1: 30 Hz		
8113	LOW FREQ 2	0.0...500 Hz	0.1 Hz	01: 25 Hz/ U1: 30 Hz		

Code	Name	Range	Resolution	Default	User	S
8114	LOW FREQ 3	0.0...500 Hz	0.1 Hz	01: 25 Hz/ U1: 30 Hz		
8115	AUX MOT START D	0.0...3600 s	0.1 s; 1 s	5 s		
8116	AUX MOT STOP D.	0.0...3600 s	0.1 s; 1 s	3 s		
8117	NR OF AUX MOT	0...4	1	1		✓
8118	AUTOCHNG INTERV	0.0...336 h	0.1 h	0.0 h (NOT SEL)		✓
8119	AUTOCHNG LEVEL	0.0...100.0%	0.1%	50%		
8120	INTERLOCKS	0...6	1	4		✓
8121	REG BYPASS CTRL	0...1	1	0 (NO)		
8122	PFC START DELAY	0...10 s	0.01 s	0.5 s		
8123	PFC ENABLE	0...1	-	0 (NOT SEL)		✓
8124	ACC IN AUX STOP	0.0...1800 s	0.1 s	0.0 s (NOT SEL)		
8125	DEC IN AUX START	0.0...1800 s	0.1 s	0.0 s (NOT SEL)		
8126	TMED AUTOCHNG	0...4	1	0 (NOT SEL)		
8127	MOTORS	1...7	1	0 (NOT SEL)		
<b>Group 98: Options</b>						
9802	COMM PROT SEL	0...4	1	0 (NOT SEL)		✓



## Complete Parameter Descriptions

This section describes the actual signals and parameters for ACS550.

### Group 99: Start-up Data

This group defines special Start-up data required to:

- Set up the drive.
- Enter motor information.

Code	Description
9901	<p><b>LANGUAGE</b> Selects the display language.</p> <p>0 = ENGLISH      1 = ENGLISH (AM)      2 = DEUTSCH      3 = ITALIANO      4 = ESPAÑOL                      5 = PORTUGUES      6 = NEDERLANDS      7 = FRANCAIS      8 = DANSK      9 = SUOMI                      10 = SVENSKA      11 = RUSSKI      12 = POLSKI      13 = TÜRKCE</p>
9902	<p><b>APPLIC MACRO</b> Selects an application macro. Application macros automatically edit parameters to configure the ACS550 for a particular application.</p> <p>1 = ABB STANDARD      2 = 3-WIRE      3 = ALTERNATE      4 = MOTOR POT      5 = HAND/AUTO                      6 = PID CONTROL      7 = PFC CONTROL      8 = TORQUE CTRL                      0 = USER S1 LOAD      -1 = USER S1 SAVE      -2 = USER S2 LOAD      -3 = USER S2 SAVE</p>
9904	<p><b>MOTOR CTRL MODE</b> Selects the motor control mode.</p> <p>1 = VECTOR: SPEED – sensorless vector control mode.                      • Reference 1 is speed reference in rpm.                      • Reference 2 is speed reference in % (100% is absolute maximum speed, equal to the value of parameter 2002 MAXIMUM SPEED, or 2001 MINIMUM SPEED if the absolute value of the minimum speed is greater than the maximum speed).</p> <p>2 = VECTOR: TORQ.                      • Reference 1 is speed reference in rpm.                      • Reference 2 is torque reference in % (100% is nominal torque.)</p> <p>3 = SCALAR: SPEED – scalar control mode.                      • Reference 1 is frequency reference in Hz.                      • Reference 2 is frequency reference in % (100% is absolute maximum frequency, equal to the value of parameter 2008 MAXIMUM FREQUENCY, or 2007 MINIMUM FREQUENCY if the absolute value of the minimum speed is greater than the maximum speed).</p>
9905	<p><b>MOTOR NOM VOLT</b> Defines the nominal motor voltage.</p> <ul style="list-style-type: none"> <li>• Must equal the value on the motor rating plate.</li> <li>• The ACS550 cannot supply the motor with a voltage greater than the mains voltage.</li> </ul>
9906	<p><b>MOTOR NOM CURR</b> Defines the nominal motor current.</p> <ul style="list-style-type: none"> <li>• Must equal the value on the motor rating plate.</li> <li>• Range allowed: <math>(0.2...2.0) \cdot I_{2hd}</math> (where <math>I_{2hd}</math> is drive current).</li> </ul>
9907	<p><b>MOTOR NOM FREQ</b> Defines the nominal motor frequency.</p> <ul style="list-style-type: none"> <li>• Range: 10...500 Hz (typically 50 or 60 Hz)</li> <li>• Sets the frequency at which output voltage equals the MOTOR NOM VOLT.</li> <li>• Field weakening point = Nom Freq * Supply Volt / Mot Nom Volt</li> </ul>

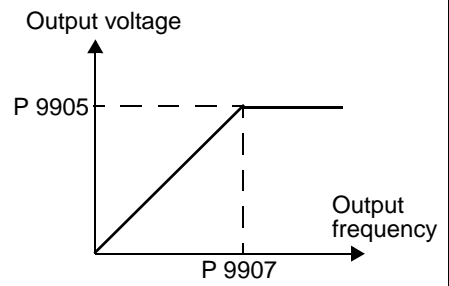

9908	<p><b>MOTOR NOM SPEED</b></p> <p>Defines the nominal motor speed.</p> <ul style="list-style-type: none"> <li>• Must equal the value on the motor rating plate.</li> </ul>
9909	<p><b>MOTOR NOM POWER</b></p> <p>Defines the nominal motor power.</p> <ul style="list-style-type: none"> <li>• Must equal the value on the motor rating plate.</li> </ul>
9910	<p><b>MOTOR ID RUN</b></p> <p>This parameter controls a self-calibration process called the Motor ID Run. During this process, the drive operates the motor and makes measurements in order to identify motor characteristics and create a model used for internal calculations. An ID Run is especially effective when:</p> <ul style="list-style-type: none"> <li>• Operation point is near zero speed.</li> <li>• Operation requires a torque range above the motor nominal torque, over a wide speed range, and without any measured speed feedback (i.e. without a pulse encoder).</li> </ul> <p><b>First Start.</b> If no Motor ID Run is performed, the drive estimates motor characteristics when the drive is first run. This "First Start" occurs automatically* at the next run command after any motor parameter is changed. In order to estimate characteristics and create a motor model, the First Start magnetizes the motor for 10 to 15 seconds at zero speed.</p> <p>* Activating the "First Start" does require that:</p> <ul style="list-style-type: none"> <li>• 9904 = 1 (VECTOR: SPEED), or 9904 = 3 (SCALAR: SPEED) and</li> <li>• 2101 = 3 (SCALAR FLYSTART) or 5 (FLYSTART + TORQ BOOST).</li> </ul> <p><b>Note:</b> If you change motor parameters after running a Motor ID Run, repeat the Motor ID Run.</p> <p>0 = NO ID RUN – Motor ID Run process is not running.  1 = ID RUN – Enables a Motor ID Run at the next start command. After run completion, this value automatically changes to 0.</p> <p>To perform a Motor ID Run:</p> <ol style="list-style-type: none"> <li>1. De-couple load from motor (or otherwise reduce load to near zero).</li> <li>2. Verify that motor operation is safe: <ul style="list-style-type: none"> <li>• The run automatically operates the motor in the forward direction – confirm that forward rotation is safe.</li> <li>• The run automatically operates the motor at 50...80% of nominal speed – confirm that operation at these speeds is safe.</li> </ul> </li> <li>3. Check following parameters (if changed from factory settings): <ul style="list-style-type: none"> <li>• 2001 MINIMUM SPEED <math>\leq 0</math></li> <li>• 2002 MAXIMUM SPEED <math>&gt; 80\%</math> of motor rated speed.</li> <li>• 2003 MAX CURRENT <math>\geq 100\%</math> of <math>I_{2hd}</math> value.</li> <li>• The maximum torque (parameters 2014, 2017 and/or 2018) <math>&gt; 50\%</math>.</li> </ul> </li> <li>4. At the Control Panel, select: <ul style="list-style-type: none"> <li>• Select Parameters</li> <li>• Select Group 99</li> <li>• Select Parameter 9910</li> <li>• Set value to 1 and press Enter – The display shows a warning.</li> <li>• Press START – The display shows the progress of the run.</li> </ul> </li> </ol> <p><b>Note!</b> Pressing STOP, or removing the run enable signal stops the ID Run. In this case you'll need to repeat the Motor ID Run to create the motor model.</p>

## Group 01: Operating Data

This group contains drive operating data, including actual signals. The drive sets the values for actual signals, based on measurements or calculations. You cannot set these values.

Code	Description
0102	<b>SPEED</b> The calculated speed of the motor (rpm).
0103	<b>OUTPUT FREQ</b> The frequency (Hz) applied to the motor. (Also shown by default in OUTPUT display.)
0104	<b>CURRENT</b> The motor current, as measured by the ACS550. (Also shown by default in OUTPUT display.)
0105	<b>TORQUE</b> Output torque. Calculated value of torque on motor shaft in % of motor nominal torque.
0106	<b>POWER</b> The measured motor power in kW.
0107	<b>DC BUS VOLTAGE</b> The DC bus voltage in VDC, as measured by the ACS550.
0109	<b>OUTPUT VOLTAGE</b> The voltage applied to the motor.
0110	<b>DRIVE TEMP</b> The temperature of the drive power transistors in Centigrade.
0111	<b>EXTERNAL REF 1</b> External reference, REF1, in rpm or Hz – units determined by parameter 9904.
0112	<b>EXTERNAL REF 2</b> External reference, REF2, in %.
0113	<b>CTRL LOCATION</b> Active control location. Alternatives are: 0 = LOCAL 1 = EXT1 2 = EXT2
0114	<b>RUN TIME (R)</b> The drive's accumulated running time in hours (h). • Can be <b>reset</b> by pressing UP and DOWN buttons simultaneously when in parameter set mode.
0115	<b>KWH COUNTER (R)</b> The drive's accumulated power consumption in kilowatt hours. • Can be <b>reset</b> by pressing UP and DOWN buttons simultaneously when in parameter set mode.
0116	<b>APPL BLK OUTPUT</b> Application block output signal. Value is from either: • PFC control, if PFC Control is active, or • Parameter 0112 EXTERNAL REF 2.
0118	<b>DI1-3 STATUS</b> Status of the three digital inputs. • Status is displayed as a binary number. • 1 indicates that the input is activated. • 0 indicates that the input is deactivated.
0119	<b>DI4-6 STATUS</b> Status of the three digital inputs. • See parameter 0118 DI1-3 STATUS.
0120	<b>AI1</b> Relative value of analog input 1 in %.

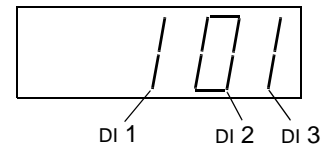

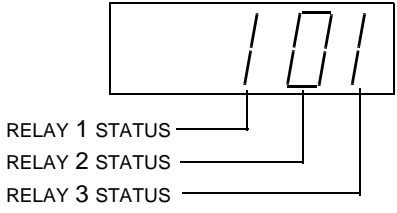
Code	Description
0121	<b>AI2</b> The relative value of analog input 2 in %.
0122	<b>RO1-3 STATUS</b> Status of the three relay outputs. <ul style="list-style-type: none"> <li>• 1 indicates that the relay is energized.</li> <li>• 0 indicates that the relay is de-energized.</li> </ul>
0123	<b>RO4-6 STATUS</b> Status of the three relay outputs. See parameter 0122.
	
0124	<b>AO1</b> The analog output 1 value in milliamperes.
0125	<b>AO2</b> The analog output 2 value in milliamperes.
0126	<b>PID 1 OUTPUT</b> The PID Controller 1 output value in %.
0127	<b>PID 2 OUTPUT</b> The PID Controller 2 output value in %.
0128	<b>PID 1 SETPNT</b> The PID 1 controller setpoint signal. <ul style="list-style-type: none"> <li>• Units and scale defined by PID parameters.</li> </ul>
0129	<b>PID 2 SETPNT</b> The PID 2 controller setpoint signal. <ul style="list-style-type: none"> <li>• Units and scale defined by PID parameters.</li> </ul>
0130	<b>PID 1 FBK</b> The PID 1 controller feedback signal. <ul style="list-style-type: none"> <li>• Units and scale defined by PID parameters.</li> </ul>
0131	<b>PID 2 FBK</b> The PID 2 controller feedback signal. <ul style="list-style-type: none"> <li>• Units and scale defined by PID parameters.</li> </ul>
0132	<b>PID 1 DEVIATION</b> The difference between the PID 1 controller reference value and actual value. <ul style="list-style-type: none"> <li>• Units and scale defined by PID parameters.</li> </ul>
0133	<b>PID 2 DEVIATION</b> The difference between the PID 2 controller reference value and actual value. <ul style="list-style-type: none"> <li>• Units and scale defined by PID parameters.</li> </ul>
0134	<b>COMM RO WORD</b> Free data location that can be written from serial link. <ul style="list-style-type: none"> <li>• Used for relay output control.</li> <li>• See parameter 1401.</li> </ul>
0135	<b>COMM VALUE 1</b> Free data location that can be written from serial link.
0136	<b>COMM VALUE 2</b> Free data location that can be written from serial link.
0137	<b>PROCESS VAR 1</b> Process variable 1 <ul style="list-style-type: none"> <li>• Defined by parameters in Group 34: Panel Display / Process Variables.</li> </ul>
0138	<b>PROCESS VAR 2</b> Process variable 2 <ul style="list-style-type: none"> <li>• Defined by parameters in Group 34: Panel Display / Process Variables.</li> </ul>

Code	Description
0139	<p><b>PROCESS VAR 3</b></p> <p>Process variable 3</p> <ul style="list-style-type: none"> <li>Defined by parameters in Group 34: Panel Display / Process Variables.</li> </ul>
0140	<p><b>RUN TIME</b></p> <p>The drive's accumulated running time in thousands of hours (kh).</p>
0141	<p><b>MWH COUNTER</b></p> <p>The drive's accumulated power consumption in megawatt hours. Can not be reset.</p>
0142	<p><b>REVOLUTION CNTR</b></p> <p>The motor's accumulated revolutions in millions of revolutions.</p>
0143	<p><b>DRIVE ON TIME (HI)</b></p> <p>The drive's accumulated power on time in days.</p>
0144	<p><b>DRIVE ON TIME (LO)</b></p> <p>The drive's accumulated power on time in 2 second ticks (30 ticks = 60 seconds).</p>
0145	<p><b>MOTOR TEMP</b></p> <p>Motor temperature in degrees centigrade / PTC resistance in Ohms.</p> <ul style="list-style-type: none"> <li>Applies only if motor temperature sensor is set up. See parameter 3501.</li> </ul>
0146	<p><b>MECH ANGLE</b></p> <p>Defines the motor shaft's angular position to about 0.01° (32,768 divisions for 360°). The position is defined as 0 at power up.</p> <p>During operation the zero position can be set by:</p> <ul style="list-style-type: none"> <li>A Z-pulse input, if parameter 5010 Z PLS ENABLE = 1 (ENABLE)</li> <li>Parameter 5011 POSITION RESET, if parameter 5010 Z PLS ENABLE = 2 (DISABLE)</li> <li>Any status change of parameter 5002 ENCODER ENABLE</li> </ul>
0147	<p><b>MECH REVS</b></p> <p>A signed integer that counts full revolutions of the motor shaft. The value:</p> <ul style="list-style-type: none"> <li>Increments when parameter 0146 MECH ANGLE changes from 32767 to 0</li> <li>Decrements when parameter 0146 MECH ANGLE changes from 0 to 32767</li> </ul>
0148	<p><b>Z PLS DETECTED</b></p> <p>When a Z-pulse defines the zero position, the shaft must pass through the zero position to trigger a Z-pulse. Until then, the shaft position is unknown (the drive uses the shaft position at power up as zero). This parameter signals when parameter 0146 MECH ANGLE is valid. This parameter starts at zero on power-up and changes to 1 only if:</p> <ul style="list-style-type: none"> <li>Parameter 5010 Z PLS ENABLE = ENABLE and</li> <li>An encoder Z-pulse has been detected.</li> </ul>

### Group 03: FB Actual Signals

This group monitors fieldbus communications.

Code	Description			
0301	<b>FB CMD WORD 1</b> Read-only copy of the Fieldbus Command Word 1. <ul style="list-style-type: none"> <li>The fieldbus command is the principal means for controlling the drive from a fieldbus controller. The command consists of two Command Words. Bit-coded instructions in the Command Words switch the drive between states.</li> <li>To control the drive, using the Command Words, an external location (EXT1 or EXT2) must be active and set to COMM. (See parameters 1001 and 1002.)</li> <li>The control panel displays the word in hex. For example, all zeros and a 1 in Bit 0 displays as 0001. All zeros and a 1 in Bit 15 displays as 8000.</li> </ul>	<b>Bit #</b>	<b>0301, FB CMD WORD 1</b>	<b>0302, FB CMD WORD 2</b>
		0	STOP	Reserved
		1	START	Reserved
		2	REVERSE	Reserved
		3	LOCAL	Reserved
		4	RESET	Reserved
		5	EXT2	Reserved
		6	RUN_DISABLE	Reserved
		7	STPMODE_R	Reserved
		8	STPMODE_EM	Reserved
		9	STPMODE_C	Reserved
		10	RAMP_2	Reserved
		11	RAMP_OUT_0	REF_CONST
		12	RAMP_HOLD	REF_AVE
		13	RAMP_IN_0	LINK_ON
0302	<b>FB CMD WORD 2</b> Read-only copy of the Fieldbus Command Word 2. <ul style="list-style-type: none"> <li>See parameter 0301.</li> </ul>	14	RREQ_LOCALLOC	REQ_STARTINH
		15	TORQLIM2	OFF_INTERLOCK
0303	<b>FB STS WORD 1</b> Read-only copy of the Status Word 1. <ul style="list-style-type: none"> <li>The drive sends status information to the fieldbus controller. The status consists of two Status Words.</li> <li>The control panel displays the word in hex. For example, all zeros and a 1 in Bit 0 displays as 0001. All zeros and a 1 in Bit 15 displays as 8000.</li> </ul>	<b>Bit #</b>	<b>0303, STS CMD WORD 1</b>	<b>0304, FB STS WORD 2</b>
		0	READY	ALARM
		1	ENABLED	REQ_MAINT
		2	STARTED	DIRLOCK
		3	RUNNING	LOCALLOCK
		4	ZERO_SPEED	CTL_MODE
		5	ACCELERATE	Reserved
		6	DECELERATE	Reserved
		7	AT_SETPOINT	Reserved
		8	LIMIT	Reserved
0304	<b>FB STS WORD 2</b> Read-only copy of the Status Word 2. <ul style="list-style-type: none"> <li>See parameter 0303.</li> </ul>	9	SUPERVISION	Reserved
		10	REV_REF	REQ_CTL
		11	REV_ACT	REQ_REF1
		12	PANEL_LOCAL	REQ_REF2
		13	FIELDBUS_LOCAL	REQ_REF2EXT
		14	EXT2_ACT	ACK_STARTINH
		15	FAULT	ACK_OFF_ILCK

<p>0305</p>	<p><b>FAULT WORD 1</b>                  Read-only copy of the Fault Word 1.  <ul style="list-style-type: none"> <li>When a fault is active, the corresponding bit for the active fault is set in the Fault Words.</li> <li>Each fault has a dedicated bit allocated within Fault Words.</li> <li>See "Fault Listing" on page 202 for a description of the faults.</li> <li>The control panel displays the word in hex. For example, all zeros and a 1 in Bit 0 displays as 0001. All zeros and a 1 in Bit 15 displays as 8000.</li> </ul> </p>	<table border="1"> <thead> <tr> <th>Bit #</th> <th>0305, FAULT WORD 1</th> <th>0306, FAULT WORD 2</th> <th>0307, FAULT WORD 3</th> </tr> </thead> <tbody> <tr><td>0</td><td>OVERCURRENT</td><td>UNDERLOAD</td><td>EFB 1</td></tr> <tr><td>1</td><td>DC OVERVOLT</td><td>THERM FAIL</td><td>EFB 2</td></tr> <tr><td>2</td><td>DEV OVERTEMP</td><td>OPEX LINK</td><td>EFB 3</td></tr> <tr><td>3</td><td>SHORT CIRC</td><td>OPEX PWR</td><td>Incompatible software type</td></tr> <tr><td>4</td><td>Reserved</td><td>CURR MEAS</td><td>Reserved</td></tr> <tr><td>5</td><td>DC UNDERVOLT</td><td>SUPPLY PHASE</td><td>Reserved</td></tr> <tr><td>6</td><td>AI1 LOSS</td><td>ENCODER ERROR</td><td>Reserved</td></tr> <tr><td>7</td><td>AI2 LOSS</td><td>OVERSPEED</td><td>Reserved</td></tr> <tr><td>8</td><td>MOT OVERTEMP</td><td>Reserved</td><td>Reserved</td></tr> <tr><td>9</td><td>PANEL LOSS</td><td>DRIVE ID</td><td>Reserved</td></tr> <tr><td>10</td><td>ID RUN FAIL</td><td>CONFIG FILE</td><td>System error</td></tr> <tr><td>11</td><td>MOTOR STALL</td><td>SERIAL 1 ERR</td><td>System error</td></tr> <tr><td>12</td><td>Reserved</td><td>EFB CON FILE</td><td>System error</td></tr> <tr><td>13</td><td>EXT FLT 1</td><td>FORCE TRIP</td><td>System error</td></tr> <tr><td>14</td><td>EXT FLT 2</td><td>MOTOR PHASE</td><td>Hardware error</td></tr> <tr><td>15</td><td>EARTH FAULT</td><td>OUTPUT WIRING</td><td>Param. setting fault</td></tr> </tbody> </table>			Bit #	0305, FAULT WORD 1	0306, FAULT WORD 2	0307, FAULT WORD 3	0	OVERCURRENT	UNDERLOAD	EFB 1	1	DC OVERVOLT	THERM FAIL	EFB 2	2	DEV OVERTEMP	OPEX LINK	EFB 3	3	SHORT CIRC	OPEX PWR	Incompatible software type	4	Reserved	CURR MEAS	Reserved	5	DC UNDERVOLT	SUPPLY PHASE	Reserved	6	AI1 LOSS	ENCODER ERROR	Reserved	7	AI2 LOSS	OVERSPEED	Reserved	8	MOT OVERTEMP	Reserved	Reserved	9	PANEL LOSS	DRIVE ID	Reserved	10	ID RUN FAIL	CONFIG FILE	System error	11	MOTOR STALL	SERIAL 1 ERR	System error	12	Reserved	EFB CON FILE	System error	13	EXT FLT 1	FORCE TRIP	System error	14	EXT FLT 2	MOTOR PHASE	Hardware error	15	EARTH FAULT	OUTPUT WIRING	Param. setting fault
Bit #	0305, FAULT WORD 1	0306, FAULT WORD 2	0307, FAULT WORD 3																																																																					
0	OVERCURRENT	UNDERLOAD	EFB 1																																																																					
1	DC OVERVOLT	THERM FAIL	EFB 2																																																																					
2	DEV OVERTEMP	OPEX LINK	EFB 3																																																																					
3	SHORT CIRC	OPEX PWR	Incompatible software type																																																																					
4	Reserved	CURR MEAS	Reserved																																																																					
5	DC UNDERVOLT	SUPPLY PHASE	Reserved																																																																					
6	AI1 LOSS	ENCODER ERROR	Reserved																																																																					
7	AI2 LOSS	OVERSPEED	Reserved																																																																					
8	MOT OVERTEMP	Reserved	Reserved																																																																					
9	PANEL LOSS	DRIVE ID	Reserved																																																																					
10	ID RUN FAIL	CONFIG FILE	System error																																																																					
11	MOTOR STALL	SERIAL 1 ERR	System error																																																																					
12	Reserved	EFB CON FILE	System error																																																																					
13	EXT FLT 1	FORCE TRIP	System error																																																																					
14	EXT FLT 2	MOTOR PHASE	Hardware error																																																																					
15	EARTH FAULT	OUTPUT WIRING	Param. setting fault																																																																					
<p>0306</p>	<p><b>FAULT WORD 2</b>                  Read-only copy of the Fault Word 2.  <ul style="list-style-type: none"> <li>See parameter 0305.</li> </ul> </p>																																																																							
<p>0307</p>	<p><b>FAULT WORD 3</b>                  Read-only copy of the Fault Word 3.  <ul style="list-style-type: none"> <li>See parameter 0305.</li> </ul> </p>																																																																							
<p>0308</p>	<p><b>ALARM WORD 1</b>  <ul style="list-style-type: none"> <li>When an alarm is active, the corresponding bit for the active alarm is set in the Alarm Words.</li> <li>Each alarm has a dedicated bit allocated within Alarm Words.</li> <li>Bits remain set until the whole alarm word is reset. (Reset by writing zero to the word.)</li> <li>The control panel displays the word in hex. For example, all zeros and a 1 in Bit 0 displays as 0001. All zeros and a 1 in Bit 15 displays as 8000.</li> </ul> </p>	<table border="1"> <thead> <tr> <th>Bit #</th> <th>0308, ALARM WORD 1</th> <th>0309, ALARM WORD 2</th> </tr> </thead> <tbody> <tr><td>0</td><td>OVERCURRENT</td><td>Reserved</td></tr> <tr><td>1</td><td>OVERVOLTAGE</td><td>PID SLEEP</td></tr> <tr><td>2</td><td>UNDERVOLTAGE</td><td>ID RUN</td></tr> <tr><td>3</td><td>DIRLOCK</td><td>Reserved</td></tr> <tr><td>4</td><td>I/O COMM</td><td>START ENABLE 1 MISSING</td></tr> <tr><td>5</td><td>AI1 LOSS</td><td>START ENABLE 2 MISSING</td></tr> <tr><td>6</td><td>AI2 LOSS</td><td>EMERGENCY STOP</td></tr> <tr><td>7</td><td>PANEL LOSS</td><td>ENCODER ERROR</td></tr> <tr><td>8</td><td>DEVICE OVERTEMP</td><td>FIRST START</td></tr> <tr><td>9</td><td>MOT OVERTEMP</td><td>Reserved</td></tr> <tr><td>10</td><td>UNDERLOAD</td><td>Reserved</td></tr> <tr><td>11</td><td>MOTOR STALL</td><td>Reserved</td></tr> <tr><td>12</td><td>AUTORESET</td><td>Reserved</td></tr> <tr><td>13</td><td>PFC AUTOCHANGE</td><td>Reserved</td></tr> <tr><td>14</td><td>PFC INTERLOCK</td><td>Reserved</td></tr> <tr><td>15</td><td>Reserved</td><td>Reserved</td></tr> </tbody> </table>			Bit #	0308, ALARM WORD 1	0309, ALARM WORD 2	0	OVERCURRENT	Reserved	1	OVERVOLTAGE	PID SLEEP	2	UNDERVOLTAGE	ID RUN	3	DIRLOCK	Reserved	4	I/O COMM	START ENABLE 1 MISSING	5	AI1 LOSS	START ENABLE 2 MISSING	6	AI2 LOSS	EMERGENCY STOP	7	PANEL LOSS	ENCODER ERROR	8	DEVICE OVERTEMP	FIRST START	9	MOT OVERTEMP	Reserved	10	UNDERLOAD	Reserved	11	MOTOR STALL	Reserved	12	AUTORESET	Reserved	13	PFC AUTOCHANGE	Reserved	14	PFC INTERLOCK	Reserved	15	Reserved	Reserved																	
Bit #	0308, ALARM WORD 1	0309, ALARM WORD 2																																																																						
0	OVERCURRENT	Reserved																																																																						
1	OVERVOLTAGE	PID SLEEP																																																																						
2	UNDERVOLTAGE	ID RUN																																																																						
3	DIRLOCK	Reserved																																																																						
4	I/O COMM	START ENABLE 1 MISSING																																																																						
5	AI1 LOSS	START ENABLE 2 MISSING																																																																						
6	AI2 LOSS	EMERGENCY STOP																																																																						
7	PANEL LOSS	ENCODER ERROR																																																																						
8	DEVICE OVERTEMP	FIRST START																																																																						
9	MOT OVERTEMP	Reserved																																																																						
10	UNDERLOAD	Reserved																																																																						
11	MOTOR STALL	Reserved																																																																						
12	AUTORESET	Reserved																																																																						
13	PFC AUTOCHANGE	Reserved																																																																						
14	PFC INTERLOCK	Reserved																																																																						
15	Reserved	Reserved																																																																						
<p>0309</p>	<p><b>ALARM WORD 2</b>                  See parameter 0308.</p>																																																																							

### Group 04: Fault History

This group stores a recent history of the faults reported by the drive.

Code	Description
0401	<b>LAST FAULT</b> 0 = Clear the fault history (on panel = NO RECORD). n = Fault code of the last recorded fault.
0402	<b>FAULT TIME 1</b> The day on which the last fault occurred. Either as: <ul style="list-style-type: none"> <li>• A date – if real time clock is operating.</li> <li>• The number of days after power on – if real time clock is not used, or was not set.</li> </ul>
0403	<b>FAULT TIME 2</b> The time at which the last fault occurred. Either as: <ul style="list-style-type: none"> <li>• Real time, in format hh:mm:ss – if real time clock is operating.</li> <li>• The time since power on (less the whole days reported in 0402), in format hh:mm:ss – if real time clock is not used, or was not set.</li> </ul>
0404	<b>SPEED AT FLT</b> The motor speed (rpm) at the time the last fault occurred.
0405	<b>FREQ AT FLT</b> The frequency (Hz) at the time the last fault occurred.
0406	<b>VOLTAGE AT FLT</b> The DC bus voltage (V) at the time the last fault occurred.
0407	<b>CURRENT AT FLT</b> The motor current (A) at the time the last fault occurred.
0408	<b>TORQUE AT FLT</b> The motor torque (%) at the time the last fault occurred.
0409	<b>STATUS AT FLT</b> The drive status (hex code word) at the time the last fault occurred.
0410	<b>DI 1-3 AT FLT</b> The status of digital inputs 1...3 at the time the last fault occurred.
0411	<b>DI 4-6 AT FLT</b> The status of digital inputs 4...6 at the time the last fault occurred.
0412	<b>PREVIOUS FAULT 1</b> Fault code of the second last fault. Read-only.
0413	<b>PREVIOUS FAULT 2</b> Fault code of the third last fault. Read-only.



## Group 10: Start/Stop/Dir

This group:

- Defines external sources (EXT1, and EXT2) for commands that enable start, stop and direction changes.
- Locks direction or enables direction control.

To select between the two external locations use the next group (parameter 1102).

Code	Description
1001	<p><b>EXT1 COMMANDS</b></p> <p>Defines external control location 1 (EXT1) – the configuration of start, stop and direction commands.</p> <p>0 = NOT SEL – No external start, stop and direction command source.</p> <p>1 = DI1 – Two-wire Start/Stop.</p> <ul style="list-style-type: none"> <li>• Start/Stop is through digital input DI1 (DI1 activated = Start; DI1 de-activated = Stop).</li> <li>• Parameter 1003 defines the direction. Selecting 1003 = 3 (REQUEST) is the same as 1003 = 1 (FWD).</li> </ul> <p>2 = DI1, 2 – Two-wire Start/Stop, Direction.</p> <ul style="list-style-type: none"> <li>• Start/Stop is through digital input DI1 (DI1 activated = Start; DI1 de-activated = Stop).</li> <li>• Direction control (requires parameter 1003 = 3 (REQUEST)) is through digital input DI2 (DI2 activated = Reverse; de-activated = Forward).</li> </ul> <p>3 = DI1P, 2P – Three-wire Start/Stop.</p> <ul style="list-style-type: none"> <li>• Start/Stop commands are through momentary push-buttons (the P stands for “pulse”).</li> <li>• Start is through a normally open push-button connected to digital input DI1. In order to start the drive, the digital input DI2 must be activated prior to the pulse in DI1.</li> <li>• Connect multiple Start push-buttons in parallel.</li> <li>• Stop is through a normally closed push-button connected to digital input DI2.</li> <li>• Connect multiple Stop push-buttons in series.</li> <li>• Parameter 1003 defines the direction. Selecting 1003 = 3 (REQUEST) is the same as 1003 = 1 (FWD).</li> </ul> <p>4 = DI1P, 2P, 3 – Three-wire Start/Stop, Direction.</p> <ul style="list-style-type: none"> <li>• Start/Stop commands are through momentary push-buttons, as described for DI1P, 2P.</li> <li>• Direction control (requires parameter 1003 = 3 (REQUEST)) is through digital input DI3 (DI3 activated = Reverse; de-activated = Forward).</li> </ul> <p>5 = DI1P, 2P, 3P – Start Forward, Start Reverse, and Stop.</p> <ul style="list-style-type: none"> <li>• Start and Direction commands are given simultaneously with two separate momentary push-buttons (the P stands for “pulse”).</li> <li>• Start Forward command is through a normally open push-button connected to digital input DI1. In order to start the drive, the digital input DI3 must be activated prior to the pulse in DI1.</li> <li>• Start Reverse command is through a normally open push-button connected to digital input DI2. In order to start the drive, the digital input DI3 must be activated during the pulse in DI2.</li> <li>• Connect multiple Start push-buttons in parallel.</li> <li>• Stop is through a normally closed push-button connected to digital input DI3.</li> <li>• Connect multiple Stop push-buttons in series.</li> <li>• Requires parameter 1003 = 3 (REQUEST).</li> </ul> <p>6 = DI6 – Two-wire Start/Stop.</p> <ul style="list-style-type: none"> <li>• Start/Stop is through digital input DI6 (DI6 activated = Start; DI6 de-activated = Stop).</li> <li>• Parameter 1003 defines the direction. Selecting 1003 = 3 (REQUEST) is the same as 1003 = 1 (FWD).</li> </ul> <p>7 = DI6, 5 – Two-wire Start/Stop/Direction.</p> <ul style="list-style-type: none"> <li>• Start/Stop is through digital input DI6 (DI6 activated = Start; DI6 de-activated = Stop).</li> <li>• Direction control (requires parameter 1003 = 3 (REQUEST)) is through digital input DI5. (DI5 activated = Reverse; de-activated = Forward).</li> </ul> <p>8 = KEYPAD – Control Panel.</p> <ul style="list-style-type: none"> <li>• Start/Stop and Direction commands are through the control panel when EXT1 is active.</li> <li>• Direction control requires parameter 1003 = 3 (REQUEST).</li> </ul> <p>9 = DI1F, 2R – Start/Stop/Direction commands through DI1 and DI2 combinations.</p> <ul style="list-style-type: none"> <li>• Start forward = DI1 activated and DI2 de-activated.</li> <li>• Start reverse = DI1 de-activated and DI2 activated.</li> <li>• Stop = both DI1 and DI2 activated, or both de-activated.</li> <li>• Requires parameter 1003 = 3 (REQUEST).</li> </ul> <p>10 = COMM – Assigns the fieldbus Command Word as the source for the start/stop and direction commands.</p> <ul style="list-style-type: none"> <li>• Bits 0,1, 2 of Command Word 1 (parameter 0301) activates the start/stop and direction commands.</li> <li>• See Fieldbus user's manual for detailed instructions.</li> </ul>

Code	Description
	11 = TIMER FUNCTION 1. – Assigns Start/Stop control to Timer Function 1 (Timer Function activated = START; Timer Function de-activated = STOP). See Group 36, Timer Functions. 12...14 = TIMER FUNCTION 2... 4 – Assigns Start/Stop control to Timer Function 2...4. See Timer Function 1 above.
1002	<b>EXT2 COMMANDS</b> Defines external control location 2 (EXT2) – the configuration of start, stop and direction commands. • See parameter 1001 EXT1 COMMANDS above.
1003	<b>DIRECTION</b> Defines the control of motor rotation direction. 1 = FORWARD – Rotation is fixed in the forward direction. 2 = REVERSE – Rotation is fixed in the reverse direction. 3 = REQUEST – Rotation direction can be changed on command.

### Group 11: Reference Select

This group defines:

- How the drive selects between command sources.
- Characteristics and sources for REF1 and REF2.

Code	Description
1101	<p><b>KEYPAD REF SEL</b></p> <p>Selects the reference controlled in local control mode.</p> <p>1 = REF1 (Hz/rpm) – Reference type depends on parameter 9904 MOTOR CTRL MODE.</p> <ul style="list-style-type: none"> <li>• Speed reference (rpm) if 9904 = 1 (VECTOR: SPEED) or 2 (VECTOR: TORQ).</li> <li>• Frequency reference (Hz) if 9904 = 3 (SCALAR: SPEED).</li> </ul> <p>2 = REF2 (%)</p>
1102	<p><b>EXT1/EXT2 SEL</b></p> <p>Defines the source for selecting between the two external control locations EXT1 or EXT2. Thus, defines the source for Start/Stop/Direction commands and reference signals.</p> <p>0 = EXT1 – Selects external control location 1 (EXT1).</p> <ul style="list-style-type: none"> <li>• See parameter 1001 EXT1 COMMANDS for EXT1's Start/Stop/Dir definitions.</li> <li>• See parameter 1103 REF1 SELECT for EXT1's reference definitions.</li> </ul> <p>1 = DI1 – Assigns control to EXT1 or EXT2 based on the state of DI1 (DI1 activated = EXT2; DI1 de-activated = EXT1).</p> <p>2...6 = DI2...DI6 – Assigns control to EXT1 or EXT2 based on the state of the selected digital input. See DI1 above.</p> <p>7 = EXT2 – Selects external control location 2 (EXT2).</p> <ul style="list-style-type: none"> <li>• See parameter 1002 EXT2 COMMANDS for EXT2's Start/Stop/Dir definitions.</li> <li>• See parameter 1106 REF2 SELECT for EXT2's reference definitions.</li> </ul> <p>8 = COMM – Assigns control of the drive via external control location EXT1 or EXT2 based on the fieldbus control word.</p> <ul style="list-style-type: none"> <li>• Bit 5 of the Command Word 1 (parameter 0301) defines the active external control location (EXT1 or EXT2).</li> <li>• See Fieldbus user's manual for detailed instructions.</li> </ul> <p>9 = TIMER FUNCTION 1 – Assigns control to EXT1 or EXT2 based on the state of the Timer Function (Timer Function activated = EXT2; Timer Function de-activated = EXT1). See Group 36, Timer Functions.</p> <p>10...12 = TIMER FUNCTION 2...4 – Assigns control to EXT1 or EXT2 based on the state of the Timer Function. See Timer Function 1 above.</p> <p>-1 = DI1(INV) – Assigns control to EXT1 or EXT2 based on the state of DI1 (DI1 activated = EXT1; DI1 de-activated = EXT2).</p> <p>-2...-6 = DI2(INV)...DI6(INV) – Assigns control to EXT1 or EXT2 based on the state of the selected digital input. See DI1(INV) above.</p>
1103	<p><b>REF1 SELECT</b></p> <p>Selects the signal source for external reference REF1.</p> <p>0 = KEYPAD – Defines the control panel as the reference source.</p> <p>1 = AI1 – Defines analog input 1 (AI1) as the reference source.</p> <p>2 = AI2 – Defines analog input 2 (AI2) as the reference source.</p> <p>3 = AI1/JOYST – Defines analog input 1 (AI1), configured for joystick operation, as the reference source.</p> <ul style="list-style-type: none"> <li>• The minimum input signal runs the drive at the maximum reference in the reverse direction. Define the minimum using parameter 1104.</li> <li>• The maximum input signal runs the drive at maximum reference in the forward direction. Define the maximum using parameter 1105.</li> <li>• Requires parameter 1003=3 (REQUEST).</li> </ul> <p><b>Warning! Because the low end of the reference range commands full reverse operation, do not use 0 V as the lower end of the reference range. Doing so means that if the control signal is lost (which is a 0 V input) the result is full reverse operation. Instead, use the following set-up so that loss of the analog input triggers a fault, stopping the drive:</b></p> <ul style="list-style-type: none"> <li>• Set parameter 1301 MINIMUM AI1 (1304 MINIMUM AI2) at 20% (2 V or 4 mA).</li> <li>• Set parameter 3021 AI1 FAULT LIMIT to a value 5% or higher.</li> <li>• Set parameter 3001 AI&lt;MIN FUNCTION to 1 (FAULT).</li> </ul> <p>4 = AI2/JOYST – Defines analog input 2 (AI2), configured for joystick operation, as the reference source.</p> <ul style="list-style-type: none"> <li>• See above (AI1/JOYST) description.</li> </ul>

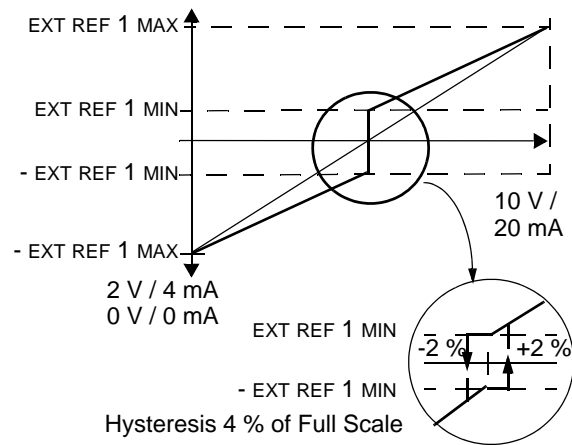

- 5 = DI3U,4D(R) – Defines digital inputs as the speed reference source (motor potentiometer control).
  - Digital input DI3 increases the speed (the U stands for “up”).
  - Digital input DI4 decreases the speed (the D stands for “down”).
  - A Stop command resets the reference to zero (the R stands for “reset”).
  - Parameter 2205 ACCELER TIME 2 controls the reference signal's rate of change.
- 6 = DI3U,4D – Same as above (DI3U,4D(R)), except:
  - A Stop command does not reset the reference to zero. The reference is stored.
  - When the drive restarts, the motor ramps up (at the selected acceleration rate) to the stored reference.
- 7 = DI5U,6D – Same as above (DI3U,4D), except that DI5 and DI6 are the digital inputs used.
- 8 = COMM – Defines the fieldbus as the reference source.
- 9 = COMM+AI1 – Defines a fieldbus and analog input 1 (AI1) combination as the reference source. See Analog Input Reference Correction below.
- 10 = COMM\*AI1 – Defines a fieldbus and analog input 1 (AI1) combination as the reference source. See Analog Input Reference Correction below.
- 11 = DI3U, 4D(RNC) – Same as DI3U,4D(R) above, except that:
  - Changing the control source (EXT1 to EXT2, EXT2 to EXT1, LOC to REM) does not copy the reference.
- 12 = DI3U,4D(NC) – Same as DI3U,4D above, except that:
  - Changing the control source (EXT1 to EXT2, EXT2 to EXT1, LOC to REM) does not copy the reference.
- 13 = DI5U,6D(NC) – Same as DI5U,6D above, except that:
  - Changing the control source (EXT1 to EXT2, EXT2 to EXT1, LOC to REM) does not copy the reference.
- 14 = AI1+AI2 – Defines an analog input 1 (AI1) and analog input 2 (AI2) combination as the reference source. See Analog Input Reference Correction below.
- 15 = AI1\*AI2 – Defines an analog input 1 (AI1) and analog input 2 (AI2) combination as the reference source. See Analog Input Reference Correction below.
- 16 = AI1-AI2 – Defines an analog input 1 (AI1) and analog input 2 (AI2) combination as the reference source. See Analog Input Reference Correction below.
- 17 = AI1/AI2 – Defines an analog input 1 (AI1) and analog input 2 (AI2) combination as the reference source. See Analog Input Reference Correction below.

**Analog Input Reference Correction**

Parameter values 9, 10, and 14...17 use the formula in the following table.

Value Setting	AI reference is calculated as following:
C + B	C value + (B value - 50% of reference value)
C * B	C value * (B value / 50% of reference value)
C - B	(C value + 50% of reference value) - B value
C / B	(C value * 50% of reference value) / B value

Where:

- C = Main Reference value  
(= COMM for values 9, 10 and = AI1 for values 14...17).
- B = Correcting reference  
(= AI1 for values 9, 10 and = AI2 for values 14...17).

**Example:**

The figure shows the reference source curves for value settings 9, 10, and 14...17, where:

- C = 25%.
- P 4012 SETPOINT MIN = 0.
- P 4013 SETPOINT MAX = 0.
- B varies along the horizontal axis.

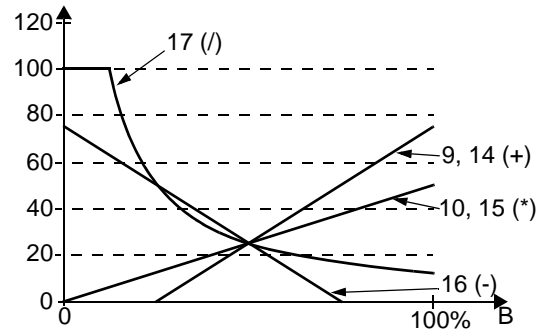

<p>1104</p>	<p><b>REF1 MIN</b> Sets the minimum for external reference 1.</p> <ul style="list-style-type: none"> <li>• The minimum analog input signal (as a percent of the full signal in volts or amps) corresponds to REF1 MIN in Hz/rpm.</li> <li>• Parameter 1301 MINIMUM AI1 or 1304 MINIMUM AI2 sets the minimum analog input signal.</li> <li>• These parameters (reference and analog min. and max. settings) provide scale and offset adjustment for the reference.</li> </ul>	
<p>1105</p>	<p><b>REF1 MAX</b> Sets the maximum for external reference 1.</p> <ul style="list-style-type: none"> <li>• The maximum analog input signal (as a percent of full the signal in volts or amps) corresponds to REF1 MAX in Hz/rpm.</li> <li>• Parameter 1302 MAXIMUM AI1 or 1305 MAXIMUM AI2 sets the maximum analog input signal.</li> </ul>	
<p>1106</p>	<p><b>REF2 SELECT</b> Selects the signal source for external reference REF2. 0...17 – Same as for parameter 1103 REF1 SELECT. 19 = PID1OUT – The reference is taken from the PID1 output. See Groups 40 and 41.</p>	
<p>1107</p>	<p><b>REF2 MIN</b> Sets the minimum for external reference 2.</p> <ul style="list-style-type: none"> <li>• The minimum analog input signal (in volts or amps) corresponds to REF2 MIN in %.</li> <li>• Parameter 1301 MINIMUM AI1 or 1304 MINIMUM AI2 sets the minimum analog input signal.</li> <li>• This parameter sets the minimum frequency reference.</li> <li>• The value is a percentage of the: <ul style="list-style-type: none"> <li>– maximum frequency or speed.</li> <li>– maximum process reference</li> <li>– nominal torque</li> </ul> </li> </ul>	
<p>1108</p>	<p><b>REF2 MAX</b> Sets the maximum for external reference 2.</p> <ul style="list-style-type: none"> <li>• The maximum analog input signal (in volts or amps) corresponds to REF2 MAX in Hz.</li> <li>• Parameter 1302 MAXIMUM AI1 or 1305 MAXIMUM AI2 sets the maximum analog input signal.</li> <li>• This parameter sets the maximum frequency reference.</li> <li>• The value is a percentage of the: <ul style="list-style-type: none"> <li>– maximum frequency or speed</li> <li>– maximum process reference</li> <li>– nominal torque</li> </ul> </li> </ul>	

## Group 12: Constant Speeds

This group defines a set of constant speeds. In general:

- You can program up to 7 constant speeds, ranging from 0...500 Hz or 0...30000 rpm.
- Values must be positive (No negative speed values for constant speeds).
- Constant speed selections are ignored if:
  - the torque control is active, or
  - the process PID reference is followed, or
  - the drive is in local control mode, or
  - PFC (Pump-Fan Control) is active.

**Note!** Parameter 1208 CONST SPEED 7 acts also as a so-called fault speed which may be activated if the control signal is lost. For example, see parameters 3001 AI<MIN FUNCTION, 3002 PANEL COMM ERROR and 3018 COMM FAULT FUNC.

Code	Description																																																			
1201	<p><b>CONST SPEED SEL</b>            Defines the digital inputs used to select Constant Speeds. See general comments in introduction.            0 = NOT SEL – Disables the constant speed function.            1 = DI1 – Selects Constant Speed 1 with digital input DI1.            • Digital input activated = Constant Speed 1 activated.            2...6 = DI2...DI6 – Selects Constant Speed 1 with digital input DI2...DI6. See above.            7 = DI1,2 – Selects one of three Constant Speeds (1...3) using DI1 and DI2.            • Uses two digital inputs, as defined below (0 = DI de-activated, 1 = DI activated):</p> <table border="1"> <thead> <tr> <th>DI1</th> <th>DI2</th> <th>Function</th> </tr> </thead> <tbody> <tr> <td>0</td> <td>0</td> <td>No constant speed</td> </tr> <tr> <td>1</td> <td>0</td> <td>Constant speed 1 (1202)</td> </tr> <tr> <td>0</td> <td>1</td> <td>Constant speed 2 (1203)</td> </tr> <tr> <td>1</td> <td>1</td> <td>Constant speed 3 (1204)</td> </tr> </tbody> </table> <p>• Can be set up as a so-called fault speed, which is activated if the control signal is lost. Refer to parameter 3001 AI&lt;MIN function and parameter 3002 PANEL COMM ERR.            8 = DI2,3 – Selects one of three Constant Speeds (1...3) using DI2 and DI3.            • See above (DI1,2) for code.            9 = DI3,4 – Selects one of three Constant Speeds (1...3) using DI3 and DI4.            • See above (DI1,2) for code.            10 = DI4,5 – Selects one of three Constant Speeds (1...3) using DI4 and DI5.            • See above (DI1,2) for code.            11 = DI5,6 – Selects one of three Constant Speeds (1...3) using DI5 and DI6.            • See above (DI1,2) for code.            12 = DI1,2,3 – Selects one of seven Constant Speeds (1...7) using DI1, DI2 and DI3.            • Uses three digital inputs, as defined below (0 = DI de-activated, 1 = DI activated):</p> <table border="1"> <thead> <tr> <th>DI1</th> <th>DI2</th> <th>DI3</th> <th>Function</th> </tr> </thead> <tbody> <tr> <td>0</td> <td>0</td> <td>0</td> <td>No constant speed</td> </tr> <tr> <td>1</td> <td>0</td> <td>0</td> <td>Constant speed 1 (1202)</td> </tr> <tr> <td>0</td> <td>1</td> <td>0</td> <td>Constant speed 2 (1203)</td> </tr> <tr> <td>1</td> <td>1</td> <td>0</td> <td>Constant speed 3 (1204)</td> </tr> <tr> <td>0</td> <td>0</td> <td>1</td> <td>Constant speed 4 (1205)</td> </tr> <tr> <td>1</td> <td>0</td> <td>1</td> <td>Constant speed 5 (1206)</td> </tr> <tr> <td>0</td> <td>1</td> <td>1</td> <td>Constant speed 6 (1207)</td> </tr> <tr> <td>1</td> <td>1</td> <td>1</td> <td>Constant speed 7 (1208)</td> </tr> </tbody> </table>	DI1	DI2	Function	0	0	No constant speed	1	0	Constant speed 1 (1202)	0	1	Constant speed 2 (1203)	1	1	Constant speed 3 (1204)	DI1	DI2	DI3	Function	0	0	0	No constant speed	1	0	0	Constant speed 1 (1202)	0	1	0	Constant speed 2 (1203)	1	1	0	Constant speed 3 (1204)	0	0	1	Constant speed 4 (1205)	1	0	1	Constant speed 5 (1206)	0	1	1	Constant speed 6 (1207)	1	1	1	Constant speed 7 (1208)
DI1	DI2	Function																																																		
0	0	No constant speed																																																		
1	0	Constant speed 1 (1202)																																																		
0	1	Constant speed 2 (1203)																																																		
1	1	Constant speed 3 (1204)																																																		
DI1	DI2	DI3	Function																																																	
0	0	0	No constant speed																																																	
1	0	0	Constant speed 1 (1202)																																																	
0	1	0	Constant speed 2 (1203)																																																	
1	1	0	Constant speed 3 (1204)																																																	
0	0	1	Constant speed 4 (1205)																																																	
1	0	1	Constant speed 5 (1206)																																																	
0	1	1	Constant speed 6 (1207)																																																	
1	1	1	Constant speed 7 (1208)																																																	

Code	Description																																																			
	<p>13 = DI3,4,5 – Selects one of seven Constant Speeds (1...7) using DI3, DI4 and DI5.                      • See above (DI1,2,3) for code.</p> <p>14 = DI4,5,6 – Selects one of seven Constant Speeds (1...7) using DI5, DI6 and DI7.                      • See above (DI1,2,3) for code.</p> <p>15...18 = TIMER FUNCTION 1...4 – Selects Constant speed 1 when Timer Function is active. See Group 36, Timer Functions.</p> <p>19 = TIMER 1 &amp; 2 – Selects a constant depending on the state of Timers 1 &amp; 2. See parameter 1209.</p> <p>-1 = DI1(INV) – Selects Constant Speed 1 with digital input DI1.                      • Inverse operation: Digital input de-activated = Constant Speed 1 activated.</p> <p>-2...-6 = DI2(INV)...DI6(INV) – Selects Constant Speed 1 with digital input. See above.</p> <p>-7 = DI1,2(INV) – Selects one of three Constant Speeds (1...3) using DI1 and DI2.                      • Inverse operation uses two digital inputs, as defined below (0 = DI de-activated, 1 = DI activated):</p> <table border="1" style="margin-left: 20px;"> <thead> <tr> <th>DI1</th> <th>DI2</th> <th>Function</th> </tr> </thead> <tbody> <tr> <td>1</td> <td>1</td> <td>No constant speed</td> </tr> <tr> <td>0</td> <td>1</td> <td>Constant speed 1 (1202)</td> </tr> <tr> <td>1</td> <td>0</td> <td>Constant speed 2 (1203)</td> </tr> <tr> <td>0</td> <td>0</td> <td>Constant speed 3 (1204)</td> </tr> </tbody> </table> <p>-8 = DI2,3(INV) – Selects one of three Constant Speeds (1...3) using DI2 and DI2.                      • See above (DI1,2(INV)) for code.</p> <p>-9 = DI3,4(INV) – Selects one of three Constant Speeds (1...3) using DI3 and DI4.                      • See above (DI1,2(INV)) for code.</p> <p>-10 = DI4,5(INV) – Selects one of three Constant Speeds (1...3) using DI4 and DI5.                      • See above (DI1,2(INV)) for code.</p> <p>-11 = DI5,6(INV) – Selects one of three Constant Speeds (1...3) using DI5 and DI6.                      • See above (DI1,2(INV)) for code.</p> <p>-12 = DI1,2,3(INV) – Selects one of seven Constant Speeds (1...3) using DI1, DI2 and DI3.                      • Inverse operation uses three digital inputs, as defined below (0 = DI de-activated, 1 = DI activated):</p> <table border="1" style="margin-left: 20px;"> <thead> <tr> <th>DI1</th> <th>DI2</th> <th>DI3</th> <th>Function</th> </tr> </thead> <tbody> <tr> <td>1</td> <td>1</td> <td>1</td> <td>No constant speed</td> </tr> <tr> <td>0</td> <td>1</td> <td>1</td> <td>Constant speed 1 (1202)</td> </tr> <tr> <td>1</td> <td>0</td> <td>1</td> <td>Constant speed 2 (1203)</td> </tr> <tr> <td>0</td> <td>0</td> <td>1</td> <td>Constant speed 3 (1204)</td> </tr> <tr> <td>1</td> <td>1</td> <td>0</td> <td>Constant speed 4 (1205)</td> </tr> <tr> <td>0</td> <td>1</td> <td>0</td> <td>Constant speed 5 (1206)</td> </tr> <tr> <td>1</td> <td>0</td> <td>0</td> <td>Constant speed 6 (1207)</td> </tr> <tr> <td>0</td> <td>0</td> <td>0</td> <td>Constant speed 7 (1208)</td> </tr> </tbody> </table> <p>-13 = DI3,4,5(INV) – Selects one of seven Constant Speeds (1...3) using DI3, DI4 and DI5.                      • See above (DI1,2,3(INV)) for code.</p> <p>-14 = DI4,5,6(INV) – Selects one of seven Constant Speeds (1...3) using DI4, DI5 and DI6.                      • See above (DI1,2,3(INV)) for code.</p>	DI1	DI2	Function	1	1	No constant speed	0	1	Constant speed 1 (1202)	1	0	Constant speed 2 (1203)	0	0	Constant speed 3 (1204)	DI1	DI2	DI3	Function	1	1	1	No constant speed	0	1	1	Constant speed 1 (1202)	1	0	1	Constant speed 2 (1203)	0	0	1	Constant speed 3 (1204)	1	1	0	Constant speed 4 (1205)	0	1	0	Constant speed 5 (1206)	1	0	0	Constant speed 6 (1207)	0	0	0	Constant speed 7 (1208)
DI1	DI2	Function																																																		
1	1	No constant speed																																																		
0	1	Constant speed 1 (1202)																																																		
1	0	Constant speed 2 (1203)																																																		
0	0	Constant speed 3 (1204)																																																		
DI1	DI2	DI3	Function																																																	
1	1	1	No constant speed																																																	
0	1	1	Constant speed 1 (1202)																																																	
1	0	1	Constant speed 2 (1203)																																																	
0	0	1	Constant speed 3 (1204)																																																	
1	1	0	Constant speed 4 (1205)																																																	
0	1	0	Constant speed 5 (1206)																																																	
1	0	0	Constant speed 6 (1207)																																																	
0	0	0	Constant speed 7 (1208)																																																	
1202	<p><b>CONST SPEED 1</b>                      Sets value for Constant Speed 1.                      • The range and units depend on parameter 9904 MOTOR CTRL MODE.                      • Range: 0...30000 rpm when 9904 = 1 (VECTOR: SPEED) or 2 (VECTOR: TORQ).                      • Range: 0...500 Hz when 9904 = 3 (SCALAR: SPEED).</p>																																																			
1203 ... 1208	<p><b>CONST SPEED 2...CONST SPEED 7</b>                      Each sets a value for a Constant Speed. See CONST SPEED 1 above.</p>																																																			

Code	Description																														
1209	<p><b>TIMED MODE SEL</b></p> <p>Defines timer activated, constant speed mode. Timer can be used to change between external reference and a maximum of three constant speeds, or to change between a maximum of 4 selectable speeds, i.e. constant speeds 1, 2, 3 and 4.</p> <p>1 = EXT/CS1/2/3 – Selects an external speed when no timer is active, selects Constant speed 1 when Timer 1 is active, Selects Constant speed 2 when Timer 2 is active and selects Constant speed 3 when both Timers 1 and 2 are active.</p> <table border="1"> <thead> <tr> <th>TIMER1</th> <th>TIMER2</th> <th>Function</th> </tr> </thead> <tbody> <tr> <td>0</td> <td>0</td> <td>External reference</td> </tr> <tr> <td>1</td> <td>0</td> <td>Constant speed 1 (1202)</td> </tr> <tr> <td>0</td> <td>1</td> <td>Constant speed 2 (1203)</td> </tr> <tr> <td>1</td> <td>1</td> <td>Constant speed 3 (1204)</td> </tr> </tbody> </table> <p>2 = CS1/2/3/4 – Selects Constant speed 1 when no timer is active, selects Constant speed 2 when Timer 1 is active, selects Constant speed 3 when Timer 2 is active, selects Constant speed 4 when both timers are active.</p> <table border="1"> <thead> <tr> <th>TIMER1</th> <th>TIMER2</th> <th>Function</th> </tr> </thead> <tbody> <tr> <td>0</td> <td>0</td> <td>Constant speed 1 (1202)</td> </tr> <tr> <td>1</td> <td>0</td> <td>Constant speed 2 (1203)</td> </tr> <tr> <td>0</td> <td>1</td> <td>Constant speed 3 (1204)</td> </tr> <tr> <td>1</td> <td>1</td> <td>Constant speed 4 (1205)</td> </tr> </tbody> </table>	TIMER1	TIMER2	Function	0	0	External reference	1	0	Constant speed 1 (1202)	0	1	Constant speed 2 (1203)	1	1	Constant speed 3 (1204)	TIMER1	TIMER2	Function	0	0	Constant speed 1 (1202)	1	0	Constant speed 2 (1203)	0	1	Constant speed 3 (1204)	1	1	Constant speed 4 (1205)
TIMER1	TIMER2	Function																													
0	0	External reference																													
1	0	Constant speed 1 (1202)																													
0	1	Constant speed 2 (1203)																													
1	1	Constant speed 3 (1204)																													
TIMER1	TIMER2	Function																													
0	0	Constant speed 1 (1202)																													
1	0	Constant speed 2 (1203)																													
0	1	Constant speed 3 (1204)																													
1	1	Constant speed 4 (1205)																													



### Group 13: Analog Inputs

This group defines the limits and the filtering for analog inputs.

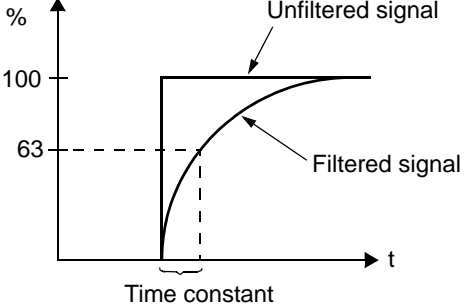
Code	Description
1301	<p><b>MINIMUM AI1</b></p> <p>Defines the minimum value of the analog input.</p> <ul style="list-style-type: none"> <li>Define value as a percent of the full analog signal range. See example below.</li> <li>The minimum analog input signal corresponds to 1104 REF1 MIN or 1107 REF2 MIN.</li> <li>MINIMUM AI cannot be greater than MAXIMUM AI.</li> <li>These parameters (reference and analog min. and max. settings) provide scale and offset adjustment for the reference.</li> <li>See figure at parameter 1104.</li> </ul> <p><b>Example.</b> To set the minimum analog input value to 4 mA:</p> <ul style="list-style-type: none"> <li>Configure the analog input for 0...20 mA current signal.</li> <li>Calculate the minimum (4 mA) as a percent of full range (20 mA) = <math>4 \text{ mA} / 20 \text{ mA} * 100\% = 20\%</math></li> </ul>
1302	<p><b>MAXIMUM AI1</b></p> <p>Defines the maximum value of the analog input.</p> <ul style="list-style-type: none"> <li>Define value as a percent of the full analog signal range.</li> <li>The maximum analog input signal corresponds to 1105 REF1 MAX or 1108 REF2 MAX.</li> <li>See figure at parameter 1104.</li> </ul>
1303	<p><b>FILTER AI1</b></p> <p>Defines the filter time constant for analog input 1 (AI1).</p> <ul style="list-style-type: none"> <li>The filtered signal reaches 63% of a step change within the time specified.</li> </ul> 
1304	<p><b>MINIMUM AI2</b></p> <p>Defines the minimum value of the analog input.</p> <ul style="list-style-type: none"> <li>See MINIMUM AI1 above.</li> </ul>
1305	<p><b>MAXIMUM AI2</b></p> <p>Defines the maximum value of the analog input.</p> <ul style="list-style-type: none"> <li>See MAXIMUM AI1 above.</li> </ul>
1306	<p><b>FILTER AI2</b></p> <p>Defines the filter time constant for analog input 2 (AI2).</p> <ul style="list-style-type: none"> <li>See FILTER AI1 above.</li> </ul>

## Group 14: Relay Outputs

This group defines the condition that activates each of the relay outputs.

Code	Description
1401	<p><b>RELAY OUTPUT 1</b></p> <p>Defines the event or condition that activates relay 1 – what relay output 1 means.</p> <p>0 = NOT SEL – Relay is not used and is de-energized.</p> <p>1 = READY – Energize relay when drive is ready to function. Requires:</p> <ul style="list-style-type: none"> <li>• Run enable signal present.</li> <li>• No faults exist.</li> <li>• Supply voltage is within range.</li> <li>• Emergency Stop command is not on.</li> </ul> <p>2 = RUN – Energize relay when the drive is running.</p> <p>3 = FAULT (-1) – Energize relay when power is applied. De-energizes when a fault occurs.</p> <p>4 = FAULT – Energize relay when a fault is active.</p> <p>5 = ALARM – Energize relay when an alarm is active.</p> <p>6 = REVERSED – Energize relay when motor rotates in reverse direction.</p> <p>7 = STARTED – Energize relay when drive receives a start command (even if Run Enable signal is not present). De-energized relay when drive receives a stop command or a fault occurs.</p> <p>8 = SUPRV1 OVER – Energize relay when first supervised parameter (3201) exceeds the limit (3203).</p> <ul style="list-style-type: none"> <li>• See "Group 32: Supervision" starting on page 109.</li> </ul> <p>9 = SUPRV1 UNDER – Energize relay when first supervised parameter (3201) drops below the limit (3202).</p> <ul style="list-style-type: none"> <li>• See "Group 32: Supervision" starting on page 109.</li> </ul> <p>10 = SUPRV2 OVER – Energize relay when second supervised parameter (3204) exceeds the limit (3206).</p> <ul style="list-style-type: none"> <li>• See "Group 32: Supervision" starting on page 109.</li> </ul> <p>11 = SUPRV2 UNDER – Energize relay when second supervised parameter (3204) drops below the limit (3205).</p> <ul style="list-style-type: none"> <li>• See "Group 32: Supervision" starting on page 109.</li> </ul> <p>12 = SUPRV3 OVER – Energize relay when second supervised parameter (3207) exceeds the limit (3209).</p> <ul style="list-style-type: none"> <li>• See "Group 32: Supervision" starting on page 109.</li> </ul> <p>13 = SUPRV3 UNDER – Energize relay when second supervised parameter (3207) drops below the limit (3208).</p> <ul style="list-style-type: none"> <li>• See "Group 32: Supervision" starting on page 109.</li> </ul> <p>14 = AT SET POINT – Energize relay when the output frequency is equal to the reference frequency.</p> <p>15 = FAULT (RST) – Energize relay when the drive is in a fault condition and will reset after the programmed auto-reset delay.</p> <ul style="list-style-type: none"> <li>• See parameter 3103 delay time.</li> </ul> <p>16 = FLT/ALARM – Energize relay when fault or alarm occurs.</p> <p>17 = EXT CTRL – Energize relay when external control is selected.</p> <p>18 = REF 2 SEL – Energize relay when EXT2 is selected.</p> <p>19 = CONST FREQ – Energize relay when a constant speed is selected.</p> <p>20 = REF LOSS – Energize relay when reference or active control place is lost.</p> <p>21 = OVERCURRENT – Energize relay when an overcurrent alarm or fault occurs.</p> <p>22 = OVERVOLTAGE – Energize relay when an overvoltage alarm or fault occurs.</p> <p>23 = DRIVE TEMP – Energize relay when a drive overtemperature alarm or fault occurs.</p> <p>24 = UNDERVOLTAGE – Energize relay when an undervoltage alarm or fault occurs.</p> <p>25 = AI1 LOSS – Energize relay when AI1 signal is lost.</p> <p>26 = AI2 LOSS – Energize relay when AI2 signal is lost.</p> <p>27 = MOTOR TEMP – Energize relay when a motor overtemperature alarm or fault occurs.</p> <p>28 = STALL – Energize relay when a stall alarm or fault exists.</p> <p>29 = UNDERLOAD – Energize relay when an underload alarm or fault occurs.</p> <p>30 = PID SLEEP – Energize relay when the PID sleep function is active.</p> <p>31 = PFC – Use relay to start/stop motor in PFC control (See Group 81: PFC Control).</p> <ul style="list-style-type: none"> <li>• Use this option only when PFC control is used.</li> <li>• Selection activated / deactivated when drive is not running.</li> </ul> <p>32 = AUTOCHANGE – Energize relay when PFC autochange operation is performed.</p> <ul style="list-style-type: none"> <li>• Use this option only when PFC control is used.</li> </ul> <p>33 = FLUX READY – Energize relay when the motor is magnetized and able to supply nominal torque (motor has reached nominal magnetizing).</p> <p>34 = USER S2 – Energize relay when User Parameter Set 2 is active.</p>

Code	Description																																																																																																																																
	<p>35 = COMM – Energize relay based on input from fieldbus communication.</p> <ul style="list-style-type: none"> <li>Fieldbus writes binary code in parameter 0134 that can energize relay 1...relay 6 according to the following:</li> </ul> <table border="1"> <thead> <tr> <th>Par. 0134</th> <th>Binary</th> <th>RO6</th> <th>RO5</th> <th>RO4</th> <th>RO3</th> <th>RO2</th> <th>RO1</th> </tr> </thead> <tbody> <tr> <td>0</td> <td>000000</td> <td>0</td> <td>0</td> <td>0</td> <td>0</td> <td>0</td> <td>0</td> </tr> <tr> <td>1</td> <td>000001</td> <td>0</td> <td>0</td> <td>0</td> <td>0</td> <td>0</td> <td>1</td> </tr> <tr> <td>2</td> <td>000010</td> <td>0</td> <td>0</td> <td>0</td> <td>0</td> <td>1</td> <td>0</td> </tr> <tr> <td>3</td> <td>000011</td> <td>0</td> <td>0</td> <td>0</td> <td>0</td> <td>1</td> <td>1</td> </tr> <tr> <td>4</td> <td>000100</td> <td>0</td> <td>0</td> <td>0</td> <td>1</td> <td>0</td> <td>0</td> </tr> <tr> <td>5...62</td> <td>...</td> <td>...</td> <td>...</td> <td>...</td> <td>...</td> <td>...</td> <td>...</td> </tr> <tr> <td>63</td> <td>111111</td> <td>1</td> <td>1</td> <td>1</td> <td>1</td> <td>1</td> <td>1</td> </tr> </tbody> </table> <ul style="list-style-type: none"> <li>0 = De-energize relay, 1 = Energize relay.</li> </ul> <p>36 = COMM(-1) – Energize relay based on input from fieldbus communication.</p> <ul style="list-style-type: none"> <li>Fieldbus writes binary code in parameter 0134 that can energize relay 1...relay 6 according to the following:</li> </ul> <table border="1"> <thead> <tr> <th>Par. 0134</th> <th>Binary</th> <th>RO6</th> <th>RO5</th> <th>RO4</th> <th>RO3</th> <th>RO2</th> <th>RO1</th> </tr> </thead> <tbody> <tr> <td>0</td> <td>000000</td> <td>1</td> <td>1</td> <td>1</td> <td>1</td> <td>1</td> <td>1</td> </tr> <tr> <td>1</td> <td>000001</td> <td>1</td> <td>1</td> <td>1</td> <td>1</td> <td>1</td> <td>0</td> </tr> <tr> <td>2</td> <td>000010</td> <td>1</td> <td>1</td> <td>1</td> <td>1</td> <td>0</td> <td>1</td> </tr> <tr> <td>3</td> <td>000011</td> <td>1</td> <td>1</td> <td>1</td> <td>1</td> <td>0</td> <td>0</td> </tr> <tr> <td>4</td> <td>000100</td> <td>1</td> <td>1</td> <td>1</td> <td>0</td> <td>1</td> <td>1</td> </tr> <tr> <td>5...62</td> <td>...</td> <td>...</td> <td>...</td> <td>...</td> <td>...</td> <td>...</td> <td>...</td> </tr> <tr> <td>63</td> <td>111111</td> <td>0</td> <td>0</td> <td>0</td> <td>0</td> <td>0</td> <td>0</td> </tr> </tbody> </table> <ul style="list-style-type: none"> <li>0 = De-energize relay, 1 = Energize relay.</li> </ul> <p>37 = TIMER FUNCTION 1 – Energize relay when Timer Function 1 is active. See Group 36, Timer Functions.                      38...40 = TIMER FUNCTION 2...4 – Energize relay when Timer Function 2...4 is active. See Timer Function 1 above.                      41 = M. TRIG FAN – Energize relay when cooling fan counter is triggered. See Group 29, Maintenance Trig.                      42 = M. TRIG REV – Energize relay when revolutions counter is triggered. See Group 29, Maintenance Trig.                      43 = M. TRIG RUN – Energize relay when run time counter is triggered. See Group 29, Maintenance Trig.                      44 = M. TRIG MWH – Energize relay when MWh counter is triggered. See Group 29, Maintenance Trig.                      45 = RESERVED – Relay is not used and is de-energized.</p>	Par. 0134	Binary	RO6	RO5	RO4	RO3	RO2	RO1	0	000000	0	0	0	0	0	0	1	000001	0	0	0	0	0	1	2	000010	0	0	0	0	1	0	3	000011	0	0	0	0	1	1	4	000100	0	0	0	1	0	0	5...62	...	...	...	...	...	...	...	63	111111	1	1	1	1	1	1	Par. 0134	Binary	RO6	RO5	RO4	RO3	RO2	RO1	0	000000	1	1	1	1	1	1	1	000001	1	1	1	1	1	0	2	000010	1	1	1	1	0	1	3	000011	1	1	1	1	0	0	4	000100	1	1	1	0	1	1	5...62	...	...	...	...	...	...	...	63	111111	0	0	0	0	0	0
Par. 0134	Binary	RO6	RO5	RO4	RO3	RO2	RO1																																																																																																																										
0	000000	0	0	0	0	0	0																																																																																																																										
1	000001	0	0	0	0	0	1																																																																																																																										
2	000010	0	0	0	0	1	0																																																																																																																										
3	000011	0	0	0	0	1	1																																																																																																																										
4	000100	0	0	0	1	0	0																																																																																																																										
5...62	...	...	...	...	...	...	...																																																																																																																										
63	111111	1	1	1	1	1	1																																																																																																																										
Par. 0134	Binary	RO6	RO5	RO4	RO3	RO2	RO1																																																																																																																										
0	000000	1	1	1	1	1	1																																																																																																																										
1	000001	1	1	1	1	1	0																																																																																																																										
2	000010	1	1	1	1	0	1																																																																																																																										
3	000011	1	1	1	1	0	0																																																																																																																										
4	000100	1	1	1	0	1	1																																																																																																																										
5...62	...	...	...	...	...	...	...																																																																																																																										
63	111111	0	0	0	0	0	0																																																																																																																										
1402	<p><b>RELAY OUTPUT 2</b></p> <p>Defines the event or condition that activates relay 2 – what relay output 2 means.</p> <ul style="list-style-type: none"> <li>See 1401 RELAY OUTPUT 1.</li> </ul>																																																																																																																																
1403	<p><b>RELAY OUTPUT 3</b></p> <p>Defines the event or condition that activates relay 3 – what relay output 3 means.</p> <ul style="list-style-type: none"> <li>See 1401 RELAY OUTPUT 1.</li> </ul>																																																																																																																																
1404	<p><b>RO 1 ON DELAY</b></p> <p>Defines the switch-on delay for relay 1.</p> <ul style="list-style-type: none"> <li>On / off delays are ignored when relay output 1401 is set to PFC.</li> </ul>																																																																																																																																
1405	<p><b>RO 1 OFF DELAY</b></p> <p>Defines the switch-off delay for relay 1.</p> <ul style="list-style-type: none"> <li>On / off delays are ignored when relay output 1401 is set to PFC.</li> </ul>																																																																																																																																
1406	<p><b>RO 2 ON DELAY</b></p> <p>Defines the switch-on delay for relay 2.</p> <ul style="list-style-type: none"> <li>See RO 1 ON DELAY.</li> </ul>																																																																																																																																
1407	<p><b>RO 2 OFF DELAY</b></p> <p>Defines the switch-off delay for relay 2.</p> <ul style="list-style-type: none"> <li>See RO 1 OFF DELAY.</li> </ul>																																																																																																																																
1408	<p><b>RO 3 ON DELAY</b></p> <p>Defines the switch-on delay for relay 3.</p> <ul style="list-style-type: none"> <li>See RO 1 ON DELAY.</li> </ul>																																																																																																																																

Code	Description
1409	<b>RO 3 OFF DELAY</b> Switch-off delay for relay 3. • See RO 1 OFF DELAY.
1410	<b>RELAY OUTPUT 4...6</b> Defines the event or condition that activates relay 4...6 – what relay output 4...6 means.
1412	• See 1401 RELAY OUTPUT 1.
1413	<b>RO 4 ON DELAY</b> Defines the switch-on delay for relay 4. • See RO 1 ON DELAY.
1414	<b>RO 4 OFF DELAY</b> Defines the switch-off delay for relay 4. • See RO 1 OFF DELAY.
1415	<b>RO 5 ON DELAY</b> Defines the switch-on delay for relay 5. • See RO 1 ON DELAY.
1416	<b>RO 5 OFF DELAY</b> Defines the switch-off delay for relay 5. • See RO 1 OFF DELAY.
1417	<b>RO 6 ON DELAY</b> Defines the switch-on delay for relay 6. • See RO 1 ON DELAY.
1418	<b>RO 6 OFF DELAY</b> Defines the switch-off delay for relay 6. • See RO 1 OFF DELAY.

### Group 15: Analog Outputs

This group defines the drive's analog (current signal) outputs. The drive's analog outputs can be:

- Any parameter of the Operating Data group (Group 01).
- Limited to programmable minimum and maximum values of output current.
- Scaled (and/or inverted) by defining the minimum and maximum values of the source parameter (or content). Defining an maximum value (parameter 1503 or 1509) that is less than the content minimum value (parameter 1502 or 1508) results in an inverted output.
- Filtered.

Code	Description
1501	<p><b>AO1 CONTENT SEL</b>                      Defines the content for analog output AO1.                      99 = EXCITE PTC – Provides a current source for sensor type PTC. Output = 1.6 mA. See Group 35.                      100 = EXCITE PT100 – Provides a current source for sensor type Pt100. Output = 9.1 mA. See Group 35.                      101...145 – Output corresponds to a parameter in the Operating Data group (Group 01).                      • Parameter defined by value (value 102 = parameter 0102)</p>
1502	<p><b>AO1 CONTENT MIN</b>                      Sets the minimum content value.                      • Content is the parameter selected by parameter 1501.                      • Minimum value refers to the minimum content value that will be converted to an analog output.                      • These parameters (content and current min. and max. settings) provide scale and offset adjustment for the output. See figure.</p>
1503	<p><b>AO1 CONTENT MAX</b>                      Sets the maximum content value                      • Content is the parameter selected by parameter 1501.                      • Maximum value refers to the maximum content value that will be converted to an analog output.</p>
1504	<p><b>MINIMUM AO1</b>                      Sets the minimum output current.</p>
1505	<p><b>MAXIMUM AO1</b>                      Sets the maximum output current.</p>
1506	<p><b>FILTER AO1</b>                      Defines the filter time constant for AO1.                      • The filtered signal reaches 63% of a step change within the time specified.                      • See figure in parameter 1303.</p>
1507	<p><b>AO2 CONTENT SEL</b>                      Defines the content for analog output AO2. See AO1 CONTENT SEL above.</p>
1508	<p><b>AO2 CONTENT MIN</b>                      Sets the minimum content value. See AO1 CONTENT MIN above.</p>
1509	<p><b>AO2 CONTENT MAX</b>                      Sets the maximum content value. See AO1 CONTENT MAX above.</p>
1510	<p><b>MINIMUM AO2</b>                      Sets the minimum output current. See MINIMUM AO1 above.</p>
1511	<p><b>MAXIMUM AO2</b>                      Sets the maximum output current. See MAXIMUM AO1 above.</p>
1512	<p><b>FILTER AO2</b>                      Defines the filter time constant for AO2. See FILTER AO1 above.</p>

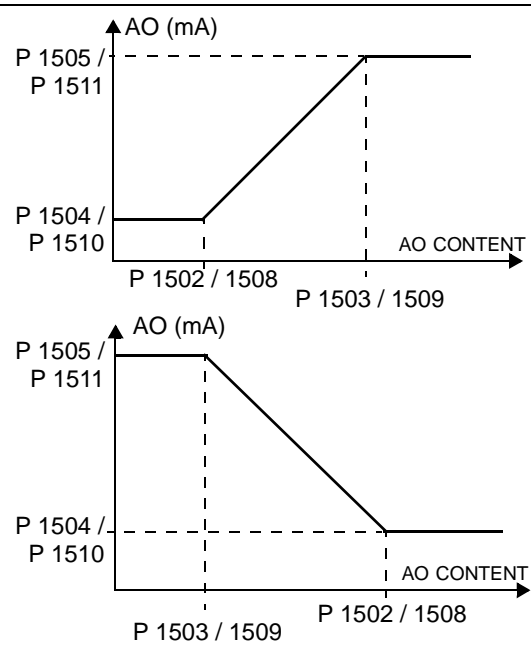

## Group 16: System Controls

This group defines a variety of system level locks, resets and enables.

Code	Description
1601	<p><b>RUN ENABLE</b></p> <p>Selects the source of the run enable signal.</p> <p>0 = NOT SEL – Allows the drive to start without an external run enable signal.</p> <p>1 = DI1 – Defines digital input DI1 as the run enable signal.</p> <ul style="list-style-type: none"> <li>This digital input must be activated for run enable.</li> <li>If the voltage drops and de-activates this digital input, the drive will coast to stop and not start until the run enable signal resumes.</li> </ul> <p>2...6 = DI2...DI6 – Defines digital input DI2...DI6 as the run enable signal.</p> <ul style="list-style-type: none"> <li>See DI1 above.</li> </ul> <p>7 = COMM – Assigns the fieldbus Command Word as the source for the run enable signal.</p> <ul style="list-style-type: none"> <li>Bit 6 of the Command Word 1 (parameter 0301) activates the run disable signal.</li> <li>See fieldbus user's manual for detailed instructions.</li> </ul> <p>-1 = DI1(INV) – Defines an inverted digital input DI1 as the run enable signal.</p> <ul style="list-style-type: none"> <li>This digital input must be de-activated for run enable.</li> <li>If this digital input activates, the drive will coast to stop and not start until the run enable signal resumes.</li> </ul> <p>-2...-6 = DI2(INV)...DI6(INV) – Defines an inverted digital input DI2...DI6 as the run enable signal.</p> <ul style="list-style-type: none"> <li>See DI1(INV) above.</li> </ul>
1602	<p><b>PARAMETER LOCK</b></p> <p>Determines if the control panel can change parameter values.</p> <ul style="list-style-type: none"> <li>This lock does not limit parameter changes made by macros.</li> <li>This lock does not limit parameter changes written by fieldbus inputs.</li> <li>This parameter value can be changed only if the correct pass code is entered. See parameter 1603, PASS CODE.</li> </ul> <p>0 = LOCKED – You cannot use the control panel to change parameter values.</p> <ul style="list-style-type: none"> <li>The lock can be opened by entering the valid pass code to parameter 1603.</li> </ul> <p>1 = OPEN – You can use the control panel to change parameter values.</p> <p>2 = NOT SAVED – You can use the control panel to change parameter values, but they are not stored in permanent memory.</p> <ul style="list-style-type: none"> <li>Set parameter 1607 PARAM SAVE to 1 (SAVE) to store changed parameter values to memory.</li> </ul>
1603	<p><b>PASS CODE</b></p> <p>Entering the correct pass code allows you to change the parameter lock.</p> <ul style="list-style-type: none"> <li>See parameter 1602 above.</li> <li>The code 358 allows you to change the value of the parameter 1602 once.</li> <li>This entry reverts back to 0 automatically.</li> </ul>
1604	<p><b>FAULT RESET SEL</b></p> <p>Selects the source for the fault reset signal. The signal resets the drive after a fault trip if the cause of the fault no longer exists.</p> <p>0 = KEYPAD – Defines the control panel as the only fault reset source.</p> <ul style="list-style-type: none"> <li>Fault reset is always possible with control panel.</li> </ul> <p>1 = DI1 – Defines digital input DI1 as a fault reset source.</p> <ul style="list-style-type: none"> <li>Activating the digital input resets the drive.</li> </ul> <p>2...6 = DI2...DI6 – Defines digital input DI2...DI6 as a fault reset source.</p> <ul style="list-style-type: none"> <li>See DI1 above.</li> </ul> <p>7 = START/STOP – Defines the Stop command as a fault reset source.</p> <ul style="list-style-type: none"> <li>Do not use this option when fieldbus communication provides the start, stop and direction commands.</li> </ul> <p>8 = COMM – Defines the fieldbus as a fault reset source.</p> <ul style="list-style-type: none"> <li>The Command Word is supplied through fieldbus communication.</li> <li>The bit 4 of the Command Word 1 (parameter 0301) resets the drive.</li> </ul> <p>-1 = DI1(INV) – Defines an inverted digital input DI1 as a fault reset source.</p> <ul style="list-style-type: none"> <li>De-activating the digital input resets the drive.</li> </ul> <p>-2...-6 = DI2(INV)...DI6(INV) – Defines an inverted digital input DI2...DI6 as a fault reset source.</p> <ul style="list-style-type: none"> <li>See DI1(INV) above.</li> </ul>

Code	Description
1605	<p><b>USER PAR SET CHG</b></p> <p>Defines control for changing the user parameter set.</p> <ul style="list-style-type: none"> <li>• See parameter 9902 (APPLIC MACRO).</li> <li>• The drive must be stopped to change User Parameter Sets.</li> <li>• During a change, the drive will not start.</li> </ul> <p><b>Note:</b> Always save the User Parameter Set after changing any parameter settings, or performing a motor identification.</p> <ul style="list-style-type: none"> <li>• Whenever the power is cycled, or parameter 9902 (APPLIC MACRO) is changed, the drive loads the last settings saved. Any unsaved changes to a user parameter set are lost.</li> </ul> <p><b>Note:</b> The value of this parameter (1605) is not included in the User Parameter Sets, and does not change if User Parameter Sets change.</p> <p><b>Note:</b> You can use a relay output to supervise the selection of User Parameter Set 2.</p> <ul style="list-style-type: none"> <li>• See parameter 1401.</li> </ul> <p>0 = NOT SEL – Defines the control panel (using parameter 9902) as the only control for changing User Parameter Sets.</p> <p>1 = DI1 – Defines digital input DI1 as a control for changing User Parameter Sets.</p> <ul style="list-style-type: none"> <li>• The drive loads User Parameter Set 1 on the falling edge of the digital input.</li> <li>• The drive loads User Parameter Set 2 on the rising edge of the digital input.</li> <li>• The User Parameter Set changes only when the drive is stopped.</li> </ul> <p>2...6 = DI2...DI6 – Defines digital input DI2...DI6 as a control for changing User Parameter Sets.</p> <ul style="list-style-type: none"> <li>• See DI1 above.</li> </ul> <p>-1 = DI1(INV) – Defines an inverted digital input DI1 as a control for changing User Parameter Sets.</p> <ul style="list-style-type: none"> <li>• The drive loads User Parameter Set 1 on the rising edge of the digital input.</li> <li>• The drive loads User Parameter Set 2 on the falling edge of the digital input.</li> <li>• The User Parameter Set changes only when the drive is stopped.</li> </ul> <p>-2...-6 = DI2(INV)...DI6(INV) – Defines an inverted digital input DI2...DI6 as a control for changing User Parameter Sets.</p> <ul style="list-style-type: none"> <li>• See DI1(INV) above.</li> </ul>
1606	<p><b>LOCAL LOCK</b></p> <p>Defines control for the use of the LOC mode. The LOC mode allows drive control from the control panel.</p> <ul style="list-style-type: none"> <li>• When LOCAL LOCK is active, the control panel cannot change to LOC mode.</li> </ul> <p>0 = NOT SEL – Disables the lock. The control panel can select LOC and control the drive.</p> <p>1 = DI1 – Defines digital input DI1 as the control for setting the local lock.</p> <ul style="list-style-type: none"> <li>• Activating the digital input locks out local control.</li> <li>• De-activating the digital input enable the LOC selection.</li> </ul> <p>2...6 = DI2...DI6 – Defines digital input DI2...DI6 as the control for setting the local lock.</p> <ul style="list-style-type: none"> <li>• See DI1 above.</li> </ul> <p>7 = ON – Sets the lock. The control panel cannot select LOC, and cannot control the drive.</p> <p>8 = COMM – Defines bit 14 of the Command Word 1 as the control for setting the local lock.</p> <ul style="list-style-type: none"> <li>• The Command Word is supplied through fieldbus communication.</li> <li>• The Command Word is 0301.</li> </ul> <p>-1 = DI1(INV) – Defines an inverted digital input DI1 as the control for setting the local lock.</p> <ul style="list-style-type: none"> <li>• De-activating the digital input locks out local control.</li> <li>• Activating the digital input enable the LOC selection.</li> </ul> <p>-2...-6 = DI2(INV)...DI6(INV) – Defines an inverted digital input DI2...DI6 as the control for setting the local lock.</p> <ul style="list-style-type: none"> <li>• See DI1(INV) above.</li> </ul>
1607	<p><b>PARAM. SAVE</b></p> <p>Saves all altered parameters to permanent memory.</p> <ul style="list-style-type: none"> <li>• Parameters altered through a fieldbus are not automatically saved to permanent memory. To save, you must use this parameter.</li> <li>• If 1602 PARAMETER LOCK = 2 (NOT SAVED), parameters altered from the control panel are not saved. To save, you must use this parameter.</li> <li>• If 1602 PARAMETER LOCK = 1 (OPEN), parameters altered from the control panel are stored immediately to permanent memory.</li> </ul> <p>0 = DONE – Value changes automatically when all parameters are saved.</p> <p>1 = SAVE – Saves altered parameters to permanent memory.</p>

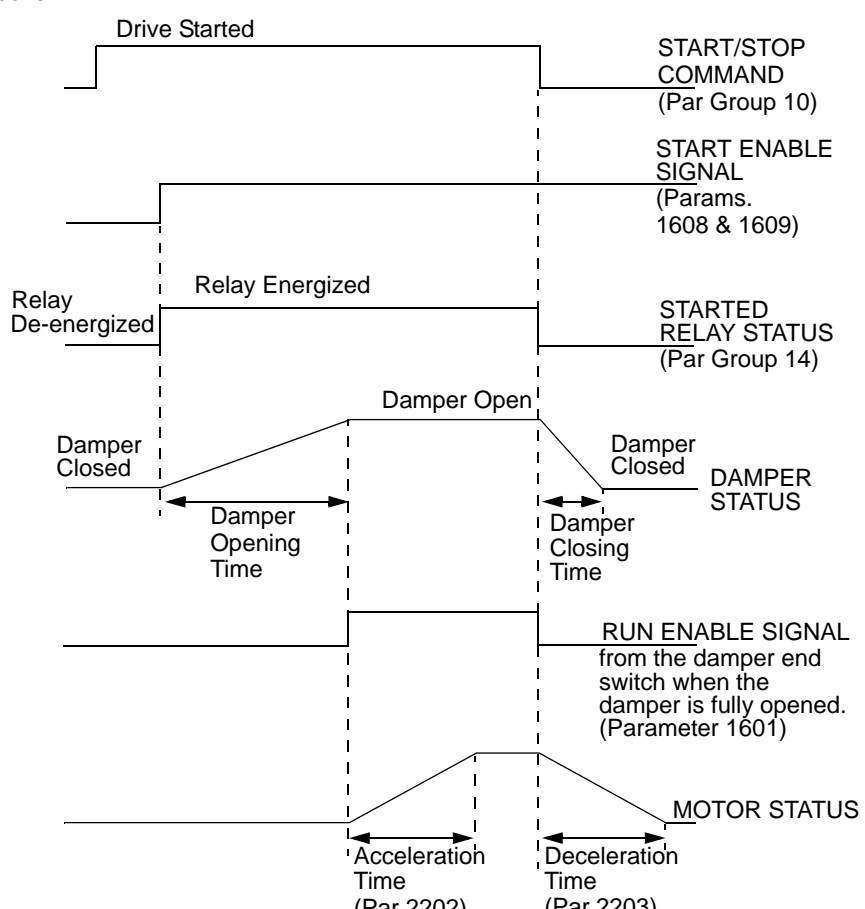
Code	Description
1608	<p><b>START ENABLE 1</b>                      Selects the source of the start enable 1 signal.</p> <p><b>Note:</b> Start enable functionality differs from the run enable functionality.</p> <p>0 = NOT SEL – Allows the drive to start without an external start enable signal.</p> <p>1 = DI1 – Defines digital input DI1 as the start enable 1 signal.</p> <ul style="list-style-type: none"> <li>• This digital input must be activated for start enable 1 signal.</li> <li>• If the voltage drops and de-activates this digital input, the drive will coast to stop and show alarm 2021 on the panel display. The drive will not start until start enable 1 signal resumes.</li> </ul> <p>2...6 = DI2...DI6 – Defines digital input DI2...DI6 as the start enable 1 signal.</p> <ul style="list-style-type: none"> <li>• See DI1 above.</li> </ul> <p>7 = COMM – Assigns the fieldbus Command Word as the source for the start enable 1 signal.</p> <ul style="list-style-type: none"> <li>• Bit 2 of the Command word 2 (parameter 0302) activates the start disable 1 signal.</li> <li>• See fieldbus user's manual for detailed instructions.</li> </ul> <p>(-1) = DI1(INV) – Defines an inverted digital input DI1 as the start enable 1 signal.</p> <p>(-2)...(-6) = DI2 (INV)...DI6(INV) – Defines an inverted digital input DI2...DI6 as the start enable 1 signal.</p> <ul style="list-style-type: none"> <li>• See DI1 (INV) above.</li> </ul>  <p>The diagram illustrates the timing sequence for starting the drive. It shows several signals over time:</p> <ul style="list-style-type: none"> <li><b>START/STOP COMMAND (Par Group 10):</b> A step function that goes high to initiate the start.</li> <li><b>START ENABLE SIGNAL (Params. 1608 &amp; 1609):</b> A step function that goes high after the start command, enabling the start.</li> <li><b>Relay De-energized / Relay Energized:</b> The relay transitions from de-energized to energized when the start enable signal is active.</li> <li><b>DAMPER STATUS:</b> Shows the damper moving from a closed state to an open state. The <b>Damper Opening Time</b> is the duration from the start of opening to full opening. The <b>Damper Closing Time</b> is the duration from the start of closing to full closing.</li> <li><b>RUN ENABLE SIGNAL from the damper end switch when the damper is fully opened. (Parameter 1601):</b> This signal becomes high only after the damper is fully open.</li> <li><b>MOTOR STATUS:</b> Shows the motor starting to accelerate. The <b>Acceleration Time (Par 2202)</b> is the time to reach full speed, and the <b>Deceleration Time (Par 2203)</b> is the time to stop.</li> </ul>



Code	Description
1609	<p><b>START ENABLE 2</b></p> <p>Selects the source of the start enable 2 signal.</p> <p><b>Note:</b> Start enable functionality differs from the run enable functionality.</p> <p>0 = NOT SEL – Allows the drive to start without an external start enable signal.</p> <p>1 = DI1 – Defines digital input DI1 as the start enable 2 signal. This digital input must be activated for start enable 2 signal. If the voltage drops and de-activates this digital input, the drive will coast to stop and show alarm 2022 on panel display. The drive will not start until start enable 2 signal resumes.</p> <p>2...6 = DI2...DI6 – Defines digital input DI2...DI6 as the start enable 2 signal. See DI1 above.</p> <p>7 = COMM – Assigns the fieldbus Command Word as the source for the start enable 2 signal. Bit 3 of the Command word 2 (parameter 0302) activates the start disable 2 signal. See fieldbus user's manual for detailed instructions.</p> <p>(-1) = DI1(INV) – Defines an inverted digital input DI1 as the start enable 2 signal.</p> <p>(-2)...(-6) = DI2(INV)...DI6(INV) – Defines an inverted digital input DI2...DI6 as the start enable 2 signal.</p> <ul style="list-style-type: none"> <li>• See DI1 (INV) above.</li> </ul>
1610	<p><b>DISPLAY ALARMS</b></p> <p>Controls the visibility of the following alarms:</p> <ul style="list-style-type: none"> <li>• 2001, Overcurrent alarm</li> <li>• 2002, Overvoltage alarm</li> <li>• 2003, Undervoltage alarm</li> <li>• 2009, Device overtemperature alarm</li> </ul> <p>0 = NO – The above alarms are suppressed.</p> <p>1 = YES – All of the above alarms are enabled.</p>

## Group 20: Limits

This group defines minimum and maximum limits to follow in driving the motor – speed, frequency, current, torque, etc.

Code	Description
2001	<p><b>MINIMUM SPEED</b> Defines the minimum speed (rpm) allowed.</p> <ul style="list-style-type: none"> <li>• A positive (or zero) minimum speed value defines two ranges, one positive and one negative.</li> <li>• A negative minimum speed value defines one speed range.</li> <li>• See figure.</li> </ul>
2002	<p><b>MAXIMUM SPEED</b> Defines the maximum speed (rpm) allowed.</p>
2003	<p><b>MAX CURRENT</b> Defines the maximum output current (A) supplied by the drive to the motor.</p>
2005	<p><b>OVERVOLT CTRL</b> Sets the DC overvoltage controller on or off.</p> <ul style="list-style-type: none"> <li>• Fast braking of a high inertia load causes the DC bus voltage to rise to the overvoltage control limit. To prevent the DC voltage from exceeding the trip limit, the overvoltage controller automatically decreases the braking torque by increasing output frequency.</li> </ul> <p>0 = DISABLE – Disables controller. 1 = ENABLE – Enables controller</p> <p><b>Warning! If a braking chopper or a braking resistor is connected to the drive, this parameter value must be set to 0 to ensure proper operation of the chopper.</b></p>
2006	<p><b>UNDERVOLT CTRL</b> Sets the DC undervoltage controller on or off. When on:</p> <ul style="list-style-type: none"> <li>• If the DC bus voltage drops due to loss of input power, the undervoltage controller decreases the motor speed in order to keep the DC bus voltage above the lower limit.</li> <li>• When the motor speed decreases, the inertia of the load causes regeneration back into the drive, keeping the DC bus charged, and preventing an undervoltage trip.</li> <li>• The DC undervoltage controller increases power loss ride-through on systems with a high inertia, such as a centrifuge or a fan.</li> </ul> <p>0 = DISABLE – Disables controller. 1 = ENABLE (TIME) – Enables controller with 500 ms time limit for operation. 2 = ENABLE – Enables controller without maximum time limit for operation.</p>

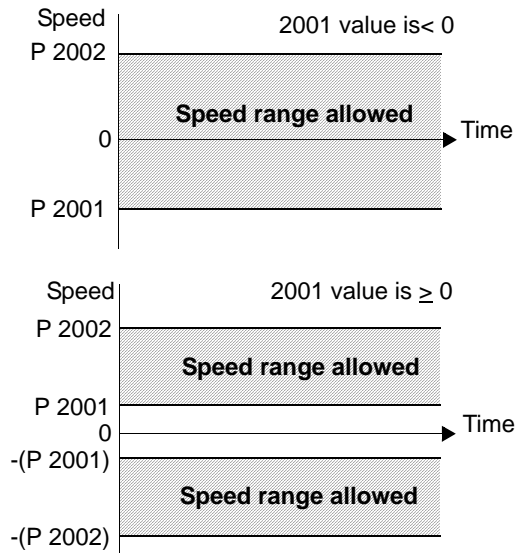

Code	Description	
2007	<p><b>MINIMUM FREQ</b></p> <p>Defines the minimum limit for the drive output frequency.</p> <ul style="list-style-type: none"> <li>• A positive or zero minimum frequency value defines two ranges, one positive and one negative.</li> <li>• A negative minimum frequency value defines one speed range.</li> </ul> <p>See figure.</p> <p><b>Note!</b> Keep <math>\text{MINIMUM FREQ} \leq \text{MAXIMUM FREQ}</math>.</p>	
2008	<p><b>MAXIMUM FREQ</b></p> <p>Defines the maximum limit for the drive output frequency.</p>	
2013	<p><b>MIN TORQUE SEL</b></p> <p>Defines control of the selection between two minimum torque limits (2015 MIN TORQUE 1 and 2016 MIN TORQUE 2).</p> <p>0 = MIN TORQUE 1 – Selects 2015 MIN TORQUE 1 as the minimum limit used.</p> <p>1 = DI1 – Defines digital input DI1 as the control for selecting the minimum limit used.</p> <ul style="list-style-type: none"> <li>• Activating the digital input selects MIN TORQUE 2 value.</li> <li>• De-activating the digital input selects MIN TORQUE 1 value.</li> </ul> <p>2...6 = DI2...DI6 – Defines digital input DI2...DI6 as the control for selecting the minimum limit used.</p> <ul style="list-style-type: none"> <li>• See DI1 above.</li> </ul> <p>7 = COMM – Defines bit 15 of the Command Word 1 as the control for selecting the minimum limit used.</p> <ul style="list-style-type: none"> <li>• The Command Word is supplied through fieldbus communication.</li> <li>• The Command Word is parameter 0301.</li> </ul> <p>-1 = DI1(INV) – Defines an inverted digital input DI1 as the control for selecting the minimum limit used.</p> <ul style="list-style-type: none"> <li>• Activating the digital input selects MIN TORQUE 1 value.</li> <li>• De-activating the digital input selects MIN TORQUE 2 value.</li> </ul> <p>-2...-6 = DI2(INV)...DI6(INV) – Defines an inverted digital input DI2...DI6 as the control for selecting the minimum limit used.</p> <ul style="list-style-type: none"> <li>• See DI1(INV) above.</li> </ul>	
2014	<p><b>MAX TORQUE SEL</b></p> <p>Defines control of the selection between two maximum torque limits (2017 MAX TORQUE 1 and 2018 MAX TORQUE 2).</p> <p>0 = MAX TORQUE 1 – Selects 2017 MAX TORQUE 1 as the maximum limit used.</p> <p>1 = DI1 – Defines digital input DI1 as the control for selecting the maximum limit used.</p> <ul style="list-style-type: none"> <li>• Activating the digital input selects MAX TORQUE 2 value.</li> <li>• De-activating the digital input selects MAX TORQUE 1 value.</li> </ul> <p>2...6 = DI2...DI6 – Defines digital input DI2...DI6 as the control for selecting the maximum limit used.</p> <ul style="list-style-type: none"> <li>• See DI1 above.</li> </ul> <p>7 = COMM – Defines bit 15 of the Command Word 1 as the control for selecting the maximum limit used.</p> <ul style="list-style-type: none"> <li>• The Command Word is supplied through fieldbus communication.</li> <li>• The Command Word is parameter 0301.</li> </ul> <p>-1 = DI1(INV) – Defines an inverted digital input di1 as the control for selecting the maximum limit used.</p> <ul style="list-style-type: none"> <li>• Activating the digital input selects MAX TORQUE 1 value.</li> <li>• De-activating the digital input selects MAX TORQUE 2 value.</li> </ul> <p>-2...-6 = DI2(INV)...DI6(INV) – Defines an inverted digital input DI2...DI6 as the control for selecting the maximum limit used.</p> <ul style="list-style-type: none"> <li>• See DI1(INV) above.</li> </ul>	
2015	<p><b>MIN TORQUE 1</b></p> <p>Sets the first minimum limit for torque (%). Value is a percent of the motor nominal torque.</p>	
2016	<p><b>MIN TORQUE 2</b></p> <p>Sets the second minimum limit for torque (%). Value is a percent of the motor nominal torque.</p>	

Code	Description
2017	<b>MAX TORQUE 1</b> Sets the first maximum limit for torque (%). Value is a percent of the motor nominal torque.
2018	<b>MAX TORQUE 2</b> Sets the second maximum limit for torque (%). Value is a percent of the motor nominal torque.

### Group 21: Start/Stop

This group defines how the motor starts and stops. The ACS550 supports several start and stop modes.

Code	Description
2101	<p><b>START FUNCTION</b></p> <p>Selects the motor start method.</p> <p>1 = AUTO – Selects the automatic start mode.</p> <ul style="list-style-type: none"> <li>• Vector control modes: Optimal start in most cases. The drive automatically selects the correct output frequency to start a rotating motor.</li> <li>• SCALAR: SPEED mode: Immediate start from zero frequency.</li> </ul> <p>2 = DC MAGN – Selects the DC Magnetizing start mode.</p> <p><b>Note!</b> Mode cannot start a rotating motor.</p> <p><b>Note!</b> The drive starts when the set pre-magnetizing time (param. 2103) has passed, even if motor magnetization is not complete.</p> <ul style="list-style-type: none"> <li>• Vector control modes: Magnetizes the motor within the time determined by the parameter 2103 DC MAGN TIME using DC current. The normal control is released exactly after the magnetizing time. This selection guarantees the highest possible break-away torque.</li> <li>• SCALAR: SPEED mode: Magnetizes the motor within the time determined by the parameter 2103 DC MAGN TIME using DC current. The normal control is released exactly after the magnetizing time.</li> </ul> <p>3 = SCALAR FLYSTART – Selects the flying start mode.</p> <ul style="list-style-type: none"> <li>• Vector control modes: Not applicable.</li> <li>• SCALAR: SPEED mode: The drive automatically selects the correct output frequency to start a rotating motor – useful if the motor is already rotating and if the drive will start smoothly at the current frequency.</li> </ul> <p>4 = TORQ BOOST – Selects the automatic torque boost mode (SCALAR: SPEED mode only).</p> <ul style="list-style-type: none"> <li>• May be necessary in drives with high starting torque.</li> <li>• Torque boost is only applied at start, ending when output frequency exceeds 20 Hz or when output frequency is equal to reference.</li> <li>• In the beginning the motor magnetizes within the time determined by the parameter 2103 DC MAGN TIME using DC current.</li> <li>• See parameter 2110 TORQ BOOST CURR.</li> </ul> <p>5 = FLYSTART + TORQ BOOST – Selects both the flying start and the torque boost mode (SCALAR: SPEED mode only).</p> <ul style="list-style-type: none"> <li>• Flying start routine is performed first and the motor is magnetized. If the speed is found to be zero, the torque boost is done.</li> </ul>
2102	<p><b>STOP FUNCTION</b></p> <p>Selects the motor stop method.</p> <p>1 = COAST – Selects cutting off the motor power as the stop method. The motor coasts to stop.</p> <p>2 = RAMP – Selects using a deceleration ramp</p> <ul style="list-style-type: none"> <li>• Deceleration ramp is defined by 2203 DECELER TIME 1 or 2206 DECELER TIME 2 (whichever is active).</li> </ul>
2103	<p><b>DC MAGN TIME</b></p> <p>Defines the pre-magnetizing time for the DC Magnetizing start mode.</p> <ul style="list-style-type: none"> <li>• Use parameter 2101 to select the start mode.</li> <li>• After the start command, the drive pre-magnetizes the motor for the time defined here, and then starts the motor.</li> <li>• Set the pre-magnetizing time just long enough to allow full motor magnetization. Too long a time heats the motor excessively.</li> </ul>
2104	<p><b>DC CURR CTL</b></p> <p>Selects whether DC current is used for braking or DC Hold.</p> <p>0 = NOT SEL – Disables the DC current operation.</p> <p>1 = DC HOLD – Enables the DC Hold function. See diagram.</p> <ul style="list-style-type: none"> <li>• Requires parameter 9904 MOTOR CTRL MODE = 1 (VECTOR SPEED)</li> <li>• Stops generating sinusoidal current and injects DC into the motor when both the reference and the motor speed drop below the value of parameter 2105.</li> <li>• When the reference rises above the level of parameter 2105 the drive resumes normal operation.</li> </ul> <p>2 = DC BRAKING – Enables the DC Injection Braking after modulation has stopped.</p> <ul style="list-style-type: none"> <li>• If parameter 2102 STOP FUNCTION is 1 (COAST), braking is applied after start is removed.</li> <li>• If parameter 2102 STOP FUNCTION is 2 (RAMP), braking is applied after ramp.</li> </ul>

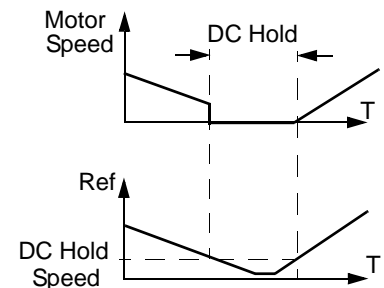

Code	Description
2105	<p><b>DC HOLD SPEED</b></p> <p>Sets the speed for DC Hold. Requires that parameter 2104 DC CURR CTL = 1 (DC HOLD).</p>
2106	<p><b>DC CURR REF</b></p> <p>Defines the DC current control reference as a percentage of parameter 9906 (MOTOR NOM CURR).</p>
2107	<p><b>DC BRAKE TIME</b></p> <p>Defines the DC brake time after modulation has stopped, if parameter 2104 is 2 (DC BRAKING).</p>
2108	<p><b>START INHIBIT</b></p> <p>Sets the Start inhibit function on or off. The Start inhibit function ignores a pending start command in any of the following situations (a new start command is required):</p> <ul style="list-style-type: none"> <li>• A fault is reset.</li> <li>• Run Enable (parameter 1601) activates while start command is active.</li> <li>• Mode changes from local to remote.</li> <li>• Control switches from EXT1 to EXT2.</li> <li>• Control switches from EXT2 to EXT1.</li> </ul> <p>0 = OFF – Disables the Start inhibit function. 1 = ON – Enables the Start inhibit function.</p>
2109	<p><b>EM STOP SEL</b></p> <p>Defines control of the Emergency stop command. When activated:</p> <ul style="list-style-type: none"> <li>• Emergency stop decelerates the motor using the emergency stop ramp (parameter 2208 EM DEC TIME).</li> <li>• Requires an external stop command and removal of the emergency stop command before drive can restart.</li> </ul> <p>0 = NOT SEL – Disables the Emergency stop function through digital inputs. 1 = DI1 – Defines digital input DI1 as the control for Emergency stop command.</p> <ul style="list-style-type: none"> <li>• Activating the digital input issues an Emergency stop command.</li> <li>• De-activating the digital input removes the Emergency stop command.</li> </ul> <p>2...6 = DI2...DI6 – Defines digital input DI2...DI6 as the control for Emergency stop command.</p> <ul style="list-style-type: none"> <li>• See DI1 above.</li> </ul> <p>-1 = DI1(INV) – Defines an inverted digital input DI1 as the control for Emergency stop command.</p> <ul style="list-style-type: none"> <li>• De-activating the digital input issues an Emergency stop command.</li> <li>• Activating the digital input removes the Emergency stop command.</li> </ul> <p>-2...-6 = DI2(INV)...DI6(INV) – Defines an inverted digital input DI2...DI6 as the control for Emergency stop command.</p> <ul style="list-style-type: none"> <li>• See DI1(INV) above.</li> </ul>
2110	<p><b>TORQ BOOST CURR</b></p> <p>Sets the maximum supplied current during torque boost.</p> <ul style="list-style-type: none"> <li>• See parameter 2101 START FUNCTION.</li> </ul>

**Group 22: Accel/Decel**

This group defines ramps that control the rate of acceleration and deceleration. You define these ramps as a pair, one for acceleration and one for deceleration. You can define two pairs of ramps and use a digital input to select one or the other pair.

Code	Description
2201	<p><b>ACC/DEC 1/2 SEL</b></p> <p>Defines control for selection of acceleration/deceleration ramps.</p> <ul style="list-style-type: none"> <li>Ramps are defined in pairs, one each for acceleration and deceleration.</li> <li>See below for the ramp definition parameters.</li> </ul> <p>0 = NOT SEL – Disables selection, the first ramp pair is used.</p> <p>1 = DI1 – Defines digital input DI1 as the control for ramp pair selection.</p> <ul style="list-style-type: none"> <li>Activating the digital input selects ramp pair 2.</li> <li>De-activating the digital input selects ramp pair 1.</li> </ul> <p>2...6 = DI2...DI6 – Defines digital input DI2...DI6 as the control for ramp pair selection.</p> <ul style="list-style-type: none"> <li>See DI1 above.</li> </ul> <p>7 = COMM – Defines serial communication as the control for ramp pair selection.</p> <p>-1 = DI1(INV) – Defines an inverted digital input DI1 as the control for ramp pair selection.</p> <ul style="list-style-type: none"> <li>De-activating the digital input selects ramp pair 2</li> <li>Activating the digital input selects ramp pair 1.</li> </ul> <p>-2...-6 = DI2(INV)...DI6(INV) – Defines an inverted digital input DI2...DI6 as the control for ramp pair selection.</p> <ul style="list-style-type: none"> <li>See DI1(INV) above.</li> </ul>
2202	<p><b>ACCELER TIME 1</b></p> <p>Sets the acceleration time for zero to maximum frequency for ramp pair 1. See A in figure.</p> <ul style="list-style-type: none"> <li>Actual acceleration time also depends on 2204 RAMP SHAPE.</li> <li>See 2008 MAXIMUM FREQUENCY.</li> </ul>
2203	<p><b>DECELER TIME 1</b></p> <p>Sets the deceleration time for maximum frequency to zero for ramp pair 1.</p> <ul style="list-style-type: none"> <li>Actual deceleration time also depends on 2204 RAMP SHAPE.</li> <li>See 2008 MAXIMUM FREQUENCY.</li> </ul>
2204	<p><b>RAMP SHAPE 1</b></p> <p>Selects the shape of the acceleration/deceleration ramp for ramp pair 1. See B in figure.</p> <ul style="list-style-type: none"> <li>Shape is defined as a ramp, unless additional time is specified here to reach the maximum frequency. A longer time provides a softer transition at each end of the slope. The shape becomes an s-curve.</li> <li>Rule of thumb: 1/5 is a suitable relation between the ramp shape time and the acceleration ramp time.</li> </ul> <p>0.0 = LINEAR – Specifies linear acceleration/deceleration ramps for ramp pair 1.</p> <p>0.1...1000.0 = S-CURVE – Specifies s-curve acceleration/deceleration ramps for ramp pair 1.</p>
	<p>A = 2202 ACCELERATION TIME B = 2204 RAMP SHAPE</p>
2205	<p><b>ACCELER TIME 2</b></p> <p>Sets the acceleration time (s) for zero to maximum frequency for ramp pair 2. See 2002 ACCELER TIME 1.</p>
2206	<p><b>DECELER TIME 2</b></p> <p>Sets the deceleration time for maximum frequency to zero for ramp pair 2. See 2003 DECELER TIME 1.</p>
2207	<p><b>RAMP SHAPE 2</b></p> <p>Selects the shape of the acceleration/deceleration ramp for ramp pair 2. See 2004 RAMP SHAPE 1.</p>
2208	<p><b>EM DEC TIME</b></p> <p>Sets the deceleration time for maximum frequency to zero for an emergency.</p> <ul style="list-style-type: none"> <li>See parameter 2109 EM STOP SEL.</li> <li>Ramp is linear.</li> </ul>

Code	Description
2209	<p><b>RAMP INPUT 0</b></p> <p>Defines control for forcing the ramp input to 0.</p> <p>0 = NOT SEL –</p> <p>1 = DI1 – Defines digital input DI1 as the control for forcing the ramp input to 0.</p> <ul style="list-style-type: none"> <li>• Activating the digital input forces ramp input to 0. Ramp output will ramp to 0 according to the currently used ramp time, after which it will stay at 0.</li> <li>• De-activating the digital input: ramp resumes normal operation.</li> </ul> <p>2...6 = DI2...DI6 – Defines digital input DI2...DI6 as the control for forcing the ramp input to 0.</p> <ul style="list-style-type: none"> <li>• See DI1 above.</li> </ul> <p>-1 = DI1(INV) – Defines an inverted digital input DI1 as the control for forcing the ramp input to 0.</p> <ul style="list-style-type: none"> <li>• De-activating the digital input forces ramp input to 0.</li> <li>• Activating the digital input: ramp resumes normal operation.</li> </ul> <p>-2...-6 = DI2(INV)...DI6(INV) – Defines an inverted digital input DI2...DI6 as the control for forcing the ramp function generator input to 0.</p> <ul style="list-style-type: none"> <li>• See DI1(INV) above.</li> </ul>



### Group 23: Speed Control

This group defines variables used for speed control operation.

Code	Description
2301	<p><b>PROP GAIN</b></p> <p>Sets the relative gain for the speed controller.</p> <ul style="list-style-type: none"> <li>• Larger values may cause speed oscillation.</li> <li>• The figure shows the speed controller output after an error step (error remains constant).</li> </ul> <p>Note! You can use parameter 2305, <b>AUTOTUNE RUN</b>, to automatically set proportional gain.</p>
2302	<p><b>INTEGRATION TIME</b></p> <p>Sets the integration time for the speed controller.</p> <ul style="list-style-type: none"> <li>• The integration time defines the rate at which the controller output changes for a constant error value.</li> <li>• Shorter integration times correct continuous errors faster.</li> <li>• Control becomes unstable if the integration time is too short.</li> <li>• The figure shows the speed controller output after an error step (error remains constant).</li> </ul> <p>Note! You can use parameter 2305, <b>AUTOTUNE RUN</b>, to automatically set integration time.</p>
2303	<p><b>DERIVATION TIME</b></p> <p>Sets the derivation time for the speed controller.</p> <ul style="list-style-type: none"> <li>• Derivative action makes the control more responsive to error value changes.</li> <li>• The longer the derivation time, the more the speed controller output is boosted during the change.</li> <li>• If the derivation time is set to zero, the controller works as a PI controller, otherwise as a PID controller.</li> </ul> <p>The figure below shows the speed controller output after an error step when the error remains constant.</p>

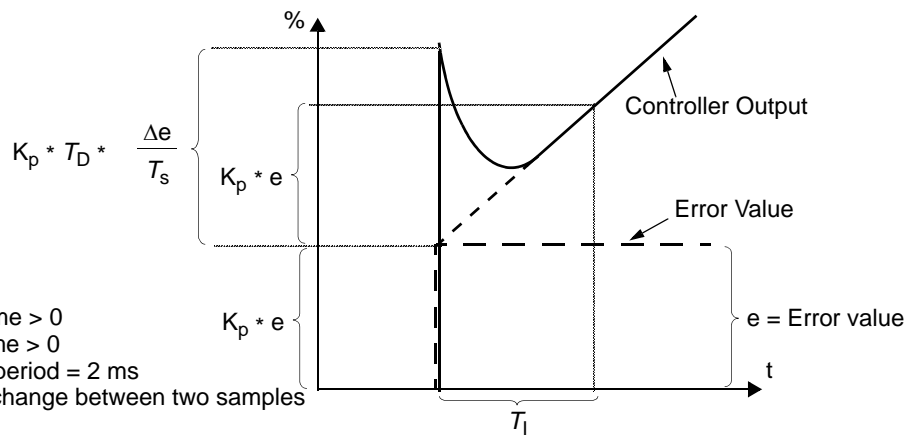
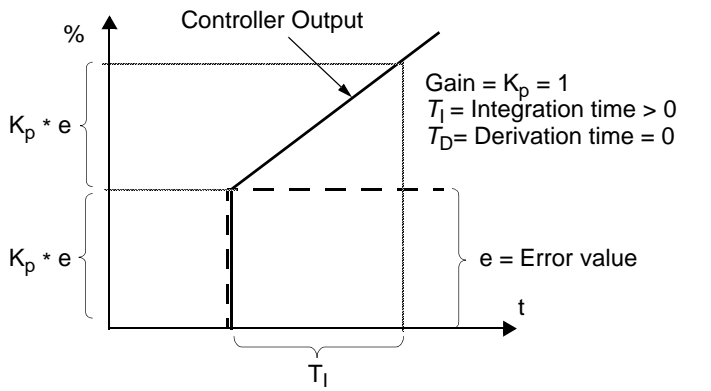
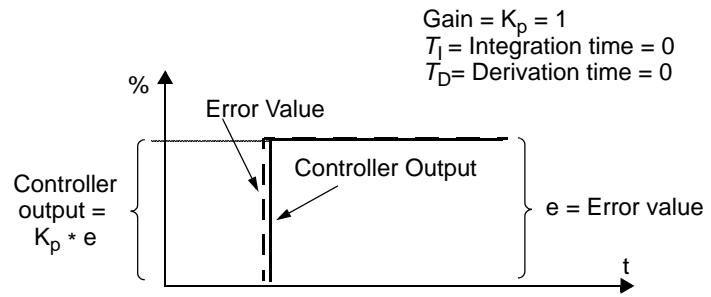

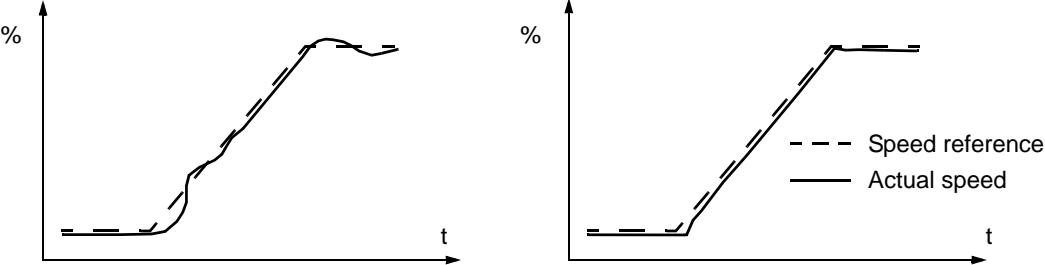
Code	Description
2304	<p><b>ACC COMPENSATION</b></p> <p>Sets the derivation time for acceleration compensation.</p> <ul style="list-style-type: none"> <li>• Adding a derivative of the reference to the output of the speed controller compensates for inertia during acceleration.</li> <li>• 2303 DERIVATION TIME describes the principle of derivative action.</li> <li>• Rule of thumb: Set this parameter between 50 and 100% of the sum of the mechanical time constants for the motor and the driven machine.</li> <li>• The figure shows the speed responses when a high inertia load is accelerated along a ramp.</li> </ul> <p><b>* No Acceleration Compensation</b>                      <b>Acceleration Compensation</b></p>  <p><b>*Note!</b> You can use parameter 2305 AUTOTUNE RUN to automatically set acceleration compensation.</p>
2305	<p><b>AUTOTUNE RUN</b></p> <p>Starts automatic tuning of the speed controller.</p> <p>0 = OFF – Disables the Autotune creation process. (Does not disable the operation of Autotune settings.)</p> <p>1 = ON – Activates speed controller autotuning. Automatically reverts to OFF.</p> <p>Procedure:</p> <p><b>Note!</b> The motor load must be connected.</p> <ul style="list-style-type: none"> <li>• Run the motor at a constant speed of 20 to 40% of the rated speed.</li> <li>• Change the autotuning parameter 2305 to ON.</li> </ul> <p>The drive:</p> <ul style="list-style-type: none"> <li>• Accelerates the motor.</li> <li>• Calculates values for proportional gain, integration time and acceleration compensation.</li> <li>• Changes parameters 2301, 2302 and 2304 to these values.</li> <li>• Resets 2305 to OFF.</li> </ul>

**Group 24: Torque Control**

This group defines variables used for torque control operation.

<b>Code</b>	<b>Description</b>
2401	<b>TORQ RAMP UP</b> Defines the torque reference ramp up time – The minimum time for the reference to increase from zero to the nominal motor torque.
2402	<b>TORQ RAMP DOWN</b> Defines the torque reference ramp down time – The minimum time for the reference to decrease from the nominal motor torque to zero.

## Group 25: Critical Speeds

This group defines up to three critical speeds or ranges of speeds that are to be avoided due, for example, to mechanical resonance problems at certain speeds.

Code	Description
2501	<p><b>CRIT SPEED SEL</b></p> <p>Sets the critical speeds function on or off. The critical speed function avoids specific speed ranges.</p> <p>0 = OFF – Disables the critical speeds function. 1 = ON – Enables the critical speeds function.</p> <p><b>Example:</b> To avoid speeds at which a fan system vibrates badly:</p> <ul style="list-style-type: none"> <li>• Determine problem speed ranges. Assume they are found to be: 18...23 Hz and 46...52 Hz.</li> <li>• Set 2501 CRIT SPEED SEL = 1.</li> <li>• Set 2502 CRIT SPEED 1 LO = 18 Hz.</li> <li>• Set 2503 CRIT SPEED 1 HI = 23 Hz.</li> <li>• Set 2504 CRIT SPEED 2 LO = 46 Hz.</li> <li>• Set 2505 CRIT SPEED 2 HI = 52 Hz.</li> </ul>
2502	<p><b>CRIT SPEED 1 LO</b></p> <p>Sets the minimum limit for critical speed range 1.</p> <ul style="list-style-type: none"> <li>• The value must be less than or equal to 2503 CRIT SPEED 1 HI.</li> <li>• Units are rpm, unless 9904 MOTOR CTRL MODE = 3 (SCALAR: SPEED), then units are Hz.</li> </ul>
2503	<p><b>CRIT SPEED 1 HI</b></p> <p>Sets the maximum limit for critical speed range 1.</p> <ul style="list-style-type: none"> <li>• The value must be greater than or equal to 2502 CRIT SPEED 1 LO.</li> <li>• Units are rpm, unless 9904 MOTOR CTRL MODE = 3 (SCALAR: SPEED), then units are Hz.</li> </ul>
2504	<p><b>CRIT SPEED 2 LO</b></p> <p>Sets the minimum limit for critical speed range 2.</p> <ul style="list-style-type: none"> <li>• See parameter 2502.</li> </ul>
2505	<p><b>CRIT SPEED 2 HI</b></p> <p>Sets the maximum limit for critical speed range 2.</p> <ul style="list-style-type: none"> <li>• See parameter 2503.</li> </ul>
2506	<p><b>CRIT SPEED 3 LO</b></p> <p>Sets the minimum limit for critical speed range 3.</p> <ul style="list-style-type: none"> <li>• See parameter 2502.</li> </ul>
2507	<p><b>CRIT SPEED 3 HI</b></p> <p>Sets the maximum limit for critical speed range 3.</p> <ul style="list-style-type: none"> <li>• See parameter 2503.</li> </ul>

**Group 26: Motor Control**

Code	Description																			
2601	<p><b>FLUX OPTIMIZATION</b></p> <p>Changes the magnitude of the flux depending on the actual load. Flux Optimization can reduce the total energy consumption and noise, and should be enabled for drives that usually operate below nominal load.</p> <p>0 = Disables the feature. 1 = Enables the feature.</p>																			
2602	<p><b>FLUX BRAKING</b></p> <p>Provides faster deceleration by raising the level of magnetization in the motor when needed, instead of limiting the deceleration ramp. By increasing the flux in the motor, the energy of the mechanical system is changed to thermal energy in the motor.</p> <p>0 = Disables the feature. 1 = Enables the feature.</p> <div style="display: flex; justify-content: space-between;"> <div style="width: 45%;"> <p>Braking Torque (%)</p> </div> <div style="width: 45%;"> <p>Rated Motor Power</p> <ul style="list-style-type: none"> <li>① 2.2 kW</li> <li>② 15 kW</li> <li>③ 37 kW</li> <li>④ 75 kW</li> <li>⑤ 250 kW</li> </ul> </div> </div>																			
2603	<p><b>IR COMP VOLT</b></p> <p>Sets the IR compensation voltage used for 0 Hz.</p> <ul style="list-style-type: none"> <li>Requires parameter 9904 MOTOR CTRL MODE = 3 (SCALAR: SPEED).</li> <li>Keep IR compensation as low as possible to prevent overheating.</li> <li>Typical IR compensation values are:</li> </ul> <table border="1" style="margin-left: 20px;"> <thead> <tr> <th colspan="6">380...480 V Units</th> </tr> <tr> <th>P<sub>N</sub> (kW)</th> <td>3</td> <td>7.5</td> <td>15</td> <td>37</td> <td>132</td> </tr> <tr> <th>IR comp (V)</th> <td>18</td> <td>15</td> <td>12</td> <td>8</td> <td>3</td> </tr> </thead></table>	380...480 V Units						P <sub>N</sub> (kW)	3	7.5	15	37	132	IR comp (V)	18	15	12	8	3	<p>IR Compensation</p> <ul style="list-style-type: none"> <li>When enabled, IR Compensation provides an extra voltage boost to the motor at low speeds. Use IR Compensation, for example, in applications that require a high breakaway torque.</li> </ul>
380...480 V Units																				
P <sub>N</sub> (kW)	3	7.5	15	37	132															
IR comp (V)	18	15	12	8	3															
2604	<p><b>IR COMP FREQ</b></p> <p>Sets the frequency at which IR compensation is 0 V (in % of motor frequency).</p>																			
2605	<p><b>U/f RATIO</b></p> <p>Selects the form for the U/f (voltage to frequency) ratio below field weakening point.</p> <p>1 = LINEAR – Preferred for constant torque applications. 2 = SQUARE – Preferred for centrifugal pump and fan applications. (Square is more silent for most operating frequencies.)</p>																			
2606	<p><b>SWITCHING FREQ</b></p> <p>Sets the switching frequency for the drive. Also see parameter 2607 SW FREQ CTRL and "Switching Frequency Derating" on page 219.</p> <ul style="list-style-type: none"> <li>Higher switching frequencies mean less noise.</li> <li>The 12 kHz switching frequency is available only if parameter 9904 MOTOR CTRL MODE = 3 (SCALAR:SPEED).</li> <li>The 12 kHz switching frequency is available only on frame sizes R1...R6</li> </ul>																			

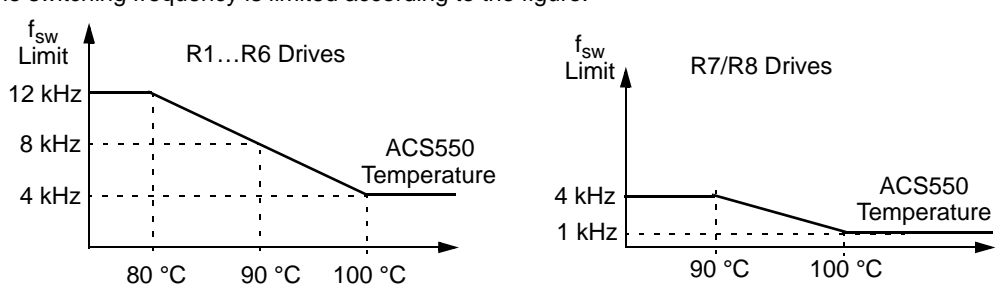
Code	Description
2607	<p><b>SW FREQ CTRL</b></p> <p>The switching frequency may be reduced if the ACS550 internal temperature rises above a limit. See Figure. This function allows the highest possible switching frequency to be used based on operating conditions. Higher switching frequency results in lower acoustic noise.</p> <p>0 = OFF – The function is disabled. 1 = ON – The switching frequency is limited according to the figure.</p>  <p>The figure contains two line graphs. The left graph is titled 'R1...R6 Drives' and shows the switching frequency limit (f<sub>sw</sub> Limit) on the y-axis and ACS550 Temperature in °C on the x-axis. The y-axis has markers at 4 kHz, 8 kHz, and 12 kHz. The x-axis has markers at 80 °C, 90 °C, and 100 °C. The graph shows a horizontal line at 12 kHz from 0 °C to 80 °C, then a downward-sloping line passing through (90 °C, 8 kHz) and (100 °C, 4 kHz). The right graph is titled 'R7/R8 Drives' and shows the switching frequency limit (f<sub>sw</sub> Limit) on the y-axis and ACS550 Temperature in °C on the x-axis. The y-axis has markers at 1 kHz and 4 kHz. The x-axis has markers at 90 °C and 100 °C. The graph shows a horizontal line at 4 kHz from 0 °C to 90 °C, then a downward-sloping line passing through (100 °C, 1 kHz).</p>
2608	<p><b>SLIP COMP RATIO</b></p> <p>Sets gain for slip compensation (in %).</p> <ul style="list-style-type: none"> <li>• A squirrel-cage motor slips under load. Increasing the frequency as the motor torque increases compensates for the slip.</li> <li>• Requires parameter 9904 MOTOR CTRL MODE = 3 (SCALAR: SPEED).</li> </ul> <p>0 = No slip compensation. 1...200 = Increasing slip compensation. 100% means full slip compensation.</p>
2609	<p><b>NOISE SMOOTHING</b></p> <p>This parameter introduces a random component to the switching frequency. Noise smoothing distributes the acoustic motor noise over a range of frequencies instead of a single tonal frequency resulting in lower peak noise intensity. The random component has an average of 0 Hz and is added to the switching frequency set by parameter 2606 (SWITCHING FREQ). This parameter has no effect if parameter 2606 = 12 kHz.</p> <p>0 = DISABLE 1 = ENABLE</p>

### Group 29: Maintenance Trig

This group contains usage levels and trigger points. When usage reaches the set trigger point, a notice displayed on the control panel signals that maintenance is due.

Code	Description
2901	<b>COOLING FAN TRIG</b> Sets the trigger point for the drive's cooling fan counter. 0.0 = NOT SEL
2902	<b>COOLING FAN ACT</b> Defines the actual value of the drive's cooling fan counter. <ul style="list-style-type: none"> <li>The parameter is reset by writing 0.0 to it.</li> </ul>
2903	<b>REVOLUTION TRIG</b> Sets the trigger point for the motor's accumulated revolutions counter. 0.0 = NOT SEL
2904	<b>REVOLUTION ACT</b> Defines the actual value of the motor's accumulated revolutions counter. <ul style="list-style-type: none"> <li>The parameter is reset by writing 0 to it.</li> </ul>
2905	<b>RUN TIME TRIG</b> Sets the trigger point for the drive's run time counter. 0.0 = NOT SEL
2906	<b>RUN TIME ACT</b> Defines the actual value of the drive's run time counter. <ul style="list-style-type: none"> <li>The parameter is reset by writing 0.0 to it.</li> </ul>
2907	<b>USER MWh TRIG</b> Sets the trigger point for the drive's accumulated power consumption (in megawatt hours) counter. 0.0 = NOT SEL
2908	<b>USER MWh ACT</b> Defines the actual value of the drive's accumulated power consumption (in megawatt hours) counter. <ul style="list-style-type: none"> <li>The parameter is reset by writing 0.0 to it.</li> </ul>

**Group 30: Fault Functions**

This group defines situations that the drive should recognize as potential faults and defines how the drive should respond if the fault is detected.

Code	Description
3001	<p><b>AI&lt;MIN FUNCTION</b></p> <p>Defines the drive response if the analog input (AI) signal drops below the fault limits and AI is used in reference chain.</p> <ul style="list-style-type: none"> <li>• 3021 AI1 FAULT LIMIT and 3022 AI2 FAULT LIMIT set the fault limits</li> </ul> <p>0 = NOT SEL – No response.                      1 = FAULT – Displays a fault (7, AI1 LOSS or 8, AI2 LOSS) and the drive coasts to stop.                      2 = CONST SP7 – Displays a warning (2006, AI1 LOSS or 2007, AI2 LOSS) and sets speed using 1208 CONST SPEED 7.                      3 = LAST SPEED – Displays a warning (2006, AI1 LOSS or 2007, AI2 LOSS) and sets speed using the last operating level. This value is the average speed over the last 10 seconds.</p> <p><b>Warning! If you select CONST SP7 or LAST SPEED, make sure that continued operation is safe when the analog input signal is lost.</b></p>
3002	<p><b>PANEL COMM ERR</b></p> <p>Defines the drive response to a control panel communication error.</p> <p>1 = FAULT – Displays a fault (10, PANEL LOSS) and the drive coasts to stop.                      2 = CONST SP7 – Displays a warning (2008, PANEL LOSS) and sets speed using 1208 CONST SPEED 7.                      3 = LAST SPEED – Displays a warning (2008, PANEL LOSS) and sets speed using the last operating level. This value is the average speed over the last 10 seconds.</p> <p><b>Warning! If you select CONST SP7 or LAST SPEED, make sure that continued operation is safe when the control panel communication is lost.</b></p>
3003	<p><b>EXTERNAL FAULT 1</b></p> <p>Defines the External Fault 1 signal input and the drive response to an external fault.</p> <p>0 = NOT SEL – External fault signal is not used.                      1 = DI1 – Defines digital input DI1 as the external fault input.                      • Activating the digital input indicates a fault. The drive displays a fault (14, EXT FAULT 1) and the drive coasts to stop.                      2...6 = DI2...DI6 – Defines digital input DI2...DI6 as the external fault input.                      • See DI1 above.                      -1 = DI1(INV) – Defines an inverted digital input DI1 as the external fault input.                      • De-activating the digital input indicates a fault. The drive displays a fault (14, EXT FAULT 1) and the drive coasts to stop.                      -2...-6 = DI2(INV)...DI6(INV) – Defines an inverted digital input DI2...DI6 as the external fault input.                      • See DI1(INV) above.</p>
3004	<p><b>EXTERNAL FAULT 2</b></p> <p>Defines the External Fault 2 signal input and the drive response to an external fault.</p> <ul style="list-style-type: none"> <li>• See parameter 3003 above.</li> </ul>
3005	<p><b>MOT THERM PROT</b></p> <p>Defines the drive response to motor overheating.</p> <p>0 = NOT SEL – No response and/or motor thermal protection not set up.                      1 = FAULT – When the calculated motor temperature exceeds 90 C, displays a warning (2010, MOT OVERTEMP). When the calculated motor temperature exceeds 110 C, displays a fault (9, MOT OVERTEMP) and the drive coasts to stop.                      2 = WARNING – When the calculated motor temperature exceeds 90 C, displays a warning (2010, MOT OVERTEMP).</p>
3006	<p><b>MOT THERM TIME</b></p> <p>Sets the motor thermal time constant for the motor temperature model.</p> <ul style="list-style-type: none"> <li>• This is the time required for the motor to reach 63% of the final temperature with steady load.</li> <li>• For thermal protection according to UL requirements for NEMA class motors, use the rule of thumb: MOT THERM TIME equals 35 times t<sub>6</sub>, where t<sub>6</sub> (in seconds) is specified by the motor manufacturer as the time that the motor can safely operate at six times its rated current.</li> <li>• The thermal time for a Class 10 trip curve is 350 s, for a Class 20 trip curve 700 s, and for a Class 30 trip curve 1050 s.</li> </ul>

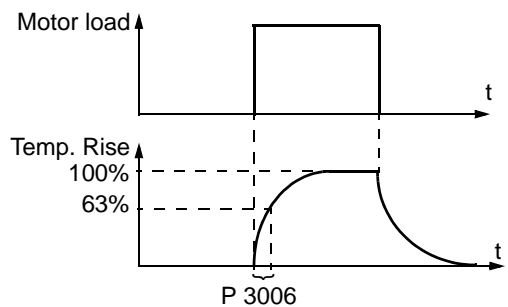

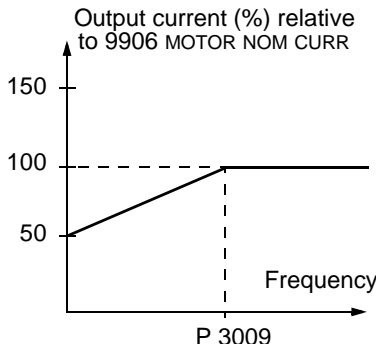
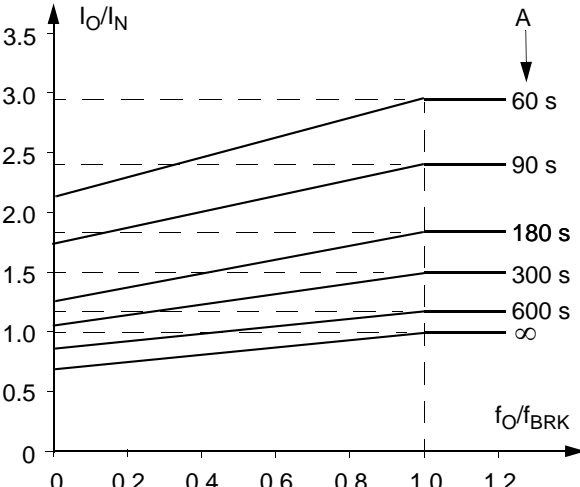
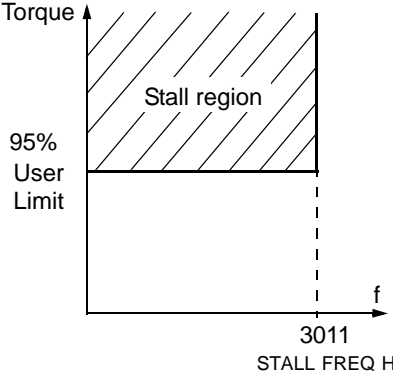

Code	Description	
3007	<b>MOT LOAD CURVE</b> Sets the maximum allowable operating load of the motor. <ul style="list-style-type: none"> <li>• When set to 100%, the maximum allowable load is equal to the value of Start-up Data parameter 9906 MOTOR NOM CURRENT.</li> <li>• Adjust the load curve level if the ambient temperature differs from nominal.</li> </ul>	
3008	<b>ZERO SPEED LOAD</b> Sets the maximum allowable current at zero speed. <ul style="list-style-type: none"> <li>• Value is relative to 9906 MOTOR NOM CURR.</li> </ul>	
3009	<b>BREAK POINT FREQ</b> Sets the break point frequency for the motor load curve.	
<p><b>Example:</b> Thermal protection trip times when parameters 3005 MOT THERM TIME, 3006 MOT LOAD CURVE and 3007 ZERO SPEED LOAD have default values.</p>  <p> <math>I_O =</math> Output current  <math>I_N =</math> Nominal motor current  <math>f_O =</math> Output frequency  <math>f_{BRK} =</math> Break point frequency  <math>A =</math> Trip time                 </p>		
3010	<b>STALL FUNCTION</b> This parameter defines the operation of the Stall function. This protection is active if the drive operates in the stall region (see figure) for the time defined by 3012 STALL TIME. The "User Limit" is defined in Group 20 by 2017 MAX TORQUE 1, 2018 MAX TORQUE 2, or the limit on the COMM input. <p>0 = NOT SEL – Stall protection is not used.</p> <p>1 = FAULT – When the drive operates in the stall region for the time set by 3012 STALL TIME:</p> <ul style="list-style-type: none"> <li>• The drive coasts to stop.</li> <li>• A fault indication is displayed.</li> </ul> <p>2 = WARNING – When the drive operates in the stall region for the time set by 3012 STALL TIME:</p> <ul style="list-style-type: none"> <li>• A warning indication is displayed.</li> <li>• The warning disappears when the drive is out of the stall region for half the time set by parameter 3012 STALL TIME.</li> </ul>	
3011	<b>STALL FREQUENCY</b> This parameter sets the frequency value for the Stall function. Refer to Figure.	
3012	<b>STALL TIME</b> This parameter sets the time value for the Stall function.	

Code	Description
3013	<p><b>UNDERLOAD FUNCTION</b></p> <p>Removal of motor load may indicate a process malfunction. The protection is activated if:</p> <ul style="list-style-type: none"> <li>• The motor torque drops below the load curve selected by parameter 3015 UNDERLOAD CURVE.</li> <li>• This condition has lasted longer than the time set by parameter 3014 UNDERLOAD TIME.</li> <li>• Output frequency is higher than 10% of the nominal frequency.</li> </ul> <p>0 = NOT SEL – Underload protection is not used.            1 = FAULT – When the protection is activated the drive coasts to stop. A fault indication is displayed.            2 = WARNING – A warning indication is displayed.</p>
3014	<p><b>UNDERLOAD TIME</b></p> <p>Time limit for underload protection.</p>
3015	<p><b>UNDERLOAD CURVE</b></p> <p>This parameter provides five selectable curves shown in the figure.</p> <ul style="list-style-type: none"> <li>• If the load drops below the set curve for longer than the time set by parameter 3014, the underload protection is activated.</li> <li>• Curves 1...3 reach maximum at the motor rated frequency set by parameter 9907 MOTOR NOM FREQ.</li> <li>• <math>T_M</math> = nominal torque of the motor.</li> <li>• <math>f_N</math> = nominal frequency of the motor.</li> </ul>
3017	<p><b>EARTH FAULT</b></p> <p>Defines the drive response if the drive detects a ground fault in the motor or motor cables. The drive monitors for ground faults while the drive is running, and while the drive is not running. Also see parameter 3023 WIRING FAULT.</p> <p>0 = DISABLE – No drive response to ground faults.            1 = ENABLE – Ground faults display fault 16 (EARTH FAULT), and (if running) the drive coasts to stop.</p>
3018	<p><b>COMM FAULT FUNC</b></p> <p>Defines the drive response if the fieldbus communication is lost.</p> <p>0 = NOT SEL – No response.            1 = FAULT – Displays a fault (28, SERIAL 1 ERR) and the drive coasts to stop.            2 = CONST SP7 – Displays a warning (2005, I/O COMM) and sets speed using 1208 CONST SPEED 7. This “alarm speed” remains active until the fieldbus writes a new reference value.            3 = LAST SPEED – Displays a warning (2005, I/O COMM) and sets speed using the last operating level. This value is the average speed over the last 10 seconds. This “alarm speed” remains active until the fieldbus writes a new reference value.</p> <p><b>Caution:</b> If you select CONST SP7, or LAST SPEED, make sure that continued operation is safe when fieldbus communication is lost.</p>
3019	<p><b>COMM FAULT TIME</b></p> <p>Sets the communication fault time used with 3018 COMM FAULT FUNC.</p> <ul style="list-style-type: none"> <li>• Brief interruptions in the fieldbus communication are not treated as faults if they are less than the COMM FAULT TIME value.</li> </ul>
3021	<p><b>AI1 FAULT LIMIT</b></p> <p>Sets a fault level for analog input 1. See 3001 AI&lt;MIN FUNCTION.</p>
3022	<p><b>AI2 FAULT LIMIT</b></p> <p>Sets a fault level for analog input 2. See 3001 AI&lt;MIN FUNCTION.</p>

Code	Description
3023	<p data-bbox="253 216 1485 247"><b>WIRING FAULT</b></p> <p data-bbox="253 247 1485 300">Defines the drive response to cross wiring faults and to ground faults detected when the drive is NOT running. When the drive is not running it monitors for:</p> <ul data-bbox="253 300 1485 415" style="list-style-type: none"><li data-bbox="253 300 1485 352">• Improper connections of input power to the drive output (the drive can display fault 35, OUTPUT WIRING if improper connections are detected).</li><li data-bbox="253 352 1485 415">• Ground faults (the drive can display fault 16, EARTH FAULT if a ground fault is detected). Also, see parameter 3017 EARTH FAULT.</li></ul> <p data-bbox="253 415 1485 447">0 = DISABLE – No drive response to either of the above monitoring results.</p> <p data-bbox="253 447 1485 462">1 = ENABLE – The drive displays faults when this monitoring detects problems.</p>

### Group 31: Automatic Reset

This group defines conditions for automatic resets. An automatic reset occurs after a particular fault is detected. The drive holds for a set delay time, then automatically restarts. You can limit the number of resets in a specified time period, and you can set up automatic resets for a variety of faults.

Code	Description
3101	<p><b>NR OF TRIALS</b></p> <p>Sets the number of allowed automatic resets within a trial period defined by 3102 TRIAL TIME.</p> <ul style="list-style-type: none"> <li>If the number of automatic resets exceeds this limit (within the trial time), the drive prevents additional automatic resets and remains stopped.</li> <li>Starting then requires a successful reset performed from the control panel or from a source selected by 1604 FAULT RESET SEL.</li> </ul>
3102	<p><b>TRIAL TIME</b></p> <p>Sets the time period used for counting and limiting the number of resets.</p> <ul style="list-style-type: none"> <li>See 3101 NR OF TRIALS.</li> </ul>
3103	<p><b>DELAY TIME</b></p> <p>Sets the delay time between a fault detection and attempted drive restart.</p> <ul style="list-style-type: none"> <li>If DELAY TIME = zero, the drive resets immediately.</li> </ul>
3104	<p><b>AR OVERCURRENT</b></p> <p>Sets the automatic reset for the overcurrent function on or off.</p> <p>0 = DISABLE – Disables automatic reset. 1 = ENABLE – Enables automatic reset.</p> <ul style="list-style-type: none"> <li>Automatically resets the fault (OVERCURRENT) after the delay set by 3103 DELAY TIME, and the drive resumes normal operation.</li> </ul>
3105	<p><b>AR OVERVOLTAGE</b></p> <p>Sets the automatic reset for the overvoltage function on or off.</p> <p>0 = DISABLE – Disables automatic reset. 1 = ENABLE – Enables automatic reset.</p> <ul style="list-style-type: none"> <li>Automatically resets the fault (DC OVERVOLT) after the delay set by 3103 DELAY TIME, and the drive resumes normal operation.</li> </ul>
3106	<p><b>AR UNDERVOLTAGE</b></p> <p>Sets the automatic reset for the undervoltage function on or off.</p> <p>0 = DISABLE – Disables automatic reset. 1 = ENABLE – Enables automatic reset.</p> <ul style="list-style-type: none"> <li>Automatically resets the fault (DC UNDERVOLTAGE) after the delay set by 3103 DELAY TIME, and the drive resumes normal operation.</li> </ul>
3107	<p><b>AR AI&lt;MIN</b></p> <p>Sets the automatic reset for the analog input less than minimum value function on or off.</p> <p>0 = DISABLE – Disables automatic reset. 1 = ENABLE – Enables automatic reset.</p> <ul style="list-style-type: none"> <li>Automatically resets the fault (AI&lt;MIN) after the delay set by 3103 DELAY TIME, and the drive resumes normal operation.</li> </ul> <p><b>Warning! When the analog input signal is restored, the drive may restart, even after a long stop. Make sure that automatic, long delayed starts will not cause physical injury and/or damage equipment.</b></p>
3108	<p><b>AR EXTERNAL FAULT</b></p> <p>Sets the automatic reset for external faults function on or off.</p> <p>0 = DISABLE – Disables automatic reset. 1 = ENABLE – Enables automatic reset.</p> <ul style="list-style-type: none"> <li>Automatically resets the fault (EXTERNAL FAULT 1 or EXTERNAL FAULT 2) after the delay set by 3103 DELAY TIME, and the drive resumes normal operation.</li> </ul>

**Example:** Three faults have occurred in the trial time. The last is reset only if the value for 3101 NR OF TRIALS is 3 or more.

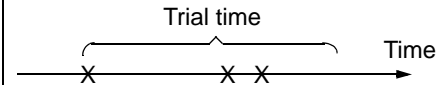

x = Automatic reset

### Group 32: Supervision

This group defines supervision for up to three signals from Group 01, Operating Data. Supervision monitors a specified parameter and energizes a relay output if the parameter passes a defined limit. Use Group 14, Relay Outputs, to define the relay and whether the relay activates when the signal is too low or too high.

Code	Description
3201	<p><b>SUPERV 1 PARAM</b></p> <p>Selects the first supervised parameter.</p> <ul style="list-style-type: none"> <li>Must be a parameter number from Group 01 Operating Data.</li> <li>If the supervised parameter passes a limit, a relay output is energized.</li> <li>The supervision limits are defined in this group.</li> <li>The relay outputs are defined in Group 14 Relay Outputs (definition also specifies which supervision limit is monitored).</li> </ul> <p><b>LO ≤ HI</b></p> <p>Operating data supervision using relay outputs, when LO ≤ HI.</p> <ul style="list-style-type: none"> <li>Case A = Parameter 1401 RELAY OUTPUT 1 (or 1402 RELAY OUTPUT 2, etc.) value is SUPRV1 OVER or SUPRV 2 OVER. Use for monitoring when/if the supervised signal exceeds a given limit. The relay remains active until the supervised value drops below the low limit.</li> <li>Case B = Parameter 1401 RELAY OUTPUT 1 (or 1402 RELAY OUTPUT 2, etc.) value is SUPRV 1 UNDER or SUPRV 2 UNDER. Use for monitoring when/if the supervised signal falls below a given limit. The relay remains active until the supervised value rises above the high limit.</li> </ul> <p><b>LO &gt; HI</b></p> <p>Operating data supervision using relay outputs, when LO &gt; HI. The lowest limit (HI 3203) is active initially, and remains active until the supervised parameter goes above the highest limit (LO 3202), making that limit the active limit. That limit remains active until the supervised parameter goes below the lowest limit (HI 3203), making that limit active.</p> <ul style="list-style-type: none"> <li>Case A = Parameter 1401 RELAY OUTPUT 1 (or 1402 RELAY OUTPUT 2, etc.) value is SUPRV1 OVER or SUPRV2 OVER. Initially the relay is de-energized. It is energized whenever the supervised parameter goes above the active limit.</li> <li>Case B = Parameter 1402 RELAY OUTPUT 1 (or 1402 RELAY OUTPUT 2, etc.) value is SUPRV1 UNDER or SUPRV2 UNDER. Initially the relay is energized. It is de-energized whenever the supervised parameter goes below the active limit.</li> </ul>
3202	<p><b>SUPERV 1 LIM LO</b></p> <p>Sets the low limit for the first supervised parameter. See 3201 SUPERV 1 PARAM above.</p>
3203	<p><b>SUPERV 1 LIM HI</b></p> <p>Sets the high limit for the first supervised parameter. See 3201 SUPERV 1 PARAM above.</p>
3204	<p><b>SUPERV 2 PARAM</b></p> <p>Selects the second supervised parameter. See 3201 SUPERV 1 PARAM above.</p>
3205	<p><b>SUPERV 2 LIM LO</b></p> <p>Sets the low limit for the second supervised parameter. See 3204 SUPERV 2 PARAM above.</p>
3206	<p><b>SUPERV 2 LIM HI</b></p> <p>Sets the high limit for the second supervised parameter. See 3204 SUPERV 2 PARAM above.</p>
3207	<p><b>SUPERV 3 PARAM</b></p> <p>Selects the third supervised parameter. See 3201 SUPERV 1 PARAM above.</p>

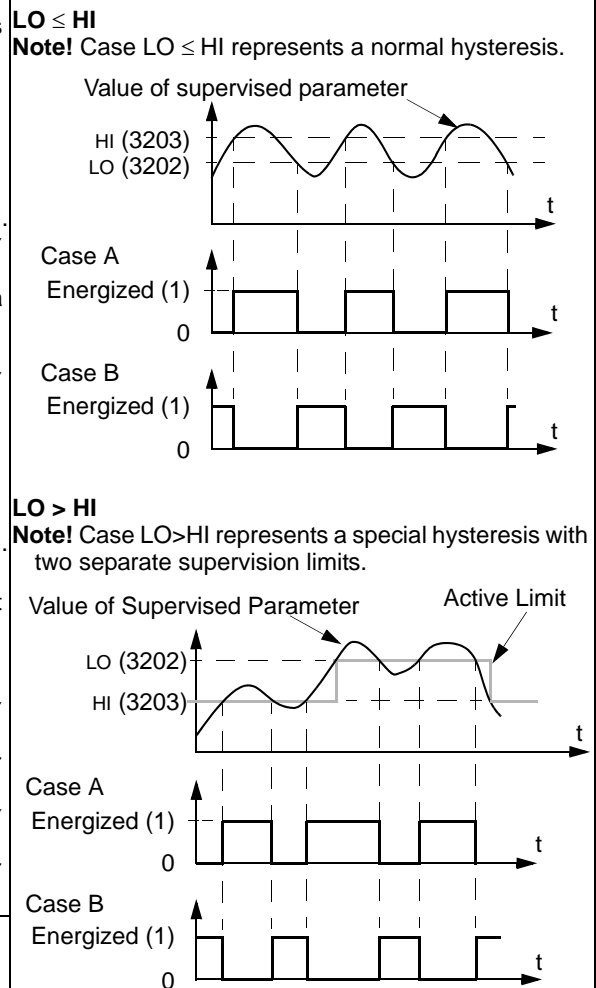

Code	Description
3208	<b>SUPERV 3 LIM LO</b> Sets the low limit for the third supervised parameter. See 3207 SUPERV 3 PARAM above.
3209	<b>SUPERV 3 LIM HI</b> Sets the high limit for the third supervised parameter. See 3207 SUPERV 3 PARAM above.

**Group 33: Information**

This group provides access to information about the drive's current programs: versions and test date.

<b>Code</b>	<b>Description</b>
3301	<b>FW VERSION</b> Contains the version of the drive's firmware.
3302	<b>LP VERSION</b> Contains the version of the loading package.
3303	<b>TEST DATE</b> Contains the test date (yy.ww).
3304	<b>DRIVE RATING</b> Indicates the drive's current and voltage rating. The format is XXXY, where: <ul style="list-style-type: none"> <li>• XXX = The nominal current rating of the drive in amps. If present, an "A" indicates a decimal point in the rating for the current. For example XXX = 8A8 indicates a nominal current rating of 8.8 Amps.</li> <li>• Y = The voltage rating of the drive, where Y = : <ul style="list-style-type: none"> <li>• 2 indicates a 208...240 Volt rating.</li> <li>• 4 indicates a 380...480 Volt rating.</li> <li>• 6 indicates a 500...600 Volt rating.</li> </ul> </li> </ul>

### Group 34: Panel Display Process Variables

This group defines the content for control panel display (middle area), when the control panel is in the output mode.

Code	Description																																																																																				
3401	<p><b>SIGNAL1 PARAM</b></p> <p>Selects the first parameter (by number) displayed on the control panel.</p> <ul style="list-style-type: none"> <li>Definitions in this group define display content when the control panel is in the control mode.</li> <li>Any Group 01 parameter number can be selected.</li> <li>Using the following parameters, the display value can be scaled, converted to convenient units, and/or displayed as a bar graph.</li> <li>The figure identifies selections made by parameters in this group.</li> </ul> <p>100 = not selected – First parameter not displayed.                      101...199 = Displays parameter 0101...0199. If parameter does not exist, the display shows "n.a."</p>																																																																																				
3402	<p><b>SIGNAL1 MIN</b></p> <p>Defines the minimum expected value for the first display parameter. Use parameters 3402, 3403, 3406, and 3407, for example to convert a Group 01 parameter, such as 0102 SPEED (in rpm) to the speed of a conveyor driven by the motor (in ft/min). For such a conversion, the source values in the figure are the min. and max. motor speed, and the display values are the corresponding min. and max. conveyor speed. Use parameter 3405 to select the proper units for the display. Note! Selecting units does not convert values.</p>																																																																																				
3403	<p><b>SIGNAL1 MAX</b></p> <p>Defines the maximum expected value for the first display parameter.</p>																																																																																				
3404	<p><b>OUTPUT1 DSP FORM</b></p> <p>Defines the decimal point location for the first display parameter.</p> <p>1...7 – Defines the decimal point location.</p> <ul style="list-style-type: none"> <li>Enter the number of digits desired to the right of the decimal point.</li> <li>See table for example using pi (3.14159).</li> </ul> <p>8 = BAR METER – Specifies a bar meter display.                      9 = DIRECT – Decimal point location and units of measure are identical to the source signal. See Group 01 parameter listing in "Complete Parameter List" for resolution (which indicates the decimal point location) and the units of measure.</p> <table border="1"> <thead> <tr> <th>3404 Value</th> <th>Display</th> <th>Range</th> </tr> </thead> <tbody> <tr> <td>0</td> <td>± 3</td> <td rowspan="3">-32768...+32767 (Signed)</td> </tr> <tr> <td>1</td> <td>± 3.1</td> </tr> <tr> <td>2</td> <td>± 3.14</td> </tr> <tr> <td>3</td> <td>± 3.142</td> <td rowspan="5">0...65535 (Unsigned)</td> </tr> <tr> <td>4</td> <td>3</td> </tr> <tr> <td>5</td> <td>3.1</td> </tr> <tr> <td>6</td> <td>3.14</td> </tr> <tr> <td>7</td> <td>3.142</td> </tr> </tbody> </table>	3404 Value	Display	Range	0	± 3	-32768...+32767 (Signed)	1	± 3.1	2	± 3.14	3	± 3.142	0...65535 (Unsigned)	4	3	5	3.1	6	3.14	7	3.142																																																															
3404 Value	Display	Range																																																																																			
0	± 3	-32768...+32767 (Signed)																																																																																			
1	± 3.1																																																																																				
2	± 3.14																																																																																				
3	± 3.142	0...65535 (Unsigned)																																																																																			
4	3																																																																																				
5	3.1																																																																																				
6	3.14																																																																																				
7	3.142																																																																																				
3405	<p><b>OUTPUT1 UNIT</b></p> <p>Selects the units used with the first display parameter.</p> <table border="0"> <tr> <td>0 = NOT SEL</td> <td>9 = °C</td> <td>18 = MWh</td> <td>27 = ft</td> <td>36 = l/s</td> <td>45 = Pa</td> <td>54 = lb/m</td> <td>63 = Mrev</td> </tr> <tr> <td>1 = A</td> <td>10 = lb ft</td> <td>19 = m/s</td> <td>28 = MGD</td> <td>37 = l/min</td> <td>46 = GPS</td> <td>55 = lb/h</td> <td>64 = d</td> </tr> <tr> <td>2 = V</td> <td>11 = mA</td> <td>20 = m<sup>3</sup>/h</td> <td>29 = inHg</td> <td>38 = l/h</td> <td>47 = gal/s</td> <td>56 = FPS</td> <td>65 = inWC</td> </tr> <tr> <td>3 = Hz</td> <td>12 = mV</td> <td>21 = dm<sup>3</sup>/s</td> <td>30 = FPM</td> <td>39 = m<sup>3</sup>/s</td> <td>48 = gal/m</td> <td>57 = ft/s</td> <td>66 = m/min</td> </tr> <tr> <td>4 = %</td> <td>13 = kW</td> <td>22 = bar</td> <td>31 = kb/s</td> <td>40 = m<sup>3</sup>/m</td> <td>49 = gal/h</td> <td>58 = inH<sub>2</sub>O</td> <td></td> </tr> <tr> <td>5 = s</td> <td>14 = W</td> <td>23 = kPa</td> <td>32 = kHz</td> <td>41 = kg/s</td> <td>50 = ft<sup>3</sup>/s</td> <td>59 = in wg</td> <td></td> </tr> <tr> <td>6 = h</td> <td>15 = kWh</td> <td>24 = GPM</td> <td>33 = Ohm</td> <td>42 = kg/m</td> <td>51 = ft<sup>3</sup>/m</td> <td>60 = ft wg</td> <td></td> </tr> <tr> <td>7 = rpm</td> <td>16 = °F</td> <td>25 = PSI</td> <td>34 = ppm</td> <td>43 = kg/h</td> <td>52 = ft<sup>3</sup>/h</td> <td>61 = lbsi</td> <td></td> </tr> <tr> <td>8 = kh</td> <td>17 = hp</td> <td>26 = CFM</td> <td>35 = pps</td> <td>44 = mbar</td> <td>53 = lb/s</td> <td>62 = ms</td> <td></td> </tr> </table> <table border="0"> <tr> <td>117 = %ref</td> <td>119 = %dev</td> <td>121 = % SP</td> <td>123 = Iout</td> <td>125 = Fout</td> <td>127 = Vdc</td> </tr> <tr> <td>118 = %act</td> <td>120 = %LD</td> <td>122 = %FBK</td> <td>124 = Vout</td> <td>126 = Tout</td> <td></td> </tr> </table>	0 = NOT SEL	9 = °C	18 = MWh	27 = ft	36 = l/s	45 = Pa	54 = lb/m	63 = Mrev	1 = A	10 = lb ft	19 = m/s	28 = MGD	37 = l/min	46 = GPS	55 = lb/h	64 = d	2 = V	11 = mA	20 = m <sup>3</sup> /h	29 = inHg	38 = l/h	47 = gal/s	56 = FPS	65 = inWC	3 = Hz	12 = mV	21 = dm <sup>3</sup> /s	30 = FPM	39 = m <sup>3</sup> /s	48 = gal/m	57 = ft/s	66 = m/min	4 = %	13 = kW	22 = bar	31 = kb/s	40 = m <sup>3</sup> /m	49 = gal/h	58 = inH <sub>2</sub> O		5 = s	14 = W	23 = kPa	32 = kHz	41 = kg/s	50 = ft <sup>3</sup> /s	59 = in wg		6 = h	15 = kWh	24 = GPM	33 = Ohm	42 = kg/m	51 = ft <sup>3</sup> /m	60 = ft wg		7 = rpm	16 = °F	25 = PSI	34 = ppm	43 = kg/h	52 = ft <sup>3</sup> /h	61 = lbsi		8 = kh	17 = hp	26 = CFM	35 = pps	44 = mbar	53 = lb/s	62 = ms		117 = %ref	119 = %dev	121 = % SP	123 = Iout	125 = Fout	127 = Vdc	118 = %act	120 = %LD	122 = %FBK	124 = Vout	126 = Tout	
0 = NOT SEL	9 = °C	18 = MWh	27 = ft	36 = l/s	45 = Pa	54 = lb/m	63 = Mrev																																																																														
1 = A	10 = lb ft	19 = m/s	28 = MGD	37 = l/min	46 = GPS	55 = lb/h	64 = d																																																																														
2 = V	11 = mA	20 = m <sup>3</sup> /h	29 = inHg	38 = l/h	47 = gal/s	56 = FPS	65 = inWC																																																																														
3 = Hz	12 = mV	21 = dm <sup>3</sup> /s	30 = FPM	39 = m <sup>3</sup> /s	48 = gal/m	57 = ft/s	66 = m/min																																																																														
4 = %	13 = kW	22 = bar	31 = kb/s	40 = m <sup>3</sup> /m	49 = gal/h	58 = inH <sub>2</sub> O																																																																															
5 = s	14 = W	23 = kPa	32 = kHz	41 = kg/s	50 = ft <sup>3</sup> /s	59 = in wg																																																																															
6 = h	15 = kWh	24 = GPM	33 = Ohm	42 = kg/m	51 = ft <sup>3</sup> /m	60 = ft wg																																																																															
7 = rpm	16 = °F	25 = PSI	34 = ppm	43 = kg/h	52 = ft <sup>3</sup> /h	61 = lbsi																																																																															
8 = kh	17 = hp	26 = CFM	35 = pps	44 = mbar	53 = lb/s	62 = ms																																																																															
117 = %ref	119 = %dev	121 = % SP	123 = Iout	125 = Fout	127 = Vdc																																																																																
118 = %act	120 = %LD	122 = %FBK	124 = Vout	126 = Tout																																																																																	
3406	<p><b>OUTPUT1 MIN</b></p> <p>Sets the minimum value displayed for the first display parameter.</p>																																																																																				
3407	<p><b>OUTPUT1 MAX</b></p> <p>Sets the maximum value displayed for the first display parameter.</p>																																																																																				



<b>Code</b>	<b>Description</b>
3408	<b>SIGNAL 2 PARAM</b> Selects the second parameter (by number) displayed on the control panel. See parameter 3401.
3409	<b>SIGNAL 2 MIN</b> Defines the minimum expected value for the second display parameter. See parameter 3402.
3410	<b>SIGNAL 2 MAX</b> Defines the maximum expected value for the second display parameter. See parameter 3403.
3411	<b>OUTPUT 2 DSP FORM</b> Defines the decimal point location for the second display parameter. See parameter 3404.
3412	<b>OUTPUT 2 DSP UNIT</b> Selects the units used with the second display parameter. See parameter 3405.
3413	<b>OUTPUT 2 MIN</b> Sets the minimum value displayed for the second display parameter. See parameter 3406.
3414	<b>OUTPUT 2 MAX</b> Sets the maximum value displayed for the second display parameter. See parameter 3407.
3415	<b>SIGNAL 3 PARAM</b> Selects the third parameter (by number) displayed on the control panel. See parameter 3401.
3416	<b>SIGNAL 3 MIN</b> Defines the minimum expected value for the third display parameter. See parameter 3402.
3417	<b>SIGNAL 3 MAX</b> Defines the maximum expected value for the third display parameter. See parameter 3403.
3418	<b>OUTPUT 3 DSP FORM</b> Defines the decimal point location for the third display parameter. See parameter 3404.
3419	<b>OUTPUT 3 DSP UNIT</b> Selects the units used with the third display parameter. See parameter 3405.
3420	<b>OUTPUT 3 MIN</b> Sets the minimum value displayed for the third display parameter. See parameter 3406.
3421	<b>OUTPUT 3 MAX</b> Sets the maximum value displayed for the third display parameter. See parameter 3407.

**Group 35: Motor Temp Meas**

This group defines the detection and reporting for a particular potential fault – motor overheating, as detected by a temperature sensor. Typical connections are defined below.

One Sensor

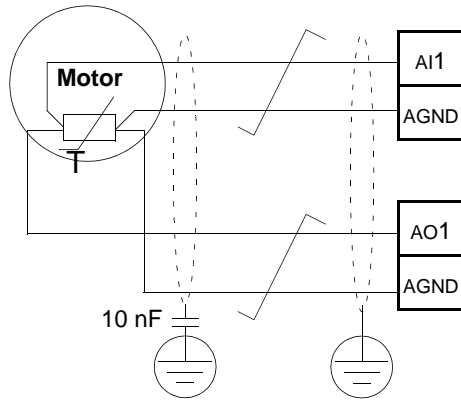

Three Sensors

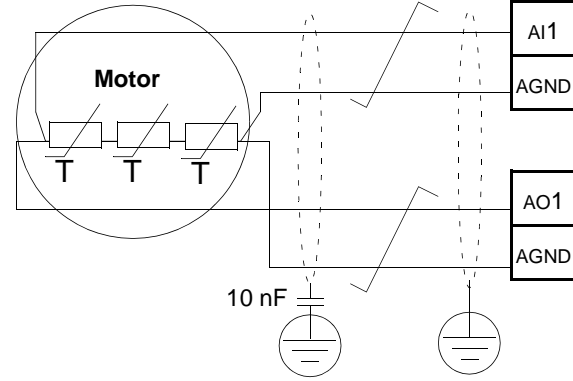

**Warning!** IEC 60664 requires double or reinforced insulation between live parts and the surface of accessible parts of electrical equipment which are either non-conductive or conductive but not connected to the protective earth.

To fulfil this requirement, connect a thermistor (and other similar components) to the drive's control terminals using any of these alternatives:

- Separate the thermistor from live parts of the motor with double reinforced insulation.
- Protect all circuits connected to the drive's digital and analog inputs. Protect against contact, and insulate from other low voltage circuits with basic insulation (rated for the same voltage level as the drive's main circuit).
- Use an external thermistor relay. The relay insulation must be rated for the same voltage level as the drive's main circuit.

The figure below shows alternate thermistor connections. At the motor end the cable shield should be earthed through a 10 nF capacitor. If this is not possible, leave the shield unconnected.

**Thermistor Relay: Thermistor (0) or (1)**

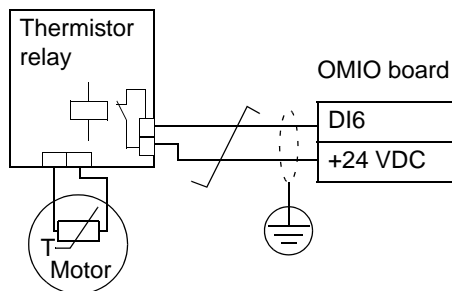

**Thermistor (0)**

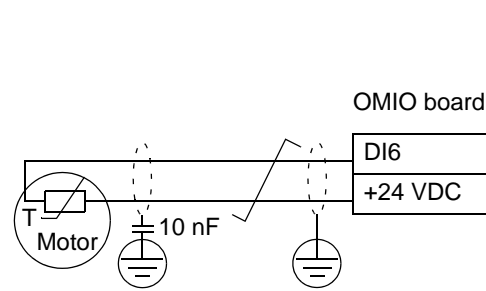

For other faults, or for anticipating motor overheating using a model, see Group 30: Fault Functions.

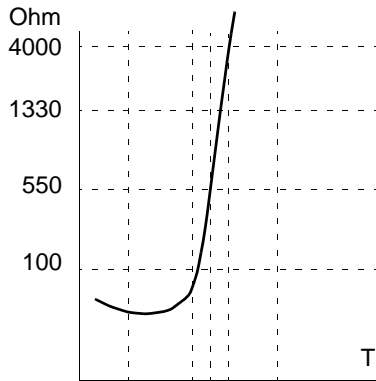
Code	Description						
3501	<p><b>SENSOR TYPE</b>                      Identifies the type of motor temperature sensor used, PT100 (°C) or PTC (ohms).                      See parameters 1501 and 1507.                      0 = NONE                      1 = 1 x PT100 – Sensor configuration uses one PT 100 sensor.                      • Analog output AO1 or AO2 feeds constant current through the sensor.                      • The sensor resistance increases as the motor temperature rises, as does the voltage over the sensor.                      • The temperature measurement function reads the voltage through analog input AI1 or AI2 and converts it to degrees centigrade.                      2 = 2 x PT100 – Sensor configuration uses two PT 100 sensors.                      • Operation is the same as for above 1 x PT100.                      3 = 3 x PT100 – Sensor configuration uses three PT 100 sensors.                      • Operation is the same as for above 1 x PT100.                      4 = PTC – Sensor configuration uses PTC.                      • The analog output feeds a constant current through the sensor.                      • The resistance of the sensor increases sharply as the motor temperature rises over the PTC reference temperature (<math>T_{ref}</math>), as does the voltage over the resistor. The temperature measurement function reads the voltage through analog input AI1 and converts it into ohms.                      • The figure shows typical PTC sensor resistance values as a function of the motor operating temperature.</p> <table border="1" data-bbox="300 940 737 1033"> <thead> <tr> <th>Temperature</th> <th>Resistance</th> </tr> </thead> <tbody> <tr> <td>Normal</td> <td>0 ... 1.5 kohm</td> </tr> <tr> <td>Excessive</td> <td><math>\geq 4</math> kohm</td> </tr> </tbody> </table>  <p>5 = THERMISTOR (0) – Sensor configuration uses a thermistor.                      • Motor thermal protection is activated through a digital input. Connect either a PTC sensor or a normally closed thermistor relay to a digital input. The drive reads the digital input states as shown in the above table.                      • When the digital input is '0' the motor is overheated.                      • See the figures in the introduction to this Group.                      6 = THERMISTOR (1) – Sensor configuration uses a thermistor.                      • Motor thermal protection is activated through a digital input. Connect a normally open thermistor relay to a digital input. The drive reads the digital input states as shown in the above table.                      • When the digital input is '1' the motor is overheated.                      • See the figures in the introduction to this Group.</p>	Temperature	Resistance	Normal	0 ... 1.5 kohm	Excessive	$\geq 4$ kohm
Temperature	Resistance						
Normal	0 ... 1.5 kohm						
Excessive	$\geq 4$ kohm						
3502	<p><b>INPUT SELECTION</b>                      Defines the input used for the temperature sensor.                      1 = AI1 – PT100 and PTC.                      2 = AI2 – PT100 and PTC.                      3...8 = DI1...DI6 – Thermistor</p>						
3503	<p><b>ALARM LIMIT</b>                      Defines the alarm limit for motor temperature measurement.                      • At motor temperatures above this limit, the drive displays an alarm (2010, MOTOR OVERTEMP)                      For thermistors:                      0 = de-activated                      1 = activated</p>						
3504	<p><b>FAULT LIMIT</b>                      Defines the fault limit for motor temperature measurement.                      • At motor temperatures above this limit, the drive displays a fault (9, MOTOR OVERTEMP) and stops the drive.                      For thermistors:                      0 = de-activated                      1 = activated</p>						

**Group 36: Timer Functions**

This group defines the timer functions. The timer functions include:

- Four daily start and stop times.
- Four weekly start, stop and boost times.
- Four timers for collecting selected periods together.

A timer can be connected to multiple time periods and a time period can be in multiple timers.

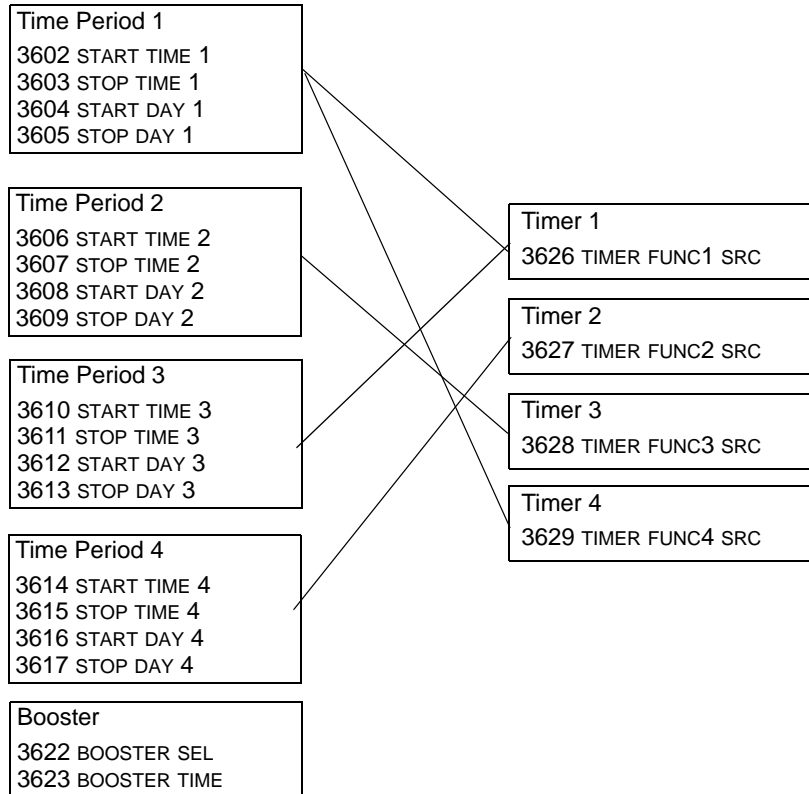

A parameter can be connected to only one timer.

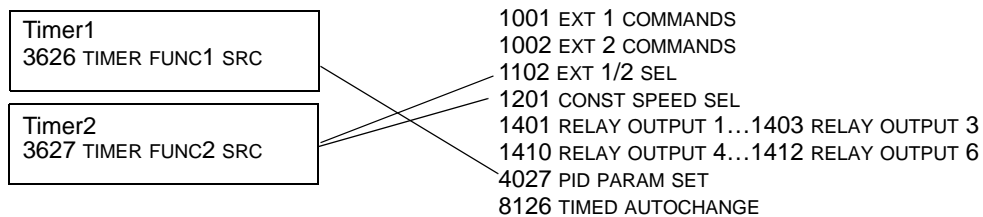

Code	Description
3601	<p><b>TIMERS ENABLE</b></p> <p>Selects the source for the timer enable signal.</p> <p>0 = NOT SEL – Timed functions are disabled.</p> <p>1 = DI1– Defines digital input DI1 as the timed function enable signal.</p> <ul style="list-style-type: none"> <li>The digital input must be activated to enable the timed function.</li> </ul> <p>2...6 = DI2...DI6 – Defines digital input DI2...DI6 as the timed function enable signal.</p> <p>7 = ENABLED – Timed functions are enabled.</p> <p>-1 = DI1(INV) – Defines an inverted digital input DI1 as the timed function enable signal.</p> <ul style="list-style-type: none"> <li>This digital input must be de-activated to enable the timed function.</li> <li>-2...-6 = DI2(INV)...DI6(INV) – Defines an inverted digital input DI2...DI6 as the timed function enable signal.</li> </ul>
3602	<p><b>START TIME 1</b></p> <p>Defines the daily start time. 20:30:00</p> <ul style="list-style-type: none"> <li>The time can be changed in steps of 2 seconds.</li> <li>If parameter value is 07:00:00, then the timer is activated at 7 a.m.</li> <li>The figure shows multiple timers on different weekdays.</li> </ul> <p>17:00:00</p> <p>15:00:00</p> <p>13:00:00</p> <p>12:00:00</p> <p>10:30:00</p> <p>09:00:00</p> <p>00:00:00</p> <p>Mon Tue Wed Thu Fri Sat Sun</p>
3603	<p><b>STOP TIME 1</b></p> <p>Defines the daily stop time.</p> <ul style="list-style-type: none"> <li>The time can be in steps of 2 seconds.</li> <li>If the parameter value is 09:00:00, then the timer is deactivated at 9 a.m.</li> </ul>
3604	<p><b>START DAY 1</b></p> <p>Defines the weekly start day.</p> <p>1 = Monday</p> <p>...</p> <p>7 = Sunday.</p> <ul style="list-style-type: none"> <li>If parameter value is 1, then timer 1 weekly is active from Monday midnight (00:00:00).</li> </ul>
3605	<p><b>STOP DAY 1</b></p> <p>Defines weekly stop day.</p> <p>1 = Monday</p> <p>...</p> <p>7 = Sunday.</p> <ul style="list-style-type: none"> <li>If parameter value is 5, then timer 1 weekly is deactivated on Friday midnight (23:59:58).</li> </ul>
3606	<p><b>START TIME 2</b></p> <p>Defines timer2 daily start time.</p> <ul style="list-style-type: none"> <li>See parameter 3602</li> </ul>
3607	<p><b>STOP TIME 2</b></p> <p>Defines timer2 daily stop time.</p> <ul style="list-style-type: none"> <li>See parameter 3603</li> </ul>
3608	<p><b>START DAY 2</b></p> <p>Defines timer 2 weekly start day.</p> <ul style="list-style-type: none"> <li>See parameter 3604</li> </ul>
3609	<p><b>STOP DAY 2</b></p> <p>Defines timer 2 weekly stop day.</p> <ul style="list-style-type: none"> <li>See parameter 3605</li> </ul>
3610	<p><b>START TIME 3</b></p> <p>Defines timer 3 daily start time.</p> <ul style="list-style-type: none"> <li>See parameter 3602</li> </ul>

Code	Description
3611	<p><b>STOP TIME 3</b>                      Defines timer 3 daily stop time.                      • See parameter 3603</p>
3612	<p><b>START DAY 3</b>                      Defines timer 3 weekly start day.                      • See parameter 3604</p>
3613	<p><b>STOP DAY 3</b>                      Defines timer 3 weekly stop day.                      • See parameter 3605</p>
3614	<p><b>START TIME 4</b>                      Defines timer 4 daily start time.                      • See parameter 3602</p>
3615	<p><b>STOP TIME 4</b>                      Defines timer 4 daily stop time.                      • See parameter 3603</p>
3616	<p><b>START DAY 4</b>                      Defines timer 4 weekly start day.                      • See parameter 3604</p>
3617	<p><b>STOP DAY 4</b>                      Defines timer 4 weekly stop day.                      • See parameter 3605</p>
3622	<p><b>BOOSTER SEL</b>                      Selects the source for the booster signal.                      0 = NOT SEL – Booster signal is disabled.                      1 = DI1 – Defines DI1 as the booster signal.                      2...6 = DI2...DI6 – Defines DI2...DI6 as the booster signal.                      -1 = DI1(INV) – Defines an inverted digital input DI1 as the booster signal.                      -2...-6 = DI2(INV)...DI6(INV) – Defines an inverted digital input DI2...DI6 as the booster signal.</p>
3623	<p><b>BOOSTER TIME</b>                      Defines the booster ON time. Time is started when booster sel signal is released. If parameter range is 01:30:00, then booster is active for 1 hour and 30 minutes after activation DI is released.</p>
3626	<p><b>TIMER FUNC1 SRC</b>                      Defines the time periods used by the timer.                      0 = NOT SEL – No time periods have been selected.                      1 = P1 – Time Period1 selected in the timer.                      2 = P2 – Time Period2 selected in the timer.                      3 = P2 + P1 – Time Periods 1 and 2 selected in the timer.                      4 = P3 – Time Period3 selected in the timer.                      5 = P3 + P1 – Time Periods 1 and 3 selected in the timer.                      6 = P3 + P2 – Time Periods 2 and 3 selected in the timer.                      7 = P3 + P2 + P1 – Time Periods 1, 2 and 3 selected in the timer.                      8 = P4 – Time Period4 selected in the timer.                      9 = P4 + P1 – Time Periods 4 and 1 selected in the timer.                      10 = P4 + P2 – Time Periods 4 and 2 selected in the timer.</p>

Code	Description
	11 = P4 + P2 + P1 – Time Periods 4, 2 and 1 selected in the timer. 12 = P4 + P3 – Time Periods 4 and 3 selected in the timer. 13 = P4 + P3 + P1 – Time Periods 4, 3 and 1 selected in the timer. 14 = P4 + P3 + P2 – Time Periods 4, 3 and 2 selected in the timer. 15 = P4 + P3 + P2 + P1 – Time Periods 4, 3, 2 and 1 selected in the timer. 16 = BOOSTER (B) – Booster selected in the timer. 17 = B + P1 – Booster and Time Period 1 selected in the timer. 18 = B + P2 – Booster and Time Period 2 selected in the timer. 19 = B + P2 + P1 – Booster and Time Periods 1 and 2 selected in the timer. 20 = B + P3 – Booster and Time Period3 selected in the timer. 21 = B + P3 + P1 – Booster and Time Periods 3 and 1 selected in the timer. 22 = B + P3 + P2 – Booster and Time Periods 3 and 2 selected in the timer. 23 = B + P3 + P2 + P1 – Booster and Time Periods 3, 2 and 1 selected in the timer. 24 = B + P4 – Booster and Time Period4 selected in the timer. 25 = B + P4 + P1 – Booster and Time Period4 and Time Period1 selected in the timer. 26 = B + P4 + P2 – Booster and Time Periods 4 and 2 selected in the timer. 27 = B + P4 + P2 + P1 – Booster and Time Periods 4, 2 and 1 selected in the timer. 28 = B + P4 + P3 – Booster and Time Periods 4, 3 29 = B + P4 + P3 + P1 – Booster and Time Periods 4, 3 and 1 selected in the timer. 30 = B + P4 + P3 + P2 – Booster and Time Periods 4, 3 and 2 selected. 31 = B + P4 + P3 + P2 + P1 – Booster and Time Periods 4, 3, 2 and 1 selected.
3627	<b>TIMER FUNC2 SRC</b> • See parameter 3626.
3628	<b>TIMER FUNC3 SRC</b> • See parameter 3626.
3629	<b>TIMER FUNC4 SRC</b> • See parameter 3626.

**Group 40: Process PID Set 1**

This group defines a set of parameters used with the Process PID (PID1) controller. Typically only parameters in this group are needed.

*PID Controller – Basic Set-up*

In PID control mode, the drive compares a reference signal (setpoint) to an actual signal (feedback), and automatically adjusts the speed of the drive to match the two signals. The difference between the two signals is the error value.

Typically PID control mode is used, when the speed of a motor needs to be controlled based on pressure, flow or temperature. In most cases – when there is only 1 transducer signal wired to the ACS550 – only parameter group 40 is needed.

The following is a schematic of setpoint/feedback signal flow using parameter group 40.

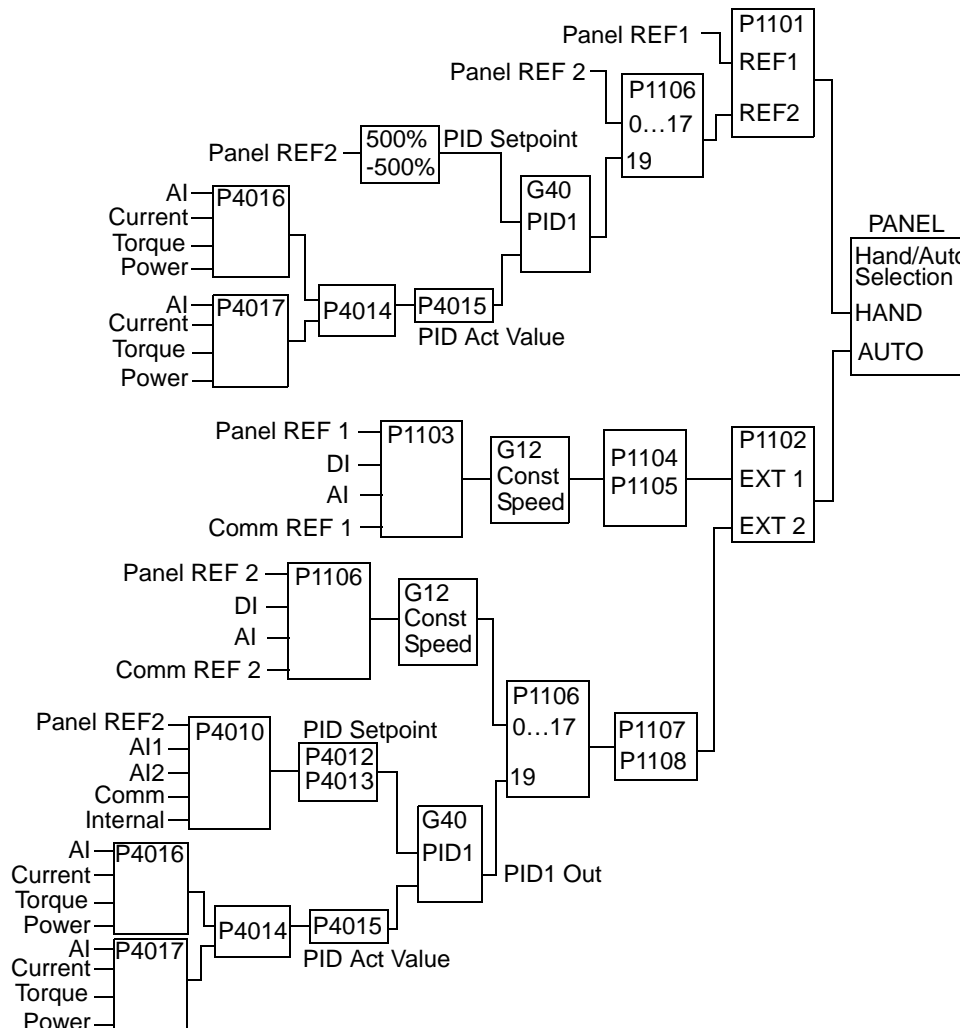

**Note!** In order to activate and use the PID controller Parameter 1106 must be set to value 19.



*PID Controller – Advanced*

ACS550 has 2 separate PID Controllers:

- Process PID (PID1) and
- External PID (PID2)

Process PID (PID1) has 2 separate sets of parameters:

- Process PID (PID1) SET1, defined in Group 40 and
- Process PID (PID1) SET2, defined in Group 41

You can select between the 2 different sets by using parameter 4027.

Typically two different PID-Controller sets are used when the load of the motor changes considerably from one situation to another.

You can use External PID (PID2), defined in Group 42, in 2 different ways:

- Instead of using additional PID-controller hardware, you can set outputs of the ACS550 to control a field instrument like a damper or a valve. In this case, set Parameter 4230 to value 0. (0 is the default value.)
- You can use External PID (PID2) as an additional PID-controller to Process PID (PID1) to trim or fine-tune the speed of the ACS550.

Code	Description
4001	<p><b>GAIN</b></p> <p>Defines the PID Controller's gain.</p> <ul style="list-style-type: none"> <li>• The setting range is 0.1... 100.</li> <li>• At 0.1, the PID Controller output changes one-tenth as much as the error value.</li> <li>• At 100, the PID Controller output changes one hundred times as much as the error value.</li> </ul> <p>Use the proportional gain and integration time values to adjust the responsiveness of the system.</p> <ul style="list-style-type: none"> <li>• A low value for proportional gain and a high value for integral time ensures stable operation, but provides sluggish response.</li> </ul> <p>If the proportional gain value is too large or the integral time too short, the system can become unstable.</p> <p>Procedure:</p> <ul style="list-style-type: none"> <li>• Initially, set: <ul style="list-style-type: none"> <li>• 4001 GAIN = 0.1.</li> <li>• 4002 INTEGRATION TIME = 20 seconds.</li> </ul> </li> <li>• Start the system and see if it reaches the set point quickly while maintaining stable operation. If not, increase GAIN (4001) until the actual signal (or drive speed) oscillates constantly. It may be necessary to start and stop the drive to induce this oscillation.</li> <li>• Reduce GAIN (4001) until the oscillation stops.</li> <li>• Set GAIN (4001) to 0.4 to 0.6 times the above value.</li> <li>• Decrease the INTEGRATION TIME (4002) until the feedback signal (or drive speed) oscillates constantly. It may be necessary to start and stop the drive to induce this oscillation.</li> <li>• Increase INTEGRATION TIME (4002) until the oscillation stops.</li> <li>• Set INTEGRATION TIME (4002) to 1.15 to 1.5 times the above value.</li> <li>• If the feedback signal contains high frequency noise, increase the value of Parameter 1303 FILTER AI1 or 1306 FILTER AI2 until the noise is filtered from the signal.</li> </ul>

Code	Description															
4002	<p><b>INTEGRATION TIME</b></p> <p>Defines the PID Controller's integration time.</p> <p>Integration time is, by definition, is the time required to increase the output by the error value:</p> <ul style="list-style-type: none"> <li>• Error value is constant and 100%.</li> <li>• Gain = 1.</li> <li>• Integration time of 1 second denotes that a 100% change is achieved in 1 second.</li> </ul> <p>0.0 = NOT SEL – Disables integration (I-part of controller).                      0.1...3600.0 = Integration time (seconds).                      See 4001 for adjustment procedure.</p>															
	<p>A = Error                      B = Error value step                      C = Controller output with Gain = 1                      D = Controller output with Gain = 10</p>															
4003	<p><b>DERIVATION TIME</b></p> <p>Defines the PID Controller's derivation time.</p> <ul style="list-style-type: none"> <li>• You can add the derivative of the error to the PID controller output. The derivative is the error value's rate of change. For example, if the process error value changes linearly, the derivative is a constant added to the PID controller output.</li> <li>• The error-derivative is filtered with a 1-pole filter. The time constant of the filter is defined by parameter 4004 PID DERIV FILTER.</li> </ul> <p>0.0 = NOT SEL – Disables the error-derivative part of the PID controller output                      0.1...10.0 = Derivation time (seconds)</p>															
	<p>Process Error Value</p> <p>PID output</p> <p>Gain P 401</p> <p>D-part of controller output</p> <p>P 4003</p>															
4004	<p><b>PID DERIV FILTER</b></p> <p>Defines the filter time constant for the error-derivative part of the PID controller output.</p> <ul style="list-style-type: none"> <li>• Before being added to the PID controller output, the error-derivative is filtered with a 1-pole filter.</li> <li>• Increasing the filter time smooths the error-derivative, reducing noise.</li> </ul> <p>0.0 = NOT SEL – Disables the error-derivative filter.                      0.1...10.0 = Filter time constant (seconds).</p>															
4005	<p><b>ERROR VALUE INV</b></p> <p>Selects either a normal or inverted relationship between the feedback signal and the drive speed.</p> <p>0 = NO – Normal, a decrease in feedback signal increases drive speed. Error = Ref - Fbk                      1 = YES – Inverted, a decrease in feedback signal decreases drive speed. Error = Fbk - Ref</p>															
4006	<p><b>UNITS</b></p> <p>Selects the unit for the PID controller actual values. (PID1 parameters 0128, 0130, and 0132).</p> <ul style="list-style-type: none"> <li>• See parameter 3405 for list of available units.</li> </ul>															
4007	<p><b>UNIT SCALE</b></p> <p>Defines the decimal point location in PID controller actual values.</p> <ul style="list-style-type: none"> <li>• Enter the decimal point location counting in from the right of the entry.</li> <li>• See table for example using pi (3.14159).</li> </ul> <table border="1"> <thead> <tr> <th>4007 Value</th> <th>Entry</th> <th>Display</th> </tr> </thead> <tbody> <tr> <td>0</td> <td>0003</td> <td>3</td> </tr> <tr> <td>1</td> <td>0031</td> <td>3.1</td> </tr> <tr> <td>2</td> <td>0314</td> <td>3.14</td> </tr> <tr> <td>3</td> <td>3142</td> <td>3.142</td> </tr> </tbody> </table>	4007 Value	Entry	Display	0	0003	3	1	0031	3.1	2	0314	3.14	3	3142	3.142
4007 Value	Entry	Display														
0	0003	3														
1	0031	3.1														
2	0314	3.14														
3	3142	3.142														

Code	Description	
4008	<p><b>0 % VALUE</b></p> <p>Defines (together with the next parameter) the scaling applied to the PID controller's actual values (PID1 parameters 0128, 0130, and 0132).</p> <ul style="list-style-type: none"> <li>Units and scale are defined by parameters 4006 and 4007.</li> </ul>	
4009	<p><b>100 % VALUE</b></p> <p>Defines (together with the previous parameter) the scaling applied to the PID controller's actual values.</p> <ul style="list-style-type: none"> <li>Units and scale are defined by parameters 4006 and 4007.</li> </ul>	
4010	<p><b>SET POINT SEL</b></p> <p>Defines the reference signal source for the PID controller.</p> <ul style="list-style-type: none"> <li>Parameter has no significance when the PID regulator is by-passed (see 8121 REG BYPASS CTRL).</li> </ul> <p>0 = keypad – Control panel provides reference.            1 = AI1 – Analog input 1 provides reference.            2 = AI2 – Analog input 2 provides reference.            8 = comm – Fieldbus provides reference.            9 = COMM + AI1 – Defines a fieldbus and analog input 1 (AI1) combination as the reference source. See Analog Input Reference Correction below.            10 = COMM * AI1 – Defines a fieldbus and analog input 1 (AI1) combination as the reference source. See Analog Input Reference Correction below.            11 = DI3U, 4D(RNC) – Digital inputs, acting as a motor potentiometer control, provide reference.</p> <ul style="list-style-type: none"> <li>DI3 increases the speed (the U stands for “up”)</li> <li>DI4 decreases the reference (the D stands for “down”).</li> <li>Parameter 2205 ACCELER TIME 2 controls the reference signal's rate of change.</li> <li>R = Stop command resets the reference to zero.</li> <li>NC = Reference value is not copied.</li> </ul> <p>12 = DI3U, 4D(NC) – Same as DI3U, 4D(RNC) above, except:</p> <ul style="list-style-type: none"> <li>Stop command does not reset reference to zero. At restart the motor ramps up, at the selected acceleration rate, to the stored reference.</li> </ul> <p>13 = DI5U, 6D(NC) – Same as DI3U, 4D(NC) above, except:</p> <ul style="list-style-type: none"> <li>Uses digital inputs DI5 and DI6.</li> </ul> <p>14 = AI1 + AI2 – Defines an analog input 1 (AI1) and analog input 2 (AI2) combination as the reference source. See Analog Input Reference Correction below.            15 = AI1 * AI2 – Defines an analog input 1 (AI1) and analog input 2 (AI2) combination as the reference source. See Analog Input Reference Correction below.            16 = AI1 - AI2 – Defines an analog input 1 (AI1) and analog input 2 (AI2) combination as the reference source. See Analog Input Reference Correction below.            17 = AI1/AI2 – Defines an analog input 1 (AI1) and analog input 2 (AI2) combination as the reference source. See Analog Input Reference Correction below.            19 = INTERNAL – A constant value set using parameter 4011 provides reference.</p>	

Code	Description										
	<p><b>Analog Input Reference Correction</b> Parameter values 9, 10, and 14...17 use the formula in the following table.</p> <table border="1"> <thead> <tr> <th>Value Setting</th> <th>AI reference is calculated as following:</th> </tr> </thead> <tbody> <tr> <td>C + B</td> <td>C value + (B value - 50% of reference value)</td> </tr> <tr> <td>C * B</td> <td>C value * (B value / 50% of reference value)</td> </tr> <tr> <td>C - B</td> <td>(C value + 50% of reference value) - B value</td> </tr> <tr> <td>C / B</td> <td>(C value * 50% of reference value) / B value</td> </tr> </tbody> </table> <p>Where:</p> <ul style="list-style-type: none"> <li>C = Main Reference value (= COMM for values 9, 10 and = AI1 for values 14...17).</li> <li>B = Correcting reference (= AI1 for values 9, 10 and = AI2 for values 14...17).</li> </ul> <p><b>Example:</b> The figure shows the reference source curves for value settings 9, 10, and 14...17, where:</p> <ul style="list-style-type: none"> <li>C = 25%.</li> <li>P 4012 SETPOINT MIN = 0.</li> <li>P 4013 SETPOINT MAX = 0.</li> <li>B varies along the horizontal axis.</li> </ul>	Value Setting	AI reference is calculated as following:	C + B	C value + (B value - 50% of reference value)	C * B	C value * (B value / 50% of reference value)	C - B	(C value + 50% of reference value) - B value	C / B	(C value * 50% of reference value) / B value
Value Setting	AI reference is calculated as following:										
C + B	C value + (B value - 50% of reference value)										
C * B	C value * (B value / 50% of reference value)										
C - B	(C value + 50% of reference value) - B value										
C / B	(C value * 50% of reference value) / B value										
4011	<p><b>INTERNAL SETPNT</b> Sets a constant value used for the process reference. • Units and scale are defined by parameters 4006 and 4007.</p>										
4012	<p><b>SETPOINT MIN</b> Sets the minimum value for the reference signal source. See parameter 4010.</p>										
4013	<p><b>SETPOINT MAX</b> Sets the maximum value for the reference signal source. See parameter 4010.</p>										
4014	<p><b>FBK SEL</b> Defines the PID controller feedback (actual signal).</p> <ul style="list-style-type: none"> <li>You can define a combination of two actual values (ACT1 and ACT2) as the feedback signal.</li> <li>Use parameter 4016 to define the source for actual value 1 (ACT1).</li> <li>Use parameter 4017 to define the source for actual value 2 (ACT2).</li> </ul> <p>1 = ACT1 – Actual value 1 (ACT1) provides the feedback signal.                  2 = ACT1-ACT2 – ACT1 minus ACT2 provides the feedback signal.                  3 = ACT1+ACT2 – ACT1 plus ACT2 provides the feedback signal.                  4 = ACT1*ACT2 – ACT1 times ACT2 provides the feedback signal.                  5 = ACT1/ACT2 – ACT1 divided by ACT2 provides the feedback signal.                  6 = MIN (A1, A2) – The smaller of ACT1 or ACT2 provides the feedback signal.                  7 = MAX (A1, A2) – The greater of ACT1 or ACT2 provides the feedback signal.                  8 = SQRT (A1-A2) – Square root of the value for ACT1 minus ACT2 provides the feedback signal.                  9 = SQA1 + SQA2 – Square root of ACT1 plus the square root of ACT2 provides the feedback signal.                  10 = SQRT (ACT1) – Square root of ACT1 provides the feedback signal.</p>										
4015	<p><b>FBK MULTIPLIER</b> Defines an extra multiplier for the PID FBK value defined by parameter 4014.</p> <ul style="list-style-type: none"> <li>Used mainly in applications where the flow is calculated from the pressure difference.</li> </ul> <p>0 = NOT USED.                  -32.768...32.767 = Multiplier applied to the signal defined by parameter 4014 FBK SEL.</p> <p><b>Example:</b> FBK = Multiplier × <math>\sqrt{A1 - A2}</math></p>										

Code	Description	
4016	<p><b>ACT1 INPUT</b>                      Defines the source for actual value 1 (ACT1).                      1 = AI 1 – Uses analog input 1 for ACT1.                      2 = AI 2 – Uses analog input 2 for ACT1.                      3 = Current – Uses current for ACT1, scaled so:                      • Min ACT1 = 0 current                      • Max ACT1 = 2 x nominal current                      4 = Torque – Uses torque for ACT1, scaled so:                      • Min ACT1 = -2 x nominal torque                      • Max ACT1 = 2 x nominal torque                      5 = Power – Uses power for ACT1, scaled so:                      • Min ACT1 = -2 x nominal power                      • Max ACT1 = 2 x nominal power</p>	
4017	<p><b>ACT2 INPUT</b>                      Defines the source for actual value 2 (ACT2).                      1 = AI 1 – Uses analog input 1 for ACT2.                      2 = AI 2 – Uses analog input 2 for ACT2.                      3 = Current – Uses current for ACT2, scaled so:                      • Min ACT2 = 0 current                      • Max ACT2 = 2 x nominal current                      4 = Torque – Uses torque for ACT2, scaled so:                      • Min ACT2 = -2 x nominal torque                      • Max ACT2 = 2 x nominal torque                      5 = Power – Uses power for ACT2, scaled so:                      • Min ACT2 = -2 x nominal power                      • Max ACT2 = 2 x nominal power</p>	
4018	<p><b>ACT1 MINIMUM</b>                      Sets the minimum value for ACT1.                      • Used with analog input min/max settings (e.g. 1301 MINIMUM AI1, 1302 MAXIMUM AI1).                      • Scales analog inputs used as actual values.                      • See figure: A= Normal; B = Inversion (ACT1 MINIMUM &gt; ACT1 MAXIMUM)</p>	
4019	<p><b>ACT1 MAXIMUM</b>                      Sets the maximum value for ACT1.                      • See 4018 ACT1 MINIMUM.</p>	
4020	<p><b>ACT2 MINIMUM</b>                      Sets the minimum value for ACT2.                      • See 4018 ACT1 MINIMUM.</p>	
4021	<p><b>ACT2 MAXIMUM</b>                      Sets the maximum value for ACT2.                      • See 4018 ACT1 MINIMUM.</p>	

Code	Description	
4022	<p><b>SLEEP SELECTION</b></p> <p>Defines the control for the PID sleep function.</p> <p>0 = NOT SEL– Disables the PID sleep control function.</p> <p>1 = DI1 – Defines digital input DI1 as the control for the PID sleep function.</p> <ul style="list-style-type: none"> <li>• Activating the digital input activates the sleep function.</li> <li>• De-activating the digital input restores PID control.</li> </ul> <p>2...6 = DI2...DI6 – Defines digital input DI2...DI6 as the control for the PID sleep function.</p> <ul style="list-style-type: none"> <li>• See DI1 above.</li> </ul> <p>7 = INTERNAL – Defines the output rpm/frequency, process reference, and process actual value as the control for the PID sleep function. Refer to parameters 4025 WAKE-UP DEV and 4023 PID SLEEP LEVEL.</p> <p>-1 = DI1(INV) – Defines an inverted digital input DI1 as the control for the PID sleep function.</p> <ul style="list-style-type: none"> <li>• De-activating the digital input activates the sleep function.</li> <li>• Activating the digital input restores PID control.</li> </ul> <p>-2...-6 = DI2(INV)...DI6(INV) – Defines an inverted digital input DI2...DI6 as the control for the PID sleep function.</p> <ul style="list-style-type: none"> <li>• See DI1(INV) above.</li> </ul>	
4023	<p><b>PID SLEEP LEVEL</b></p> <p>Sets the motor speed / frequency that enables the PID sleep function – a motor speed / frequency below this level, for at least the time period 4024 PID SLEEP DELAY enables the PID sleep function (stopping the drive).</p> <ul style="list-style-type: none"> <li>• Requires 4022 = 7 INTERNAL.</li> <li>• See figure: A = PID output level; B = PID process feedback.</li> </ul>	
4024	<p><b>PID SLEEP DELAY</b></p> <p>Sets the time delay for the PID sleep function – a motor speed / frequency below 4023 PID SLEEP LEVEL for at least this time period enables the PID sleep function (stopping the drive).</p> <ul style="list-style-type: none"> <li>• See 4023 PID SLEEP LEVEL above.</li> </ul>	
4025	<p><b>WAKE-UP DEVIATION</b></p> <p>Defines the wake-up deviation – a deviation from the setpoint greater than this value, for at least the time period 4026 WAKE-UP DELAY, re-starts the PID controller.</p> <ul style="list-style-type: none"> <li>• Parameters 4006 and 4007 define the units and scale.</li> <li>• Parameter 4005 = 0, Wake-up level = Setpoint - Wake-up deviation.</li> <li>• Parameter 4005 = 1, Wake-up level = Setpoint + Wake-up deviation.</li> <li>• Wake-up level can be above or below setpoint.</li> </ul> <p>See figures:</p> <ul style="list-style-type: none"> <li>• C = Wake-up level when parameter 4005 = 1</li> <li>• D = Wake-up level when parameter 4005 = 0</li> <li>• E = Feedback is above wake-up level and lasts longer than 4026 WAKE-UP DELAY – PID function wakes up.</li> <li>• F = Feedback is below wake-up level and lasts longer than 4026 WAKE-UP DELAY – PID function wakes up.</li> </ul>	
4026	<p><b>WAKE-UP DELAY</b></p> <p>Defines the wake-up delay – a deviation from the setpoint greater than 4025 WAKE-UP DEVIATION, for at least this time period, re-starts the PID controller.</p>	

Code	Description
4027	<p><b>PID 1 PARAM SET</b></p> <p>Defines how selections are made between PID Set 1 and PID Set 2.</p> <p>PID parameter set selection. When set 1 is selected, parameters 4001...4026 are used.</p> <p>When set 2 is selected, parameters 4101...4126 are used.</p> <p>0 = SET 1 – PID Set 1 (parameters 4001...4026) is active.</p> <p>1 = DI1 – Defines digital input DI1 as the control for PID Set selection.</p> <ul style="list-style-type: none"> <li>• Activating the digital input selects PID Set 2.</li> <li>• De-activating the digital input selects PID Set 1.</li> </ul> <p>2...6 = DI2...DI6 – Defines digital input DI2...DI6 as the control for PID Set selection.</p> <ul style="list-style-type: none"> <li>• See DI1 above.</li> </ul> <p>7 = SET 2 – PID Set 2 (parameters 4101...4126) is active.</p> <p>8...11 = TIMER FUNCTION 1...4 – Defines the Timer function as the control for the PID Set selection (Timer function de-activated = PID Set 1; Timer function activated = PID Set 2)</p> <ul style="list-style-type: none"> <li>• See parameter Group 36: Timer Functions.</li> </ul> <p>-1 = DI1(INV) – Defines an inverted digital input DI1 as the control for PID Set selection.</p> <ul style="list-style-type: none"> <li>• Activating the digital input selects PID Set 1.</li> <li>• De-activating the digital input selects PID Set 2.</li> </ul> <p>-2...-6 = DI2(INV)...DI6(INV) – Defines an inverted digital input DI2...DI6 as the control for PID Set selection.</p> <ul style="list-style-type: none"> <li>• See DI1(INV) above.</li> </ul>

**Group 41: Process PID Set 2**

Parameters of this group belong to PID parameter set 2. The operation of parameters 4101...4126 is analogous with set 1 parameters 4001...4026.

PID parameter set 2 can be selected by parameter 4027 PID 1 PARAM SET.

Group 41: Process PID Set 2	
Code	Description
4101	See 4001 ...4026
...	
4126	



## Group 42: External / Trimming PID

This group defines the parameters used for the second PID controller (PID2), which is used for the External / Trimming PID.

The operation of parameters 4201...4221 is analogous with Process PID set 1 (PID1) parameters 4001...4021.

Code	Description
4201 ... 4221	See 4001 ...4021
4228	<p><b>ACTIVATE</b></p> <p>Defines the source for enabling the external PID function.</p> <ul style="list-style-type: none"> <li>Requires 4230 TRIM MODE = 0 NOT SEL.</li> </ul> <p>0 = NOT SEL – Disables external PID control.</p> <p>1 = DI1 – Defines digital input DI1 as the control for enabling external PID control.</p> <ul style="list-style-type: none"> <li>Activating the digital input enables external PID control.</li> <li>De-activating the digital input disables external PID control.</li> </ul> <p>2...6 = DI2...DI6 – Defines digital input DI2...DI6 as the control for enabling external PID control.</p> <ul style="list-style-type: none"> <li>See DI1 above.</li> </ul> <p>7 = DRIVE RUN – Defines the start command as the control for enabling external PID control.</p> <ul style="list-style-type: none"> <li>Activating the start command (drive is running) enables external PID control.</li> </ul> <p>8 = ON – Defines the power-on as the control for enabling external PID control.</p> <ul style="list-style-type: none"> <li>Activating power to the drive enables external PID control.</li> </ul> <p>9...12 = TIMER FUNCTION 1...4 – Defines the Timer function as the control for enabling external PID control (Timer function active enables external PID control).</p> <ul style="list-style-type: none"> <li>See parameter Group 36: Timer Functions.</li> </ul> <p>-1 = DI1(INV) – Defines an inverted digital input DI1 as the control for enabling external PID control.</p> <ul style="list-style-type: none"> <li>Activating the digital input disables external PID control.</li> <li>De-activating the digital input enables external PID control.</li> </ul> <p>-2...-6 = DI2(INV)...DI6(INV) – Defines an inverted digital input DI2...DI6 as the control for enabling external PID control.</p> <ul style="list-style-type: none"> <li>See DI1(INV) above.</li> </ul>
4229	<p><b>OFFSET</b></p> <p>Defines the offset for the PID output.</p> <ul style="list-style-type: none"> <li>When PID is activated, output starts from this value.</li> <li>When PID is deactivated, output resets to this value.</li> <li>Parameter is active when 4230 TRIM MODE = 0 (trim mode is not active).</li> </ul>
4230	<p><b>TRIM MODE</b></p> <p>Selects the type of trim, if any. Using the trim it is possible to combine a corrective factor to the drive reference.</p> <p>0 = NOT SEL – Disables the trim function.</p> <p>1 = PROPORTIONAL – Adds a trim factor that is proportional to the rpm/Hz reference.</p> <p>2 = DIRECT – Adds a trim factor based on the control loop's maximum limit.</p>
4231	<p><b>TRIM SCALE</b></p> <p>Defines the multiplier (as a percent, plus or minus) used in the trim mode.</p>

Code	Description
4232	<p><b>CORRECTION SRC</b></p> <p>Defines the trimming reference for the correction source.</p> <p>1 = PID2 REF – Uses appropriate REF MAX (SWITCH A OR B):</p> <ul style="list-style-type: none"> <li>• 1105 REF 1 MAX when REF1 is active (A).</li> <li>• 1108 REF 2 MAX when REF2 is active (B).</li> </ul> <p>2 = PID2 OUTPUT – Uses the absolute maximum speed or frequency (Switch C):</p> <ul style="list-style-type: none"> <li>• 2002 MAXIMUM SPEED if 9904 MOTOR CONTROL MODE = 1 SPEED or 2 TORQUE.</li> <li>• 2008 MAXIMUM FREQUENCY IF 9904 MOTOR CONTROL MODE = 3 SCALAR.</li> </ul>

**Group 50: Encoder**

This group defines the setup for encoder use:

- Set the number of encoder pulses per shaft revolution.
- Enable the encoder operation.
- Defines how mechanical angle and revolution data is reset.

Group 50: Encoder	
Code	Description RangeResolutionDefaultS
5001	<p><b>PULSE NR</b></p> <p>Sets the number of pulses provided by an optional encoder for each full motor shaft revolution.</p>
5002	<p><b>ENCODER ENABLE</b></p> <p>Enables/disables optional external encoder.</p> <p>0 = DISABLE – Drive uses speed feedback derived from the internal motor model (applies for any setting of parameter 9904 MOTOR CTRL MODE).</p> <p>1 = ENABLE – Drive uses feedback from an optional encoder. This function requires the Pulse Encoder Interface Module (OTAC-01) and an encoder. Operation depends on the setting of parameter 9904 MOTOR CTRL MODE:</p> <ul style="list-style-type: none"> <li>• 9904 = 1 (VECTOR: SPEED), the encoder provides improved speed feedback and improved low speed torque accuracy.</li> <li>• 9904 = 2 (VECTOR: TORQ), the encoder provides improved speed feedback and improved low speed torque accuracy.</li> <li>• 9904 = 3 (SCALAR: SPEED), the encoder provides speed feedback. (This is not closed loop speed regulation. However, using parameter 2608 SLIP COMP RATIO and an encoder improves steady state speed accuracy.)</li> </ul>
5003	<p><b>ENCODER FAULT</b></p> <p>Defines the drive response if the encoder signal is lost.</p> <p>1 = FAULT – A fault is generated, and the motor coasts to a stop.</p> <p>2 = WARNING – An alarm is generated and the ACS550 operates as is if parameter 5002 ENCODER ENABLE = 0 (DISABLE), that is, speed feedback is derived from the internal motor model.</p>
5010	<p><b>Z PLS ENABLE</b></p> <p>Enables/disables the use of an encoder's Z-pulse to define the motor shaft's zero position. When enabled, a Z-pulse input resets parameter 0146 MECH ANGLE to zero to define the shaft's zero position. This function requires an encoder that provides Z-pulse signals.</p> <p>0 = DISABLE – Z-pulse input is not present or ignored if present.</p> <p>1 = ENABLE – A Z-pulse input resets parameter 0146 MECH ANGLE to zero.</p>
5011	<p><b>POSITION RESET</b></p> <p>Resets the encoder's position feedback. This parameter is self-clearing.</p> <p>0 = DISABLE – Inactive.</p> <p>1 = ENABLE – Resets the encoder position feedback. Parameters reset depends on the state of parameter 5010 Z PLS ENABLE:</p> <ul style="list-style-type: none"> <li>• 5010 = ENABLE – Reset applies only to parameter 0147 MECH REVS.</li> <li>• 5010 = DISABLE – Reset applies to parameters 0147 MECH REVS and 0146 MECH ANGLE.</li> </ul>

### Group 51: Ext Comm Module

This group defines set-up variables for a fieldbus adapter (FBA) communication module. For more information on these parameters, refer to the user's manual supplied with the FBA module.

Code	Description
5101	<p><b>FBA TYPE</b></p> <p>Displays the type of the connected fieldbus adapter module.</p> <p>0 = NOT DEFINED – Module not found, or not properly connected, or parameter 9802 is not set to 4 (EXT FBA).</p> <p>1 = PROFIBUS-DP –</p> <p>16 = INTERBUS –</p> <p>21 = LONWORKS –</p> <p>32 = CANOPEN –</p> <p>37 = DEVICENET –</p> <p>64 = MODBUS PLUS –</p> <p>101 = CONTROLNET –</p>
5102 ... 5126	<p><b>FB PAR 2...FB PAR 26</b></p> <p>Refer to communication module documentation for more information on these parameters.</p>
5127	<p><b>FBA PAR REFRESH</b></p> <p>Validates any changed fieldbus parameter settings.</p> <ul style="list-style-type: none"> <li>• After refreshing, the value reverts automatically to DONE.</li> </ul>
5128	<p><b>FILE CPI FW REV</b></p> <p>Displays the CPI firmware revision of the drive's fieldbus adapter configuration file. Format is xyz where:</p> <ul style="list-style-type: none"> <li>• x = major revision number</li> <li>• y = minor revision number</li> <li>• z = correction number</li> </ul> <p><b>Example:</b> 107 = revision 1.07</p>
5129	<p><b>FILE CONFIG ID</b></p> <p>Displays the revision of the drive's fieldbus adapter module's configuration file identification.</p> <ul style="list-style-type: none"> <li>• File configuration information is drive application program-dependent.</li> </ul>
5130	<p><b>FILE CONFIG REV</b></p> <p>Contains the revision of the drive's fieldbus adapter module configuration file.</p> <p><b>Example:</b> 1 = revision 1</p>
5131	<p><b>FBA STATUS</b></p> <p>Contains the status of the adapter module.</p> <p>0 = IDLE – Adapter not configured.</p> <p>1 = EXEC. INIT – Adapter is initializing.</p> <p>2 = TIME OUT – A timeout has occurred in the communication between the adapter and the drive.</p> <p>3 = CONFIG ERROR – Adapter configuration error.</p> <ul style="list-style-type: none"> <li>• The revision code of the adapter's CPI firmware revision is older than required CPI firmware version defined in the drive's configuration file (parameter 5132 &lt; 5128).</li> </ul> <p>4 = OFF-LINE – Adapter is off-line.</p> <p>5 = ON-LINE – Adapter is on-line.</p> <p>6 = RESET – Adapter is performing a hardware reset.</p>
5132	<p><b>FBA CPI FW REV</b></p> <p>Contains the revision of the module's CPI program. Format is xyz where:</p> <ul style="list-style-type: none"> <li>• x = major revision number</li> <li>• y = minor revision number</li> <li>• z = correction number</li> </ul> <p><b>Example:</b> 107 = revision 1.07</p>
5133	<p><b>FBA APPL FW REV</b></p> <p>Contains the revision of the module's application program Format is xyz (see parameter 5132).</p>

## Group 52: Panel Communication

This group defines the communication settings for the control panel port on the drive. Normally, when using the supplied control panel, there is no need to change settings in this group.

In this group, parameter modifications take effect on the next power-up.

Code	Description
5201	<b>STATION ID</b> Defines the address of the drive. <ul style="list-style-type: none"> <li>• Two units with the same address are not allowed on-line.</li> <li>• Range: 1...247</li> </ul>
5202	<b>BAUDRATE</b> Defines the communication speed of the drive in kbits per second (kbits/s). 9.6 19.2 38.4 57.6 115.2
5203	<b>PARITY</b> Sets the character format to be used with the panel communication. 0 = 8N1 – No parity, one stop bit. 1 = 8N2 – No parity, two stop bits. 2 = 8E1 – Even parity, one stop bit. 3 = 8O1 – Odd parity, one stop bit.
5204	<b>OK MESSAGES</b> Contains a count of valid Modbus messages received by the drive. <ul style="list-style-type: none"> <li>• During normal operation, this counter is increasing constantly.</li> </ul>
5205	<b>PARITY ERRORS</b> Contains a count of the characters with a parity error that is received from the bus. For high counts, check: <ul style="list-style-type: none"> <li>• Parity settings of devices connected on the bus – they must not differ.</li> <li>• Ambient electro-magnetic noise levels – high noise levels generate errors.</li> </ul>
5206	<b>FRAME ERRORS</b> Contains a count of the characters with a framing error that the bus receives. For high counts, check: <ul style="list-style-type: none"> <li>• Communication speed settings of devices connected on the bus – they must not differ.</li> <li>• Ambient electro-magnetic noise levels – high noise levels generate errors.</li> </ul>
5207	<b>BUFFER OVERRUNS</b> Contains a count of the characters received that cannot be placed in the buffer. <ul style="list-style-type: none"> <li>• Longest possible message length for the drive is 128 bytes.</li> <li>• Received messages exceeding 128 bytes overflow the buffer. The excess characters are counted.</li> </ul>
5208	<b>CRC ERRORS</b> Contains a count of the messages with a CRC error that the drive receives. For high counts, check: <ul style="list-style-type: none"> <li>• Ambient electro-magnetic noise levels – high noise levels generate errors.</li> <li>• CRC calculations for possible errors.</li> </ul>

### Group 53: EFB Protocol

This group defines set-up variables used for an embedded fieldbus (EFB) communication protocol. The standard EFB protocol in the ACS550 is Modbus. See "Embedded Fieldbus" starting on page 149.

Code	Description
5301	<b>EFB PROTOCOL ID</b> Contains the identification and program revision of the protocol. <ul style="list-style-type: none"> <li>• Format: XXYY, where xx = protocol ID, and YY = program revision.</li> </ul>
5302	<b>EFB STATION ID</b> Defines the node address of the RS485 link. <ul style="list-style-type: none"> <li>• The node address on each unit must be unique.</li> </ul>
5303	<b>EFB BAUD RATE</b> Defines the communication speed of the RS485 link in kbits per second (kbits/s). 1.2 kbits/s 2.4 kbits/s 4.8 kbits/s 9.6 kbits/s 19.2 kbits/s 38.4 kbits/s 57.6 kbits/s 76.8 kbits/s
5304	<b>EFB PARITY</b> Defines the data length, parity and stop bits to be used with the RS485 link communication. <ul style="list-style-type: none"> <li>• The same settings must be used in all on-line stations.</li> </ul> 0 = 8N1 – 8 data bits, No parity, one stop bit. 1 = 8N2 – 8 data bits, No parity, two stop bits. 2 = 8E1 – 8 data bits, Even parity, one stop bit. 3 = 8O1 – 8 data bits, Odd parity, one stop bit.
5305	<b>EFB CTRL PROFILE</b> Selects the communication profile used by the EFB protocol. 0 = ABB DRV LIM – Operation of Control/Status Words conforms to ABB Drives Profile, as used in ACS400. 1 = DCU PROFILE – Operation of Control/Status Words conforms to 32-bit DCU Profile. 2 = ABB DRV FULL – Operation of Control/Status Words conforms to ABB Drives Profile, as used in ACS600/800.
5306	<b>EFB OK MESSAGES</b> Contains a count of valid messages received by the drive. <ul style="list-style-type: none"> <li>• During normal operation, this counter is increasing constantly.</li> </ul>
5307	<b>EFB CRC ERRORS</b> Contains a count of the messages with a CRC error received by the drive. For high counts, check: <ul style="list-style-type: none"> <li>• Ambient electro-magnetic noise levels – high noise levels generate errors.</li> <li>• CRC calculations for possible errors.</li> </ul>
5308	<b>EFB UART ERRORS</b> Contains a count of the messages with a character error received by the drive.
5309	<b>EFB STATUS</b> Contains the status of the EFB protocol. 0 = IDLE – EFB protocol is configured, but not receiving any messages. 1 = EXEC. INIT – EFB protocol is initializing. 2 = TIME OUT – A timeout has occurred in the communication between the network master and the EFB protocol. 3 = CONFIG ERROR – EFB protocol has a configuration error. 4 = OFF-LINE – EFB protocol is receiving messages that are NOT addressed to this drive. 5 = ON-LINE – EFB protocol is receiving messages that are addressed to this drive. 6 = RESET – EFB protocol is performing a hardware reset. 7 = LISTEN ONLY – EFB protocol is in listen-only mode.
5310	<b>EFB PAR 10</b> Specifies the parameter mapped to Modbus Register 40005.

<b>Code</b>	<b>Description</b>
5311	<b>EFB PAR 11</b> Specifies the parameter mapped to Modbus Register 40006.
5312	<b>EFB PAR 12</b> Specifies the parameter mapped to Modbus Register 40007.
5313	<b>EFB PAR 13</b> Specifies the parameter mapped to Modbus Register 40008.
5314	<b>EFB PAR 14</b> Specifies the parameter mapped to Modbus Register 40009.
5315	<b>EFB PAR 15</b> Specifies the parameter mapped to Modbus Register 40010.
5316	<b>EFB PAR 16</b> Specifies the parameter mapped to Modbus Register 40011.
5317	<b>EFB PAR 17</b> Specifies the parameter mapped to Modbus Register 40012.
5318	<b>EFB PAR 18</b> Reserved.
5319	<b>EFB PAR 19</b> ABB Drives profile (ABB DRV LIM or ABB DRV FULL) Control Word. Read only copy of the Fieldbus Control Word.
5320	<b>EFB PAR 20</b> ABB Drives profile (ABB DRV LIM or ABB DRV FULL) Status Word. Read only copy of the Fieldbus Status Word.

## Group 81: PFC Control

This group defines a Pump-Fan Control (PFC) mode of operation. The major features of PFC control are:

- The ACS550 controls the motor of pump no. 1, varying the motor speed to control the pump capacity. This motor is the speed regulated motor.
- Direct line connections power the motor of pump no. 2 and pump no.3, etc. The ACS550 switches pump no. 2 (and then pump no. 3, etc.) on and off as needed. These motors are auxiliary motors.
- The ACS550 PID control uses two signals: a process reference and an actual value feedback. The PID controller adjusts the speed (frequency) of the first pump such that the actual value follows the process reference.
- When demand (defined by the process reference) exceeds the first motor's capacity (user defined as a frequency limit), the PFC control automatically starts an auxiliary pump. The PFC also reduces the speed of the first pump to account for the auxiliary pump's addition to total output. Then, as before, the PID controller adjusts the speed (frequency) of the first pump such that the actual value follows the process reference. If demand continues to increase, PFC adds additional auxiliary pumps, using the same process.
- When demand drops, such that the first pump speed falls below a minimum limit (user defined by a frequency limit), the PFC control automatically stops an auxiliary pump. The PFC also increases the speed of the first pump to account for the auxiliary pump's missing output.
- An Interlock function (when enabled) identifies off-line (out of service) motors, and the PFC control skips to the next available motor in the sequence.
- An Autochange function (when enabled and with the appropriate switchgear) equalizes duty time between the pump motors. Autochange periodically increments the position of each motor in the rotation – the speed regulated motor becomes the last auxiliary motor, the first auxiliary motor becomes the speed regulated motor, etc.

Code	Description
8103	<p><b>REFERENCE STEP 1</b></p> <p>Sets a percentage value that is added to the process reference.</p> <ul style="list-style-type: none"> <li>• Applies only when <u>at least one</u> auxiliary (constant speed) motor is running.</li> <li>• Default value is 0%.</li> </ul> <p><b>Example:</b> An ACS550 operates three parallel pumps that maintain water pressure in a pipe.</p> <ul style="list-style-type: none"> <li>• 4011 INTERNAL SETPNT sets a constant pressure reference that controls the pressure in the pipe.</li> <li>• The speed regulated pump operates alone at low water consumption levels.</li> <li>• As water consumption increases, first one constant speed pump operates, then, the second.</li> <li>• As flow increases, the pressure at the output end of the pipe drops relative to the pressure measured at the input end. As auxiliary motors step in to increase the flow, the adjustments below correct the reference to more closely match the output pressure.</li> <li>• When the first auxiliary pump operates, increase the reference with parameter 8103 REFERENCE STEP 1.</li> <li>• When both auxiliary pumps operate, increase the reference with parameter 8103 reference step 1 + parameter 8104 reference step 2.</li> <li>• When three auxiliary pumps operate, increase the reference with parameter 8103 REFERENCE STEP 1 + parameter 8104 REFERENCE STEP 2 + parameter 8105 REFERENCE STEP 3.</li> </ul>



Code	Description
8104	<p><b>REFERENCE STEP 2</b></p> <p>Sets a percentage value that is added to the process reference.</p> <ul style="list-style-type: none"> <li>• Applies only when <u>at least two</u> auxiliary (constant speed) motors are running.</li> <li>• See parameter 8103 REFERENCE STEP1.</li> </ul>
8105	<p><b>REFERENCE STEP 3</b></p> <p>Sets a percentage value that is added to the process reference.</p> <ul style="list-style-type: none"> <li>• Applies only when <u>at least three</u> auxiliary (constant speed) motors are running.</li> <li>• See parameter 8103 REFERENCE STEP1.</li> </ul>
8109	<p><b>START FREQ 1</b></p> <p>Sets the frequency limit used to start the first auxiliary motor. The first auxiliary motor starts if:</p> <ul style="list-style-type: none"> <li>• No auxiliary motors are running.</li> <li>• ACS550 output frequency exceeds the limit: 8109 + 1 Hz.</li> <li>• Output frequency stays above a relaxed limit (8109 - 1 Hz) for at least the time: 8115 AUX MOT START D.</li> </ul> <p>After the first auxiliary motor starts:</p> <ul style="list-style-type: none"> <li>• Output frequency decreases by the value = (8109 START FREQ 1) - (8112 LOW FREQ 1).</li> <li>• In effect, the output of the speed regulated motor drops to compensate for the input from the auxiliary motor.</li> </ul> <p>See figure, where:</p> <ul style="list-style-type: none"> <li>• A = (8109 START FREQ 1) - (8112 LOW FREQ 1)</li> <li>• B = Output frequency increase during the start delay.</li> <li>• C = Diagram showing auxiliary motor's run status as frequency increases (1 = On).</li> </ul> <p><b>Note!</b> 8109 START FREQ 1 value must be between:</p> <ul style="list-style-type: none"> <li>• 8112 LOW FREQ 1</li> <li>• (2008 MAXIMUM FREQ) -1.</li> </ul>
8110	<p><b>START FREQ 2</b></p> <p>Sets the frequency limit used to start the second auxiliary motor.</p> <ul style="list-style-type: none"> <li>• See 8109 START FREQ 1 for a complete description of the operation.</li> </ul> <p>The second auxiliary motor starts if:</p> <ul style="list-style-type: none"> <li>• One auxiliary motor is running.</li> <li>• ACS550 output frequency exceeds the limit: 8110 + 1.</li> <li>• Output frequency stays above the relaxed limit (8110 - 1 Hz) for at least the time: 8115 AUX MOT START D.</li> </ul>
8111	<p><b>START FREQ 3</b></p> <p>Sets the frequency limit used to start the third auxiliary motor.</p> <ul style="list-style-type: none"> <li>• See 8109 START FREQ 1 for a complete description of the operation.</li> </ul> <p>The third auxiliary motor starts if:</p> <ul style="list-style-type: none"> <li>• Two auxiliary motors are running.</li> <li>• ACS550 output frequency exceeds the limit: 8111 + 1 Hz.</li> <li>• Output frequency stays above the relaxed limit (8111 - 1 Hz) for at least the time: 8115 AUX MOT START D.</li> </ul>

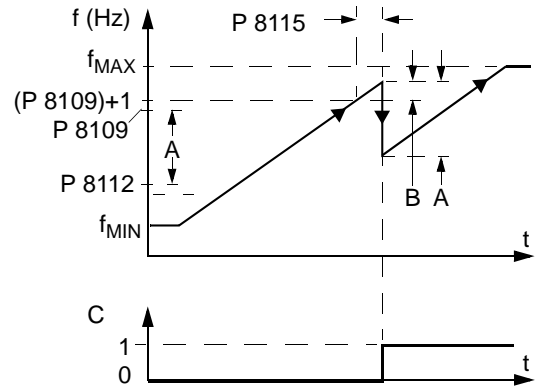

Code	Description
8112	<p><b>LOW FREQ 1</b></p> <p>Sets the frequency limit used to stop the first auxiliary motor. The first auxiliary motor stops if:</p> <ul style="list-style-type: none"> <li>The first auxiliary motor is running alone.</li> <li>ACS550 output frequency drops below the limit: 8112 - 1.</li> <li>Output frequency stays below the relaxed limit (8112 + 1 Hz) for at least the time: 8116 AUX MOT STOP D.</li> </ul> <p>After the first auxiliary motor stops:</p> <ul style="list-style-type: none"> <li>Output frequency increases by the value = (8109 START FREQ 1) - (8112 LOW FREQ 1).</li> <li>In effect, the output of the speed regulated motor increases to compensate for the loss of the auxiliary motor.</li> </ul> <p>See figure, where:</p> <ul style="list-style-type: none"> <li>A = (8109 START FREQ 1) - (8112 LOW FREQ 1)</li> <li>B = Output frequency decrease during the stop delay.</li> <li>C = Diagram showing auxiliary motor's run status as frequency decreases (1 = On).</li> <li>Grey path = Shows hysteresis – if time is reversed, the path backwards is not the same. For details on the path for starting, see the diagram at 8109 START FREQ 1.</li> </ul> <p><b>Note!</b> Low Frequency 1 value must be between:</p> <ul style="list-style-type: none"> <li>(2007 MINIMUM FREQ) +1.</li> <li>8109 START FREQ 1</li> </ul>
8113	<p><b>LOW FREQ 2</b></p> <p>Sets the frequency limit used to stop the second auxiliary motor.</p> <ul style="list-style-type: none"> <li>See 8112 LOW FREQ 1 for a complete description of the operation.</li> </ul> <p>The second auxiliary motor stops if:</p> <ul style="list-style-type: none"> <li>Two auxiliary motors are running.</li> <li>ACS550 output frequency drops below the limit: 8113 - 1.</li> <li>Output frequency stays below the relaxed limit (8113 + 1 Hz) for at least the time: 8116 AUX MOT STOP D.</li> </ul>
8114	<p><b>LOW FREQ 3</b></p> <p>Sets the frequency limit used to stop the third auxiliary motor.</p> <ul style="list-style-type: none"> <li>See 8112 LOW FREQ 1 for a complete description of the operation.</li> </ul> <p>The third auxiliary motor stops if:</p> <ul style="list-style-type: none"> <li>Three auxiliary motors are running.</li> <li>ACS550 output frequency drops below the limit: 8114 - 1.</li> <li>Output frequency stays below the relaxed limit (8114 + 1 Hz) for at least the time: 8116 AUX MOT STOP D.</li> </ul>
8115	<p><b>AUX MOT START D</b></p> <p>Sets the Start Delay for the auxiliary motors.</p> <ul style="list-style-type: none"> <li>The output frequency must remain above the start frequency limit (parameter 8109, 8110, or 8111) for this time period before the auxiliary motor starts.</li> <li>See 8109 START FREQ 1 for a complete description of the operation.</li> </ul>
8116	<p><b>AUX MOT STOP D.</b></p> <p>Sets the Stop Delay for the auxiliary motors.</p> <ul style="list-style-type: none"> <li>The output frequency must remain below the low frequency limit (parameter 8112, 8113, or 8114) for this time period before the auxiliary motor stops.</li> <li>See 8112 LOW FREQ 1 for a complete description of the operation.</li> </ul>

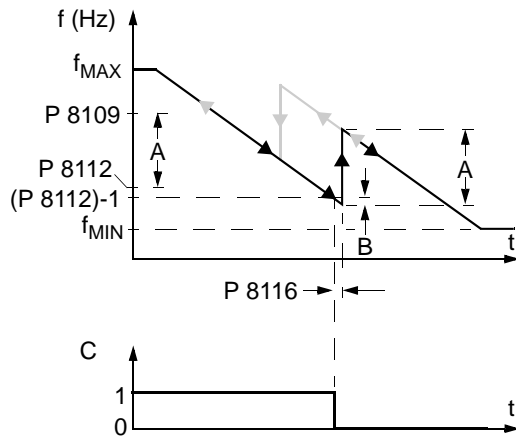

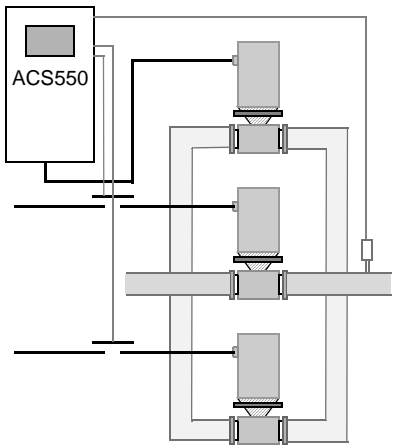
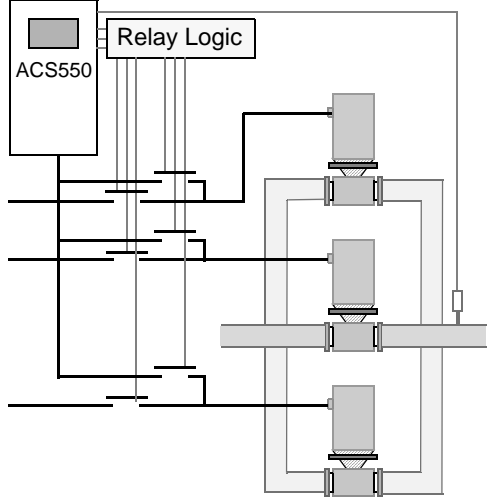
Code	Description
8117	<p><b>NR OF AUX MOT</b></p> <p>Sets the number of auxiliary motors.</p> <ul style="list-style-type: none"> <li>• Each auxiliary motor requires a relay output, which the drive uses to send start/stop signals.</li> <li>• The Autochange function, if used, requires an additional relay output for the speed regulated motor.</li> <li>• The following describes the set-up of the required relay outputs.</li> </ul> <p><b>Relay Outputs</b></p> <p>As noted above, each auxiliary motor requires a relay output, which the drive uses to send start/stop signals. The following describes how the drive keeps track of motors and relays.</p> <ul style="list-style-type: none"> <li>• The ACS550 provides relay outputs RO1...RO3.</li> <li>• An external digital output module can be added to provide relay outputs RO4...RO6.</li> <li>• Parameters 1401...1403 and 1410...1412 define, respectively, how relays RO1...RO6 are used – the parameter value 31 PFC defines the relay as used for PFC.</li> <li>• The ACS550 assigns auxiliary motors to relays in ascending order. If the Autochange function is disabled, the first auxiliary motor is the one connected to the first relay with a parameter setting = 31 PFC, and so on. If the Autochange function is used, the assignments rotate. Initially, the speed regulated motor is the one connected to the first relay with a parameter setting = 31 PFC, the first auxiliary motor is the one connected to the second relay with a parameter setting = 31 PFC, and so on.</li> </ul> <div style="display: flex; justify-content: space-around; align-items: flex-start;"> <div style="text-align: center;">  <p>Standard PFC mode</p> </div> <div style="text-align: center;">  <p>PFC with Autochange mode</p> </div> </div> <ul style="list-style-type: none"> <li>• The fourth auxiliary motor uses the same reference step, low frequency and start frequency values as the third auxiliary motor.</li> </ul>

Code	Description																																																																																																																																																																																																																																													
	<ul style="list-style-type: none"> <li>The table below shows the ACS550 PFC motor assignments for some typical settings in the Relay Output parameters (1401...1403 and 1410...1412), where the settings are either =31 (PFC), or =X (anything but 31), and where the Autochange function is disabled (8118 AUTOCHNG INTERV = 0).</li> </ul> <table border="1"> <thead> <tr> <th colspan="2">Parameter Setting</th> <th colspan="6">ACS550 Relay Assignment</th> </tr> <tr> <th>1</th><th>4</th><th>0</th><th>1</th><th>1</th><th>1</th><th>8</th> <th colspan="6">Autochange Disabled</th> </tr> <tr> <th>4</th><th>0</th><th>1</th><th>1</th><th>1</th><th>1</th><th>1</th> <th>RO1</th><th>RO2</th><th>RO3</th><th>RO4</th><th>RO5</th><th>RO6</th> </tr> <tr> <th>1</th><th>2</th><th>3</th><th>0</th><th>1</th><th>2</th><th>7</th> <th></th><th></th><th></th><th></th><th></th><th></th> </tr> </thead> <tbody> <tr> <td>31</td><td>X</td><td>X</td><td>X</td><td>X</td><td>X</td><td>1</td> <td>Aux.</td><td>X</td><td>X</td><td>X</td><td>X</td><td>X</td> </tr> <tr> <td>31</td><td>31</td><td>X</td><td>X</td><td>X</td><td>X</td><td>2</td> <td>Aux.</td><td>Aux.</td><td>X</td><td>X</td><td>X</td><td>X</td> </tr> <tr> <td>31</td><td>31</td><td>31</td><td>X</td><td>X</td><td>X</td><td>3</td> <td>Aux.</td><td>Aux.</td><td>Aux.</td><td>X</td><td>X</td><td>X</td> </tr> <tr> <td>X</td><td>31</td><td>31</td><td>X</td><td>X</td><td>X</td><td>2</td> <td>X</td><td>Aux.</td><td>Aux.</td><td>X</td><td>X</td><td>X</td> </tr> <tr> <td>X</td><td>X</td><td>X</td><td>31</td><td>X</td><td>31</td><td>2</td> <td>X</td><td>X</td><td>X</td><td>Aux.</td><td>X</td><td>Aux.</td> </tr> <tr> <td>31</td><td>31</td><td>X</td><td>X</td><td>X</td><td>X</td><td>1*</td> <td>Aux.</td><td>Aux.</td><td>X</td><td>X</td><td>X</td><td>X</td> </tr> </tbody> </table> <p>* = One additional relay output for the PFC that is in use. One motor is in "sleep" when the other is rotating.</p> <ul style="list-style-type: none"> <li>The table below shows the ACS550 PFC motor assignments for some typical settings in the Relay Output parameters (1401...1403 and 1410...1412), where the settings are either =31 (PFC), or =X (anything but 31), and where the Autochange function is enabled (8118 AUTOCHNG INTERV = value &gt; 0).</li> </ul> <table border="1"> <thead> <tr> <th colspan="2">Parameter Setting</th> <th colspan="6">ACS550 Relay Assignment</th> </tr> <tr> <th>1</th><th>4</th><th>0</th><th>1</th><th>1</th><th>1</th><th>8</th> <th colspan="6">Autochange Disabled</th> </tr> <tr> <th>4</th><th>0</th><th>1</th><th>1</th><th>1</th><th>1</th><th>1</th> <th>RO1</th><th>RO2</th><th>RO3</th><th>RO4</th><th>RO5</th><th>RO6</th> </tr> <tr> <th>1</th><th>2</th><th>3</th><th>0</th><th>1</th><th>2</th><th>7</th> <th></th><th></th><th></th><th></th><th></th><th></th> </tr> </thead> <tbody> <tr> <td>31</td><td>31</td><td>X</td><td>X</td><td>X</td><td>X</td><td>1</td> <td>PFC</td><td>PFC</td><td>X</td><td>X</td><td>X</td><td>X</td> </tr> <tr> <td>31</td><td>31</td><td>31</td><td>X</td><td>X</td><td>X</td><td>2</td> <td>PFC</td><td>PFC</td><td>PFC</td><td>X</td><td>X</td><td>X</td> </tr> <tr> <td>x</td><td>31</td><td>31</td><td>X</td><td>X</td><td>X</td><td>1</td> <td>X</td><td>PFC</td><td>PFC</td><td>X</td><td>X</td><td>X</td> </tr> <tr> <td>X</td><td>X</td><td>X</td><td>31</td><td>X</td><td>31</td><td>1</td> <td>X</td><td>X</td><td>X</td><td>PFC</td><td>X</td><td>PFC</td> </tr> <tr> <td>31</td><td>31</td><td>X</td><td>X</td><td>X</td><td>X</td><td>0**</td> <td>PFC</td><td>PFC</td><td>X</td><td>X</td><td>X</td><td>X</td> </tr> </tbody> </table> <p>** = No auxiliary motors, but the autochange function is in use. Working as a standard PID-control.</p>	Parameter Setting		ACS550 Relay Assignment						1	4	0	1	1	1	8	Autochange Disabled						4	0	1	1	1	1	1	RO1	RO2	RO3	RO4	RO5	RO6	1	2	3	0	1	2	7							31	X	X	X	X	X	1	Aux.	X	X	X	X	X	31	31	X	X	X	X	2	Aux.	Aux.	X	X	X	X	31	31	31	X	X	X	3	Aux.	Aux.	Aux.	X	X	X	X	31	31	X	X	X	2	X	Aux.	Aux.	X	X	X	X	X	X	31	X	31	2	X	X	X	Aux.	X	Aux.	31	31	X	X	X	X	1*	Aux.	Aux.	X	X	X	X	Parameter Setting		ACS550 Relay Assignment						1	4	0	1	1	1	8	Autochange Disabled						4	0	1	1	1	1	1	RO1	RO2	RO3	RO4	RO5	RO6	1	2	3	0	1	2	7							31	31	X	X	X	X	1	PFC	PFC	X	X	X	X	31	31	31	X	X	X	2	PFC	PFC	PFC	X	X	X	x	31	31	X	X	X	1	X	PFC	PFC	X	X	X	X	X	X	31	X	31	1	X	X	X	PFC	X	PFC	31	31	X	X	X	X	0**	PFC	PFC	X	X	X	X
Parameter Setting		ACS550 Relay Assignment																																																																																																																																																																																																																																												
1	4	0	1	1	1	8	Autochange Disabled																																																																																																																																																																																																																																							
4	0	1	1	1	1	1	RO1	RO2	RO3	RO4	RO5	RO6																																																																																																																																																																																																																																		
1	2	3	0	1	2	7																																																																																																																																																																																																																																								
31	X	X	X	X	X	1	Aux.	X	X	X	X	X																																																																																																																																																																																																																																		
31	31	X	X	X	X	2	Aux.	Aux.	X	X	X	X																																																																																																																																																																																																																																		
31	31	31	X	X	X	3	Aux.	Aux.	Aux.	X	X	X																																																																																																																																																																																																																																		
X	31	31	X	X	X	2	X	Aux.	Aux.	X	X	X																																																																																																																																																																																																																																		
X	X	X	31	X	31	2	X	X	X	Aux.	X	Aux.																																																																																																																																																																																																																																		
31	31	X	X	X	X	1*	Aux.	Aux.	X	X	X	X																																																																																																																																																																																																																																		
Parameter Setting		ACS550 Relay Assignment																																																																																																																																																																																																																																												
1	4	0	1	1	1	8	Autochange Disabled																																																																																																																																																																																																																																							
4	0	1	1	1	1	1	RO1	RO2	RO3	RO4	RO5	RO6																																																																																																																																																																																																																																		
1	2	3	0	1	2	7																																																																																																																																																																																																																																								
31	31	X	X	X	X	1	PFC	PFC	X	X	X	X																																																																																																																																																																																																																																		
31	31	31	X	X	X	2	PFC	PFC	PFC	X	X	X																																																																																																																																																																																																																																		
x	31	31	X	X	X	1	X	PFC	PFC	X	X	X																																																																																																																																																																																																																																		
X	X	X	31	X	31	1	X	X	X	PFC	X	PFC																																																																																																																																																																																																																																		
31	31	X	X	X	X	0**	PFC	PFC	X	X	X	X																																																																																																																																																																																																																																		
8118	<p><b>AUTOCHNG INTERV</b></p> <p>Controls operation of the Autochange function and sets the interval between changes.</p> <ul style="list-style-type: none"> <li>The Autochange time interval only applies to the time when the speed regulated motor is running.</li> <li>See parameter 8119 AUTOCHNG LEVEL for an overview of the Autochange function.</li> <li>The drive always coasts to a stop when autochange is performed.</li> <li>Autochange enabled requires parameter 8120 INTERLOCKS = value &gt; 0.</li> </ul> <p>0.0 = NOT SEL – Disables the Autochange function.                      0.1...336 = The operating time interval (the time when the start signal is on) between automatic motor changes.</p> <p><b>Warning! When enabled, the Autochange function requires the interlocks (8120 interlocks = value &gt; 0) enabled. During autochange the interlocks interrupt the drive's power output, preventing damage to the contacts.</b></p>																																																																																																																																																																																																																																													
	<p>PFC with Autochange mode</p>																																																																																																																																																																																																																																													

Code	Description
8119	<p><b>AUTOCHNG LEVEL</b></p> <p>Sets an upper limit, as a percent of output capacity, for the autochange logic. When the output from the PID/PFC control block exceeds this limit, autochange is prevented. For example, use this parameter to deny autochange when the Pump-Fan system is operating near maximum capacity.</p> <p><b>Autochange Overview</b></p> <p>The purpose of the autochange operation is to equalize duty time between multiple motors used in a system. At each autochange operation:</p> <ul style="list-style-type: none"> <li>• A different motor takes a turn connected to the ACS550 output – the speed regulated motor.</li> <li>• The starting order of the other motors rotates.</li> </ul> <p>The Autochange function requires:</p> <ul style="list-style-type: none"> <li>• External switchgear for changing the drive's output power connections.</li> <li>• Parameter 8120 INTERLOCKS = value &gt; 0.</li> </ul> <p>Autochange is performed when:</p> <ul style="list-style-type: none"> <li>• The running time since the previous autochange reaches the time set by 8118 AUTOCHNG INTERV</li> <li>• The PFC input is below the level set by this parameter, 8119 AUTOCHNG LEVEL.</li> </ul> <p><b>Note!</b> The ACS550 always coasts to stop when autochange is performed.</p> <p>In an autochange, the Autochange function does all of the following (see figure):</p> <ul style="list-style-type: none"> <li>• Initiates a change when the running time, since the last autochange, reaches 8118 AUTOCHNG INTERV, and PFC input is below limit 8119 AUTOCHNG LEVEL.</li> <li>• Stops the speed regulated motor.</li> <li>• Switches off the contactor of the speed regulated motor.</li> <li>• Increments the starting order counter, to change the starting order for the motors.</li> <li>• Identifies the next motor in line to be the speed regulated motor.</li> <li>• Switches off the above motor's contactor, if the motor was running. Any other running motors are not interrupted.</li> <li>• Switches on the contactor of the new speed regulated motor. The autochange switchgear connects this motor to the ACS550 power output.</li> <li>• Delays motor start for the time 8122 PFC START DELAY.</li> <li>• Starts the speed regulated motor.</li> <li>• Identifies the next constant speed motor in the rotation.</li> <li>• Switches the above motor on, but only if the new speed regulated motor had been running (as a constant speed motor) – This step keeps an equal number of motors running before and after autochange.</li> <li>• Continues with normal PFC operation.</li> </ul> <p><b>Starting Order Counter</b></p> <p>The operation of the starting-order counter:</p> <ul style="list-style-type: none"> <li>• The relay output parameter definitions (1401...1403 and 1410...1412) establish the initial motor sequence. (The lowest parameter number with a value 31 (PFC) identifies the relay connected to 1PFC, the first motor, and so on.)</li> <li>• Initially, 1PFC = speed regulated motor, 2PFC = 1st auxiliary motor, etc.</li> <li>• The first autochange shifts the sequence to: 2PFC = speed regulated motor, 3PFC = 1st auxiliary motor, ..., 1PFC = last auxiliary motor.</li> <li>• The next autochange shifts the sequence again, and so on.</li> <li>• If the autochange cannot start a needed motor because all inactive motors are interlocked, the drive displays an alarm (2015, PFC INTERLOCK).</li> <li>• When ACS550 power supply is switched off, the counter preserves the current Autochange rotation positions in permanent memory. When power is restored, the Autochange rotation starts at the position stored in memory.</li> <li>• If the PFC relay configuration is changed (or if the PFC enable value is changed), the rotation is reset. (See the first bullet above.)</li> </ul>

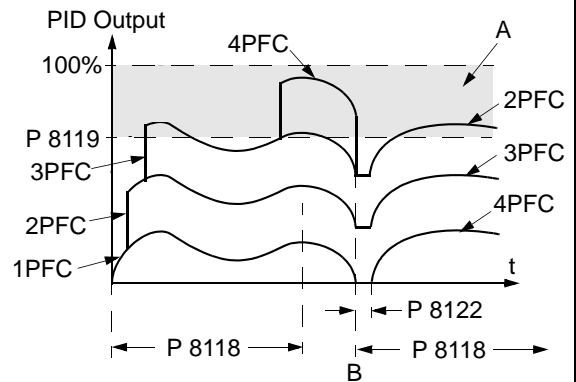

A = Area above 8119 AUTOCHNG LEVEL – autochange not allowed.  
 B = Autochange occurs.  
 1PFC, etc. = PID output associated with each motor.

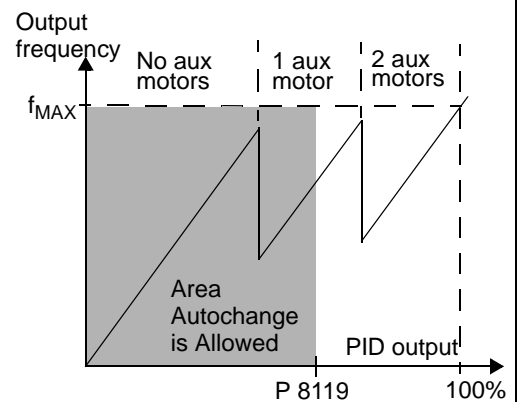

Code	Description																								
8120	<p><b>INTERLOCKS</b></p> <p>Defines operation of the Interlock function. When the Interlock function is enabled:</p> <ul style="list-style-type: none"> <li>• An interlock is active when its command signal is absent.</li> <li>• An interlock is inactive when its command signal is present.</li> <li>• The ACS550 will not start if a start command occurs when the speed regulated motor's interlock is active – the control panel displays an alarm (2015, PFC INTERLOCK).</li> </ul> <p>Wire each Interlock circuit as follows:</p> <ul style="list-style-type: none"> <li>• Wire a contact of the motor's On/Off switch to the Interlock circuit – the drive's PFC logic can then recognize that the motor is switched off, and start the next available motor.</li> <li>• Wire a contact of the motor thermal relay (or other protective device in the motor circuit) to the Interlock input – the drive's PFC logic can then recognize that a motor fault is activated and stop the motor.</li> </ul> <p>0 = NOT SEL – Disables the Interlock function. All digital inputs are available for other purposes.</p> <ul style="list-style-type: none"> <li>• Requires 8118 AUTOCHNG INTERV = 0 (The Autochange function must be disabled if Interlock function is disabled.)</li> </ul> <p>1 = DI1 – Enables the Interlock function, and assigns a digital input (starting with DI1) to the interlock signal for each PFC relay. These assignments are defined in the following table and depend on:</p> <ul style="list-style-type: none"> <li>• The number of PFC relays (number of parameters 1401...1403 and 1410...1412) and with value = 31 PFC)</li> <li>• The Autochange function status (disabled if 8118 AUTOCHNG INTERV = 0, and otherwise enabled).</li> </ul> <table border="1" style="width: 100%; border-collapse: collapse;"> <thead> <tr> <th style="background-color: #d3d3d3;">No. PFC Relays</th> <th style="background-color: #d3d3d3;">Autochange Disabled (P 8118)</th> <th style="background-color: #d3d3d3;">Autochange Enabled (P 8118)</th> </tr> </thead> <tbody> <tr> <td style="text-align: center;">0</td> <td>DI1: Speed Reg Motor DI2...DI6: Free</td> <td>Not allowed</td> </tr> <tr> <td style="text-align: center;">1</td> <td>DI1: Speed Reg Motor DI2: First PFC Relay DI3...DI6: Free</td> <td>DI1: First PFC Relay DI2...DI6: Free</td> </tr> <tr> <td style="text-align: center;">2</td> <td>DI1: Speed Reg Motor DI2: First PFC Relay DI3: Second PFC Relay DI4...DI6: Free</td> <td>DI1: First PFC Relay DI2: Second PFC Relay DI3...DI6: Free</td> </tr> <tr> <td style="text-align: center;">3</td> <td>DI1: Speed Reg Motor DI2: First PFC Relay DI3: Second PFC Relay DI4: Third PFC Relay DI5...DI6: Free</td> <td>DI1: First PFC Relay DI2: Second PFC Relay DI3: Third PFC Relay DI4...DI6: Free</td> </tr> <tr> <td style="text-align: center;">4</td> <td>DI1: Speed Reg Motor DI2: First PFC Relay DI3: Second PFC Relay DI4: Third PFC Relay DI5: Fourth PFC Relay DI6: Free</td> <td>DI1: First PFC Relay DI2: Second PFC Relay DI3: Third PFC Relay DI4: Fourth PFC Relay DI5...DI6: Free</td> </tr> <tr> <td style="text-align: center;">5</td> <td>DI1: Speed Reg Motor DI2: First PFC Relay DI3: Second PFC Relay DI4: Third PFC Relay DI5: Fourth PFC Relay DI6: Fifth PFC Relay</td> <td>DI1: First PFC Relay DI2: Second PFC Relay DI3: Third PFC Relay DI4: Fourth PFC Relay DI5: Fifth PFC Relay DI6: Free</td> </tr> <tr> <td style="text-align: center;">6</td> <td>Not allowed</td> <td>DI1: First PFC Relay DI2: Second PFC Relay DI3: Third PFC Relay DI4: Fourth PFC Relay DI5: Fifth PFC Relay DI6: Sixth PFC Relay</td> </tr> </tbody> </table>	No. PFC Relays	Autochange Disabled (P 8118)	Autochange Enabled (P 8118)	0	DI1: Speed Reg Motor DI2...DI6: Free	Not allowed	1	DI1: Speed Reg Motor DI2: First PFC Relay DI3...DI6: Free	DI1: First PFC Relay DI2...DI6: Free	2	DI1: Speed Reg Motor DI2: First PFC Relay DI3: Second PFC Relay DI4...DI6: Free	DI1: First PFC Relay DI2: Second PFC Relay DI3...DI6: Free	3	DI1: Speed Reg Motor DI2: First PFC Relay DI3: Second PFC Relay DI4: Third PFC Relay DI5...DI6: Free	DI1: First PFC Relay DI2: Second PFC Relay DI3: Third PFC Relay DI4...DI6: Free	4	DI1: Speed Reg Motor DI2: First PFC Relay DI3: Second PFC Relay DI4: Third PFC Relay DI5: Fourth PFC Relay DI6: Free	DI1: First PFC Relay DI2: Second PFC Relay DI3: Third PFC Relay DI4: Fourth PFC Relay DI5...DI6: Free	5	DI1: Speed Reg Motor DI2: First PFC Relay DI3: Second PFC Relay DI4: Third PFC Relay DI5: Fourth PFC Relay DI6: Fifth PFC Relay	DI1: First PFC Relay DI2: Second PFC Relay DI3: Third PFC Relay DI4: Fourth PFC Relay DI5: Fifth PFC Relay DI6: Free	6	Not allowed	DI1: First PFC Relay DI2: Second PFC Relay DI3: Third PFC Relay DI4: Fourth PFC Relay DI5: Fifth PFC Relay DI6: Sixth PFC Relay
No. PFC Relays	Autochange Disabled (P 8118)	Autochange Enabled (P 8118)																							
0	DI1: Speed Reg Motor DI2...DI6: Free	Not allowed																							
1	DI1: Speed Reg Motor DI2: First PFC Relay DI3...DI6: Free	DI1: First PFC Relay DI2...DI6: Free																							
2	DI1: Speed Reg Motor DI2: First PFC Relay DI3: Second PFC Relay DI4...DI6: Free	DI1: First PFC Relay DI2: Second PFC Relay DI3...DI6: Free																							
3	DI1: Speed Reg Motor DI2: First PFC Relay DI3: Second PFC Relay DI4: Third PFC Relay DI5...DI6: Free	DI1: First PFC Relay DI2: Second PFC Relay DI3: Third PFC Relay DI4...DI6: Free																							
4	DI1: Speed Reg Motor DI2: First PFC Relay DI3: Second PFC Relay DI4: Third PFC Relay DI5: Fourth PFC Relay DI6: Free	DI1: First PFC Relay DI2: Second PFC Relay DI3: Third PFC Relay DI4: Fourth PFC Relay DI5...DI6: Free																							
5	DI1: Speed Reg Motor DI2: First PFC Relay DI3: Second PFC Relay DI4: Third PFC Relay DI5: Fourth PFC Relay DI6: Fifth PFC Relay	DI1: First PFC Relay DI2: Second PFC Relay DI3: Third PFC Relay DI4: Fourth PFC Relay DI5: Fifth PFC Relay DI6: Free																							
6	Not allowed	DI1: First PFC Relay DI2: Second PFC Relay DI3: Third PFC Relay DI4: Fourth PFC Relay DI5: Fifth PFC Relay DI6: Sixth PFC Relay																							

Code	Description																								
	<p>2 = DI2 – Enables the Interlock function, and assigns a digital input (starting with DI2) to the interlock signal for each PFC relay. These assignments are defined in the following table and depend on:</p> <ul style="list-style-type: none"> <li>• The number of PFC relays (number of parameters 1401...1403 and 1410...1412) with value = 31 PFC)</li> <li>• The Autochange function status (disabled if 8118 AUTOCHNG INTERV = 0, and otherwise enabled).</li> </ul>																								
	<table border="1"> <thead> <tr> <th>No. PFC Relays</th> <th>Autochange Disabled (P 8118)</th> <th>Autochange Enabled (P 8118)</th> </tr> </thead> <tbody> <tr> <td>0</td> <td>DI1: Free DI2: Speed Reg Motor DI3...DI6: Free</td> <td>Not allowed</td> </tr> <tr> <td>1</td> <td>DI1: Free DI2: Speed Reg Motor DI3: First PFC Relay DI4...DI6: Free</td> <td>DI1: Free DI2: First PFC Relay DI3...DI6: Free</td> </tr> <tr> <td>2</td> <td>DI1: Free DI2: Speed Reg Motor DI3: First PFC Relay DI4: Second PFC Relay DI5...DI6: Free</td> <td>DI1: Free DI2: First PFC Relay DI3: Second PFC Relay DI4...DI6: Free</td> </tr> <tr> <td>3</td> <td>DI1: Free DI2: Speed Reg Motor DI3: First PFC Relay DI4: Second PFC Relay DI5: Third PFC Relay DI6: Free</td> <td>DI1: Free DI2: First PFC Relay DI3: Second PFC Relay DI4: Third PFC Relay DI5...DI6: Free</td> </tr> <tr> <td>4</td> <td>DI1: Free DI2: Speed Reg Motor DI3: First PFC Relay DI4: Second PFC Relay DI5: Third PFC Relay DI6: Fourth PFC Relay</td> <td>DI1: Free DI2: First PFC Relay DI3: Second PFC Relay DI4: Third PFC Relay DI5: Fourth PFC Relay DI6: Free</td> </tr> <tr> <td>5</td> <td>Not allowed</td> <td>DI1: Free DI2: First PFC Relay DI3: Second PFC Relay DI4: Third PFC Relay DI5: Fourth PFC Relay DI6: Fifth PFC Relay</td> </tr> <tr> <td>6</td> <td>Not allowed</td> <td>Not allowed</td> </tr> </tbody> </table>	No. PFC Relays	Autochange Disabled (P 8118)	Autochange Enabled (P 8118)	0	DI1: Free DI2: Speed Reg Motor DI3...DI6: Free	Not allowed	1	DI1: Free DI2: Speed Reg Motor DI3: First PFC Relay DI4...DI6: Free	DI1: Free DI2: First PFC Relay DI3...DI6: Free	2	DI1: Free DI2: Speed Reg Motor DI3: First PFC Relay DI4: Second PFC Relay DI5...DI6: Free	DI1: Free DI2: First PFC Relay DI3: Second PFC Relay DI4...DI6: Free	3	DI1: Free DI2: Speed Reg Motor DI3: First PFC Relay DI4: Second PFC Relay DI5: Third PFC Relay DI6: Free	DI1: Free DI2: First PFC Relay DI3: Second PFC Relay DI4: Third PFC Relay DI5...DI6: Free	4	DI1: Free DI2: Speed Reg Motor DI3: First PFC Relay DI4: Second PFC Relay DI5: Third PFC Relay DI6: Fourth PFC Relay	DI1: Free DI2: First PFC Relay DI3: Second PFC Relay DI4: Third PFC Relay DI5: Fourth PFC Relay DI6: Free	5	Not allowed	DI1: Free DI2: First PFC Relay DI3: Second PFC Relay DI4: Third PFC Relay DI5: Fourth PFC Relay DI6: Fifth PFC Relay	6	Not allowed	Not allowed
No. PFC Relays	Autochange Disabled (P 8118)	Autochange Enabled (P 8118)																							
0	DI1: Free DI2: Speed Reg Motor DI3...DI6: Free	Not allowed																							
1	DI1: Free DI2: Speed Reg Motor DI3: First PFC Relay DI4...DI6: Free	DI1: Free DI2: First PFC Relay DI3...DI6: Free																							
2	DI1: Free DI2: Speed Reg Motor DI3: First PFC Relay DI4: Second PFC Relay DI5...DI6: Free	DI1: Free DI2: First PFC Relay DI3: Second PFC Relay DI4...DI6: Free																							
3	DI1: Free DI2: Speed Reg Motor DI3: First PFC Relay DI4: Second PFC Relay DI5: Third PFC Relay DI6: Free	DI1: Free DI2: First PFC Relay DI3: Second PFC Relay DI4: Third PFC Relay DI5...DI6: Free																							
4	DI1: Free DI2: Speed Reg Motor DI3: First PFC Relay DI4: Second PFC Relay DI5: Third PFC Relay DI6: Fourth PFC Relay	DI1: Free DI2: First PFC Relay DI3: Second PFC Relay DI4: Third PFC Relay DI5: Fourth PFC Relay DI6: Free																							
5	Not allowed	DI1: Free DI2: First PFC Relay DI3: Second PFC Relay DI4: Third PFC Relay DI5: Fourth PFC Relay DI6: Fifth PFC Relay																							
6	Not allowed	Not allowed																							

Code	Description																																							
	<p>3 = DI3 – Enables the Interlocks function, and assigns a digital input (starting with DI3) to the interlock signal for each PFC relay. These assignments are defined in the following table and depend on:</p> <ul style="list-style-type: none"> <li>• The number of PFC relays (number of parameters 1401...1403 and 1410...1412) with value = 31 PFC)</li> <li>• The Autochange function status (disabled if 8118 AUTOCHNG INTERV = 0, and otherwise enabled).</li> </ul> <table border="1"> <thead> <tr> <th>No. PFC Relays</th> <th>Autochange Disabled (P 8118)</th> <th>Autochange Enabled (P 8118)</th> </tr> </thead> <tbody> <tr> <td>0</td> <td>DI1...DI2: Free DI3: Speed Reg Motor DI4...DI6: Free</td> <td>Not allowed</td> </tr> <tr> <td>1</td> <td>DI1...DI2: Free DI3: Speed Reg Motor DI4: First PFC Relay DI5...DI6: Free</td> <td>DI1...DI2: Free DI3: First PFC Relay DI4...DI6: Free</td> </tr> <tr> <td>2</td> <td>DI1...DI2: Free DI3: Speed Reg Motor DI4: First PFC Relay DI5: Second PFC Relay DI6: Free</td> <td>DI1...DI2: Free DI3: First PFC Relay DI4: Second PFC Relay DI5...DI6: Free</td> </tr> <tr> <td>3</td> <td>DI1...DI2: Free DI3: Speed Reg Motor DI4: First PFC Relay DI5: Second PFC Relay DI6: Third PFC Relay</td> <td>DI1...DI2: Free DI3: First PFC Relay DI4: Second PFC Relay DI5: Third PFC Relay DI6: Free</td> </tr> <tr> <td>4</td> <td>Not allowed</td> <td>DI1...DI2: Free DI3: First PFC Relay DI4: Second PFC Relay DI5: Third PFC Relay DI6: Fourth PFC Relay</td> </tr> <tr> <td>5...6</td> <td>Not allowed</td> <td>Not allowed</td> </tr> </tbody> </table> <p>4 = DI4 – Enables the Interlock function, and assigns a digital input (starting with DI4) to the interlock signal for each PFC relay. These assignments are defined in the following table and depend on:</p> <ul style="list-style-type: none"> <li>• The number of PFC relays (number of parameters 1401...1403 and 1410...1412) with value = 31 PFC)</li> <li>• The Autochange function status (disabled if 8118 AUTOCHNG INTERV = 0, and otherwise enabled).</li> </ul> <table border="1"> <thead> <tr> <th>No. PFC Relays</th> <th>Autochange Disabled (P 8118)</th> <th>Autochange Enabled (P 8118)</th> </tr> </thead> <tbody> <tr> <td>0</td> <td>DI1...DI3: Free DI4: Speed Reg Motor DI5...DI6: Free</td> <td>Not allowed</td> </tr> <tr> <td>1</td> <td>DI1...DI3: Free DI4: Speed Reg Motor DI5: First PFC Relay DI6: Free</td> <td>DI1...DI3: Free DI4: First PFC Relay DI5...DI6: Free</td> </tr> <tr> <td>2</td> <td>DI1...DI3: Free DI4: Speed Reg Motor DI5: First PFC Relay DI6: Second PFC Relay</td> <td>DI1...DI3: Free DI4: First PFC Relay DI5: Second PFC Relay DI6: Free</td> </tr> <tr> <td>3</td> <td>Not allowed</td> <td>DI1...DI3: Free DI4: First PFC Relay DI5: Second PFC Relay DI6: Third PFC Relay</td> </tr> <tr> <td>4...6</td> <td>Not allowed</td> <td>Not allowed</td> </tr> </tbody> </table>	No. PFC Relays	Autochange Disabled (P 8118)	Autochange Enabled (P 8118)	0	DI1...DI2: Free DI3: Speed Reg Motor DI4...DI6: Free	Not allowed	1	DI1...DI2: Free DI3: Speed Reg Motor DI4: First PFC Relay DI5...DI6: Free	DI1...DI2: Free DI3: First PFC Relay DI4...DI6: Free	2	DI1...DI2: Free DI3: Speed Reg Motor DI4: First PFC Relay DI5: Second PFC Relay DI6: Free	DI1...DI2: Free DI3: First PFC Relay DI4: Second PFC Relay DI5...DI6: Free	3	DI1...DI2: Free DI3: Speed Reg Motor DI4: First PFC Relay DI5: Second PFC Relay DI6: Third PFC Relay	DI1...DI2: Free DI3: First PFC Relay DI4: Second PFC Relay DI5: Third PFC Relay DI6: Free	4	Not allowed	DI1...DI2: Free DI3: First PFC Relay DI4: Second PFC Relay DI5: Third PFC Relay DI6: Fourth PFC Relay	5...6	Not allowed	Not allowed	No. PFC Relays	Autochange Disabled (P 8118)	Autochange Enabled (P 8118)	0	DI1...DI3: Free DI4: Speed Reg Motor DI5...DI6: Free	Not allowed	1	DI1...DI3: Free DI4: Speed Reg Motor DI5: First PFC Relay DI6: Free	DI1...DI3: Free DI4: First PFC Relay DI5...DI6: Free	2	DI1...DI3: Free DI4: Speed Reg Motor DI5: First PFC Relay DI6: Second PFC Relay	DI1...DI3: Free DI4: First PFC Relay DI5: Second PFC Relay DI6: Free	3	Not allowed	DI1...DI3: Free DI4: First PFC Relay DI5: Second PFC Relay DI6: Third PFC Relay	4...6	Not allowed	Not allowed
No. PFC Relays	Autochange Disabled (P 8118)	Autochange Enabled (P 8118)																																						
0	DI1...DI2: Free DI3: Speed Reg Motor DI4...DI6: Free	Not allowed																																						
1	DI1...DI2: Free DI3: Speed Reg Motor DI4: First PFC Relay DI5...DI6: Free	DI1...DI2: Free DI3: First PFC Relay DI4...DI6: Free																																						
2	DI1...DI2: Free DI3: Speed Reg Motor DI4: First PFC Relay DI5: Second PFC Relay DI6: Free	DI1...DI2: Free DI3: First PFC Relay DI4: Second PFC Relay DI5...DI6: Free																																						
3	DI1...DI2: Free DI3: Speed Reg Motor DI4: First PFC Relay DI5: Second PFC Relay DI6: Third PFC Relay	DI1...DI2: Free DI3: First PFC Relay DI4: Second PFC Relay DI5: Third PFC Relay DI6: Free																																						
4	Not allowed	DI1...DI2: Free DI3: First PFC Relay DI4: Second PFC Relay DI5: Third PFC Relay DI6: Fourth PFC Relay																																						
5...6	Not allowed	Not allowed																																						
No. PFC Relays	Autochange Disabled (P 8118)	Autochange Enabled (P 8118)																																						
0	DI1...DI3: Free DI4: Speed Reg Motor DI5...DI6: Free	Not allowed																																						
1	DI1...DI3: Free DI4: Speed Reg Motor DI5: First PFC Relay DI6: Free	DI1...DI3: Free DI4: First PFC Relay DI5...DI6: Free																																						
2	DI1...DI3: Free DI4: Speed Reg Motor DI5: First PFC Relay DI6: Second PFC Relay	DI1...DI3: Free DI4: First PFC Relay DI5: Second PFC Relay DI6: Free																																						
3	Not allowed	DI1...DI3: Free DI4: First PFC Relay DI5: Second PFC Relay DI6: Third PFC Relay																																						
4...6	Not allowed	Not allowed																																						

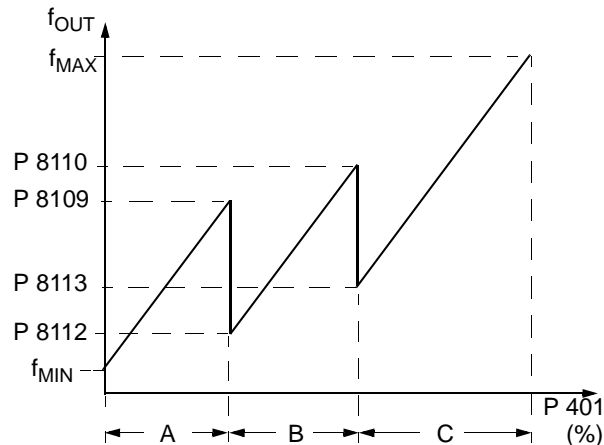
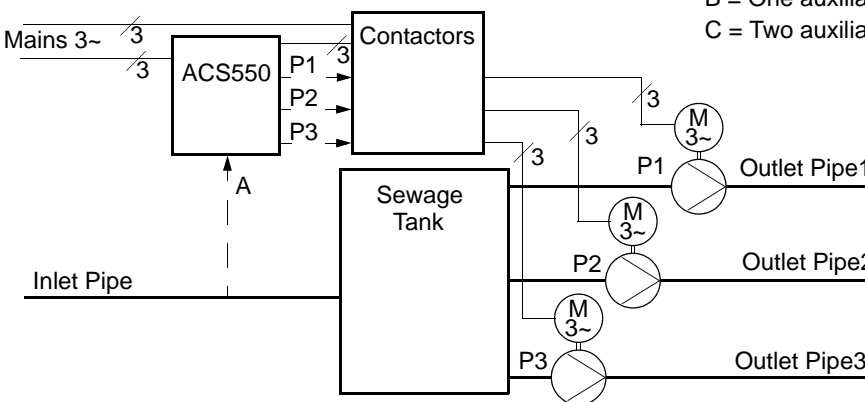

Code	Description																											
	<p>5 = DI5 – Enables the Interlock function, and assigns a digital input (starting with DI5) to the interlock signal for each PFC relay. These assignments are defined in the following table and depend on:</p> <ul style="list-style-type: none"> <li>• The number of PFC relays (number of parameters 1401...1403 and 1410...1412) with value = 31 PFC)</li> <li>• The Autochange function status (disabled if 8118 AUTOCHNG INTERV = 0, and otherwise enabled).</li> </ul> <table border="1"> <thead> <tr> <th>No. PFC Relays</th> <th>Autochange Disabled (P 8118)</th> <th>Autochange Enabled (P 8118)</th> </tr> </thead> <tbody> <tr> <td>0</td> <td>DI1...DI4: Free DI5: Speed Reg Motor DI6: Free</td> <td>Not allowed</td> </tr> <tr> <td>1</td> <td>DI1...DI4: Free DI5: Speed Reg Motor DI6: First PFC Relay</td> <td>DI1...DI4: Free DI5: First PFC Relay DI6: Free</td> </tr> <tr> <td>2</td> <td>Not allowed</td> <td>DI1...DI4: Free DI5: First PFC Relay DI6: Second PFC Relay</td> </tr> <tr> <td>3...6</td> <td>Not allowed</td> <td>Not allowed</td> </tr> </tbody> </table> <p>6 = DI6 – Enables the Interlock function, and assigns digital input DI6 to the interlock signal for the speed regulated motor.</p> <ul style="list-style-type: none"> <li>• Requires 8118 AUTOCHNG INTERV = 0.</li> </ul> <table border="1"> <thead> <tr> <th>No. PFC Relays</th> <th>Autochange Disabled</th> <th>Autochange Enabled</th> </tr> </thead> <tbody> <tr> <td>0</td> <td>DI1...DI5: Free DI6: Speed Reg Motor</td> <td>Not allowed</td> </tr> <tr> <td>1</td> <td>Not allowed</td> <td>DI1...DI5: Free DI6: First PFC Relay</td> </tr> <tr> <td>2...6</td> <td>Not allowed</td> <td>Not allowed</td> </tr> </tbody> </table>	No. PFC Relays	Autochange Disabled (P 8118)	Autochange Enabled (P 8118)	0	DI1...DI4: Free DI5: Speed Reg Motor DI6: Free	Not allowed	1	DI1...DI4: Free DI5: Speed Reg Motor DI6: First PFC Relay	DI1...DI4: Free DI5: First PFC Relay DI6: Free	2	Not allowed	DI1...DI4: Free DI5: First PFC Relay DI6: Second PFC Relay	3...6	Not allowed	Not allowed	No. PFC Relays	Autochange Disabled	Autochange Enabled	0	DI1...DI5: Free DI6: Speed Reg Motor	Not allowed	1	Not allowed	DI1...DI5: Free DI6: First PFC Relay	2...6	Not allowed	Not allowed
No. PFC Relays	Autochange Disabled (P 8118)	Autochange Enabled (P 8118)																										
0	DI1...DI4: Free DI5: Speed Reg Motor DI6: Free	Not allowed																										
1	DI1...DI4: Free DI5: Speed Reg Motor DI6: First PFC Relay	DI1...DI4: Free DI5: First PFC Relay DI6: Free																										
2	Not allowed	DI1...DI4: Free DI5: First PFC Relay DI6: Second PFC Relay																										
3...6	Not allowed	Not allowed																										
No. PFC Relays	Autochange Disabled	Autochange Enabled																										
0	DI1...DI5: Free DI6: Speed Reg Motor	Not allowed																										
1	Not allowed	DI1...DI5: Free DI6: First PFC Relay																										
2...6	Not allowed	Not allowed																										

Code	Description
8121	<p><b>REG BYPASS CTRL</b></p> <p>Selects Regulator by-pass control. When enabled, Regulator by-pass control provides a simple control mechanism without a PID regulator.</p> <ul style="list-style-type: none"> <li>Use Regulator by-pass control only in special applications.</li> </ul> <p>0 = NO – Disables Regulator by-pass control. The drive uses the normal PFC reference: 1106 REF2 SELECT.</p> <p>1 = YES – Enables Regulator by-pass control.</p> <ul style="list-style-type: none"> <li>The process PID regulator is bypassed. Actual value of PID is used as the PFC reference (input). Normally EXT REF2 is used as the PFC reference.</li> <li>The drive uses the feedback signal defined by 4014 FBK SEL (or 4114) for the PFC frequency reference.</li> <li>The figure shows the relation between the control signal 4014 FBK SEL (OR 4114) and the speed regulated motor's frequency in a three-motor system.</li> </ul> <p>Example: In the diagram below, the pumping station's outlet flow is controlled by the measured inlet flow (A).</p>  <p>A = No auxiliary motors running          B = One auxiliary motor running          C = Two auxiliary motors running</p> 
8122	<p><b>PFC START DELAY</b></p> <p>Sets the start delay for speed regulated motors in the system. Using the delay, the drive works as follows:</p> <ul style="list-style-type: none"> <li>Switches on the contactor of the speed regulated motor – connecting the motor to the ACS550 power output.</li> <li>Delays motor start for the time 8122 PFC START DELAY.</li> <li>Starts the speed regulated motor.</li> <li>Starts auxiliary motors. See parameter 8115 for delay.</li> </ul> <p><b>Warning! Motors equipped with star-delta starters require a PFC Start Delay.</b></p> <ul style="list-style-type: none"> <li>After the ACS550 relay switches a motor On, the star-delta starter must switch to the star-connection and then back to the delta-connection before the drive applies power.</li> <li>So, the PFC Start Delay must be longer than the time setting of the star-delta starter.</li> </ul>
8123	<p><b>PFC ENABLE</b></p> <p>Selects PFC control. When enabled, PFC control:</p> <ul style="list-style-type: none"> <li>Switches in, or out, auxiliary constant speed motors as output demand increases or decreases. Parameters 8109 START FREQ 1 to 8114 LOW FREQ 3 define the switch points in terms of the drive output frequency.</li> <li>Adjusts the speed regulated motor output down, as auxiliary motors are added, and adjusts the speed regulated motor output up, as auxiliary motors are taken off line.</li> <li>Provides Interlock functions, if enabled.</li> <li>Requires 9904 MOTOR CTRL MODE = 3 SCALAR.</li> </ul> <p>0 = NOT SEL – Disables PFC control.</p> <p>1 = ACTIVE – Enables PFC control.</p>

Code	Description
8124	<p><b>ACC IN AUX STOP</b></p> <p>Sets the PFC acceleration time for a zero-to-maximum frequency ramp. This PFC acceleration ramp:</p> <ul style="list-style-type: none"> <li>• Applies to the speed regulated motor, when an auxiliary motor is switched off.</li> <li>• Replaces the acceleration ramp defined in Group 22: Accel / Decel.</li> <li>• Applies only until the output of the regulated motor increases by an amount equal to the output of the switched off auxiliary motor. Then the acceleration ramp defined in Group 22: Accel / Decel applies.</li> </ul> <p>0 = NOT SEL. 0.1...1800 = Activates this function using the value entered as the acceleration time.</p>
8125	<p><b>DEC IN AUX START</b></p> <p>Sets the PFC deceleration time for a maximum-to-zero frequency ramp. This PFC deceleration ramp:</p> <ul style="list-style-type: none"> <li>• Applies to the speed regulated motor, when an auxiliary motor is switched on.</li> <li>• Replaces the deceleration ramp defined in Group 22 ACCEL / DECEL.</li> <li>• Applies only until the output of the regulated motor decreases by an amount equal to the output of the auxiliary motor. Then the deceleration ramp defined in Group 22 ACCEL / DECEL applies.</li> </ul> <p>0 = NOT SEL. 0.1...1800 = Activates this function using the value entered as the deceleration time.</p>
8126	<p><b>TIMED AUTOCHNG</b></p> <p>Sets the autochange using the Timer function. See parameter 8119 AUTOCHANGE LEVEL.</p> <p>0 = NOT SEL. 1 = TIMER FUNCTION 1 – Enables autochange when Timer function 1 is active. 2...4 = TIMER FUNCTION 2...4 – Enables autochange when Timer function 2...4 is active.</p>
8127	<p><b>MOTORS</b></p> <p>Sets the actual number of PFC controlled motors (maximum 7 motors, 1 speed regulated, 3 connected direct-on-line and 3 spare motors).</p> <ul style="list-style-type: none"> <li>• This value includes also the speed regulated motor.</li> <li>• This value must be compatible with number of relays allocated to PFC if the autochange function is used.</li> <li>• If Autochange function is not used, the speed regulated motor does not need to have a relay output allocated to PFC but it needs to be included in this value.</li> </ul>

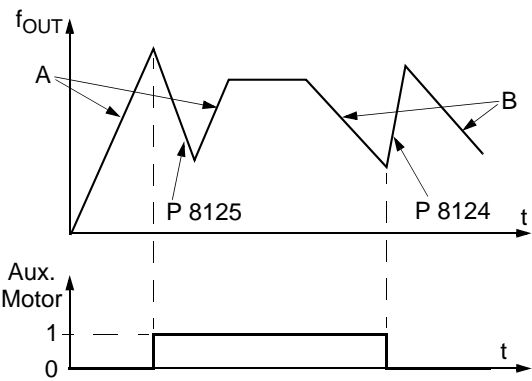

- A = speed regulated motor accelerating using Group 22 parameters (2202 or 2205).
- B = speed regulated motor decelerating using Group 22 parameters (2203 or 2206).
- At aux. motor start, speed regulated motor decelerates using 8125 DEC IN AUX START.
- At aux. motor stop, speed regulated motor accelerates using 8124 ACC IN AUX STOP.

### Group 98: Options

This group configures for options, in particular, enabling serial communication with the drive.

Code	Description
9802	<b>COMM PROT SEL</b> Selects the communication protocol. 0 = NOT SEL – No communication protocol selected. 1 = STD MODBUS – The drive communicates with Modbus via the RS485 channel (X1-communications, terminal). <ul style="list-style-type: none"><li>• See also parameter Group 53 EFB PROTOCOL.</li></ul> 4 = EXT FBA – The drive communicates via a fieldbus adapter module in option slot 2 of the drive. <ul style="list-style-type: none"><li>• See also parameter Group 51 EXT COMM MODULE.</li></ul>

# Embedded Fieldbus

---

## Overview

The ACS550 can be set up to accept control from an external system using standard serial communication protocols. When using serial communication, the ACS550 can either:

- Receive all of its control information from the fieldbus, or
- Be controlled from some combination of fieldbus control and other available control locations, such as digital or analog inputs, and the control panel.

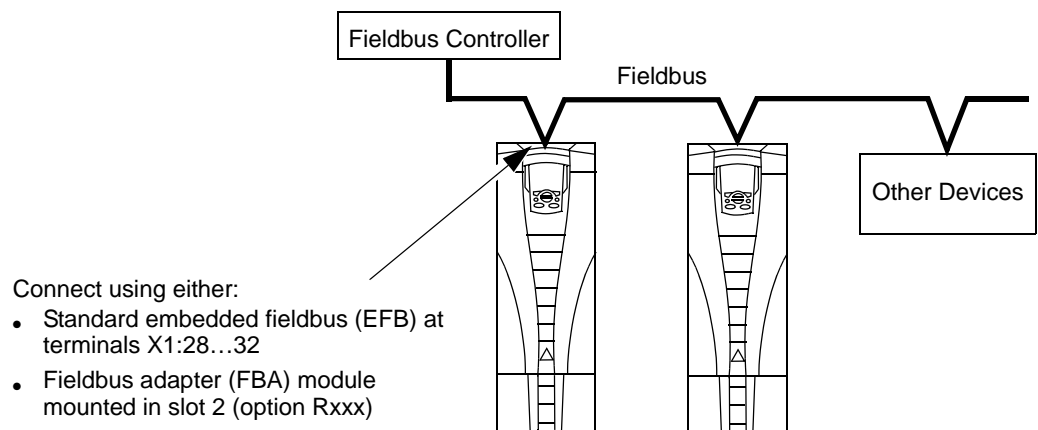

Two basic serial communications configurations are available:

- Embedded fieldbus (EFB) – Using the RS485 interface at terminals X1:28...32 on the control board, a control system can communicate with the drive using the Modbus® protocol. (For protocol and profile descriptions, see "Modbus Protocol Technical Data" and "ABB Control Profiles Technical Data" later in this section.)
- Fieldbus adapter (FBA) – See "Fieldbus Adapter" on page 181.

## Control Interface

In general, the basic control interface between Modbus and the drive consists of:

- Output words
  - Control Word
  - Reference1
  - Reference2
- Input words
  - Status Word
  - Actual value 1
  - Actual value 2
  - Actual value 3

- Actual value 4
- Actual value 5
- Actual value 6
- Actual value 7
- Actual value 8

The content of these words is defined by profiles. For details on the profiles used, see "ABB Control Profiles Technical Data" on page 169.

---

**Note!** The words “output” and “input” are used as seen from the fieldbus controller point of view. For example an output describes data flow from the fieldbus controller to the drive and appears as an input from the drive point of view.

---

## Planning

Network planning should address the following questions:

- What types and quantities of devices must be connected to the network?
- What control information must be sent down to the drives?
- What feedback information must be sent from the drives to the controlling system?

## Mechanical and Electrical Installation – EFB

---



**Warning! Connections should be made only while the drive is disconnected from the power source.**

---

Drive terminals 28...32 are for RS485 communications.

- Use Belden 9842 or equivalent. Belden 9842 is a dual twisted, shielded pair cable with a wave impedance of 120  $\Omega$ .
- Use one of these twisted shielded pairs for the RS485 link. Use this pair to connect all A (-) terminals together and all B (+) terminals together.
- Use one of the wires in the other pair for the logical ground (terminal 31), leaving one wire unused.
- Do not directly ground the RS485 network at any point. Ground all devices on the network using their corresponding earthing terminals.
- As always, the grounding wires should not form any closed loops, and all the devices should be earthed to a common ground.
- Connect the RS485 link in a daisy-chained bus, without dropout lines.

- To reduce noise on the network, terminate the RS485 network using 120 Ω resistors at both ends of the network. Use the DIP switch to connect or disconnect the termination resistors. See following diagram and table.



X1	Identification	Hardware Description	
28	Screen	<div style="display: flex; justify-content: space-between;"> <div style="width: 45%;"> <p>RS485 Multidrop application</p> </div> <div style="width: 45%;"> <p><b>RS485 interface</b></p> </div> </div>	
29	B (Positive +)		
30	A (Negative -)		
31	AGND		
32	Screen		

- Connect the shield at each end of the cable to a drive. On one end, connect the shield to terminal 28, and on the other end connect to terminal 32. Do not connect the incoming and outgoing cable shields to the same terminals, as that would make the shielding continuous.
- For configuration information see the following:
  - "Communication Set-up – EFB" below.
  - "Activate Drive Control Functions – EFB" on page 153.
  - The appropriate EFB protocol specific technical data. For example, "Modbus Protocol Technical Data" on page 161.

## Communication Set-up – EFB

### Serial Communication Selection

To activate the serial communication, set parameter 9802 COMM PROTOCOL SEL = 1 (STD MODBUS).

---

**Note!** If you cannot see the desired selection on the panel, your drive does not have that protocol software in the application memory.

---

## Serial Communication Configuration

Setting 9802 automatically sets the appropriate default values in parameters that define the communication process. These parameters and descriptions are defined below. In particular, note that the station Id may require adjustment.

Code	Description	Protocol Reference
		Modbus
5301	EFB PROTOCOL ID Contains the identification and program revision of the protocol.	Do not edit. Any non-zero value entered for parameter 9802 COMM PROT SEL, sets this parameter automatically. The format is: XYY, where xx = protocol ID, and YY = program revision.
5302	EFB STATION ID Defines the node address of the RS485 link.  <b>Note!</b> For a new address to take affect, the drive power must be cycled <b>or</b> 5302 must first be set to 0 before selecting a new address. Leaving 5302 = 0 places the RS485 channel in reset, disabling communication.	Set each drive on the network with a unique value for this parameter. When this protocol is selected, the default value for this parameter is: 1
5303	EFB BAUD RATE Defines the communication speed of the RS485 link in kbits per second (kbits/s).  1.2 kbits/s                      19.2 kbits/s 2.4 kbits/s                      38.4 kbits/s 4.8 kbits/s                      57.6 kbits/s 9.6 kbits/s                      76.8 kbits/s	When this protocol is selected, the default value for this parameter is: 9.6
5304	EFB PARITY Defines the data length, parity and stop bits to be used with the RS485 communication. <ul style="list-style-type: none"> <li>The same settings must be used in all on-line stations.</li> </ul> 0 = 8N1 – 8 data bits, No parity, one stop bit. 1 = 8N2 – 8 data bits, No parity, two stop bits. 2 = 8E1 – 8 data bits, Even parity, one stop bit. 3 = 8O1 – 8 data bits, Odd parity, one stop bit.	When this protocol is selected, the default value for this parameter is: 1
5305	EFB CTRL PROFILE Selects the communication profile used by the EFB protocol. 0 = ABB DRV LIM – Operation of Control/Status Words conforms to ABB Drives Profile, as used in ACS400. 1 = DCU PROFILE – Operation of Control/Status Words conforms to 32-bit DCU Profile. 2 = ABB DRV FULL – Operation of Control/Status Words conforms to ABB Drives Profile, as used in ACS600/800.	When this protocol is selected, the default value for this parameter is: 0

**Note!** After any changes to the communication settings, the protocol must be reactivated by either cycling the drive power, or by clearing and then restoring the station Id (5302).



## Activate Drive Control Functions – EFB

### Controlling the Drive

Fieldbus control of various drive functions requires configuration to:

- Tell the drive to accept fieldbus control of the function.
- Define as a fieldbus input, any drive data required for control.
- Define as a fieldbus output, any control data required by the drive.

The following sections describe, at a general level, the configuration required for each control function. For the protocol-specific details, see the document supplied with the FBA module.

### Start/Stop Direction Control

Using the fieldbus for start/stop/direction control of the drive requires:

- Drive parameter values set as defined below.
- Fieldbus controller supplied command(s) in the appropriate location. (The location is defined by the Protocol Reference, which is protocol dependent.)

Drive Parameter		Value	Description	Modbus <sup>1</sup> Protocol Reference	
				ABB DRV	DCU PROFILE
1001	EXT1 COMMANDS	10 (COMM)	Start/Stop by fieldbus with Ext1 selected.	40001 bits 0...3	40031 bits 0, 1
1002	EXT2 COMMANDS	10 (COMM)	Start/Stop by fieldbus with Ext2 selected.	40001 bits 0...3	40031 bits 0, 1
1003	DIRECTION	3 (REQUEST)	Direction by fieldbus.	4002/4003 <sup>2</sup>	40031 bit 3

1. For Modbus, the protocol reference can depend on the profile used, hence two columns in these tables. One column refers to the ABB Drives profile, selected when parameter 5305 = 0 (ABB DRV LIM) or 5305 = 2 (ABB DRV FULL). The other column refers to the DCU profile selected when parameter 5305 = 1 (DCU PROFILE). See "ABB Control Profiles Technical Data" on page 169.
2. The reference provides direction control – a negative reference provides reverse rotation.

## Input Reference Select

Using the fieldbus to provide input references to the drive requires:

- Drive parameter values set as defined below.
- Fieldbus controller supplied reference word(s) in the appropriate location. (The location is defined by the Protocol Reference, which is protocol dependent.)

Drive Parameter		Value	Description	Modbus Protocol Reference	
				ABB DRV	DCU PROFILE
1102	EXT1/EXT2 SEL	8 (COMM)	Reference set selection by fieldbus.	40001 bit 11	40031 bit 5
1103	REF1 SEL	8 (COMM)	Input reference 1 by fieldbus.	40002	
1106	REF2 SEL	8 (COMM)	Input reference 2 by fieldbus.	40003	

### Reference Scaling

Where required, REFERENCES can be scaled. See the following, as appropriate:

- Modbus Register "40002" in the "Modbus Protocol Technical Data" section.
- "Reference Scaling" in the "ABB Control Profiles Technical Data" section.

## Miscellaneous Drive Control

Using the fieldbus for miscellaneous drive control requires:

- Drive parameter values set as defined below.
- Fieldbus controller supplied command(s) in the appropriate location. (The location is defined by the Protocol Reference, which is protocol dependent.)

Drive Parameter		Value	Description	Modbus Protocol Reference	
				ABB DRV	DCU PROFILE
1601	RUN ENABLE	7 (COMM)	Run enable by fieldbus.	40001 bit 3	40031 bit 6 (inverted)
1604	FAULT RESET SEL	8 (COMM)	Fault reset by fieldbus.	40001 bit 7	40031 bit 4
1606	LOCAL LOCK	8 (COMM)	Source for local lock selection is the fieldbus.	Does not apply	40031 bit 14
1607	PARAM SAVE	1 (SAVE)	Saves altered parameters to memory (then value returns to 0).	41607	
1608	START ENABLE 1	7 (COMM)	Source for start enable 1 is the fieldbus Command word.	Does not apply.	40032 bit 2
1609	START ENABLE 2	7 (COMM)	Source for start enable 2 is the fieldbus Command word.		40032 bit 3
2013	MIN TORQUE SEL	7 (COMM)	Source for minimum torque selection is the fieldbus.		40031 bit 15
2014	MAX TORQUE SEL	7 (COMM)	Source for maximum torque selection is the fieldbus.		
2201	ACC/DEC 1/2 SEL	7 (COMM)	Source for ramp pair selection is the fieldbus.		40031 bit 10

## Relay Output Control

Using the fieldbus for relay output control requires:

- Drive parameter values set as defined below.
- Fieldbus controller supplied, binary coded, relay command(s) in the appropriate location. (The location is defined by the Protocol Reference, which is protocol dependent.)

Drive Parameter		Value	Description	Modbus Protocol Reference	
				ABB DRV	DCU PROFILE
1401	RELAY OUTPUT 1	35 (COMM)	Relay Output 1 controlled by fieldbus.	40134 bit 0 or 00033	
1402	RELAY OUTPUT 2	35 (COMM)	Relay Output 2 controlled by fieldbus.	40134 bit 1 or 00034	
1403	RELAY OUTPUT 3	35 (COMM)	Relay Output 3 controlled by fieldbus.	40134 bit 2 or 00035	
1410 (Note 1)	RELAY OUTPUT 4	35 (COMM)	Relay Output 4 controlled by fieldbus.	40134 bit 3 or 00036	
1411 (Note 1)	RELAY OUTPUT 5	35 (COMM)	Relay Output 5 controlled by fieldbus.	40134 bit 4 or 00037	
1412 (Note 1)	RELAY OUTPUT 6	35 (COMM)	Relay Output 6 controlled by fieldbus.	40134 bit 5 or 00038	

1. More than 3 relays requires the addition of a relay extension module.

**Note!** Relay status feedback occurs without configuration as defined below.

Drive Parameter		Description	Modbus Protocol Reference	
			ABB DRV	DCU PROFILE
0122	RO 1-3 STATUS	Relay 1...3 status.	40122	
0123	RO 4-6 STATUS	Relay 4...6 status.	40123	

## Analog Output Control

Using the fieldbus for analog output control (e.g. PID setpoint) requires:

- Drive parameter values set as defined below.
- Fieldbus controller supplied analog value(s) in the appropriate location. (The location is defined by the Protocol Reference, which is protocol dependent.)

Drive Parameter		Value	Description	Modbus Protocol Reference	
				ABB DRV	DCU PROFILE
1501	AO1 CONTENT SEL	135 (COMM VALUE 1)	Analog Output 1 controlled by writing to parameter 0135.	-	
0135	COMM VALUE 1	-		40135	
1507	AO2 CONTENT SEL	136 (COMM VALUE 2)	Analog Output 2 controlled by writing to parameter 0136.	-	
0136	COMM VALUE 2	-		40136	

### PID Control Setpoint Source

Using the following settings to select the fieldbus as the setpoint source for PID loops:

Drive Parameter		Value	Description	Modbus Protocol Reference	
				ABB DRV	DCU PROFILE
4010	SET POINT SEL (Set 1)	8 (COMM VALUE 1) 9 (COMM + AI1) 10 (COMM*AI1)	Setpoint is input reference 2 (+/-/* AI1)	40003	
4110	SET POINT SEL (Set 2)				
4210	SET POINT SEL (Ext/Trim)				

### Communication Fault

When using fieldbus control, specify the drive's action if serial communication is lost.

Drive Parameter		Value	Description
3018	COMM FAULT FUNC	0 (NOT SEL) 1 (FAULT) 2 (CONST SP7) 3 (LAST SPEED)	Set for appropriate drive response.
3019	COMM FAULT TIME	Set time delay before acting on a communication loss.	

## Feedback from the Drive – EFB

### Pre-defined Feedback

Inputs to the controller (drive outputs) have pre-defined meanings established by the protocol. This feedback does not require drive configuration. The following table lists a sample of feedback data. For a complete listing, see input word/point/object listings in the technical data for the appropriate protocol starting on page 161.

Drive Parameter		Modbus Protocol Reference	
		ABB DRV	DCU PROFILE
0102	SPEED		40102
0103	FREQ OUTPUT		40103
0104	CURRENT		40104
0105	TORQUE		40105
0106	POWER		40106
0107	DC BUS VOLT		40107
0109	OUTPUT VOLTAGE		40109
0301	FB STATUS WORD – bit 0 (STOP)		40301 bit 0
0301	FB STATUS WORD – bit 2 (REV)		40301 bit 2
0118	DI1-3 STATUS – bit 1 (DI3)		40118

**Note!** With Modbus, any parameter can be accessed using the format: “4” followed by the parameter number.

### Actual Value Scaling

The scaling of actual values can be protocol dependent. In general, for Actual Values, scale the feedback integer using the parameter's resolution. (See "Complete Parameter List for ACS550" section for parameter resolutions.) For example:

Feedback Integer	Parameter Resolution	(Feedback Integer) * (Parameter Resolution) = Scaled Value
1	0.1 mA	1 * 0.1 mA = 0.1 mA
10	0.1%	10 * 0.1% = 1%

Where parameters are in percent, the "Complete Parameter Descriptions" section specifies what parameter corresponds to 100%. In such cases, to convert from percent to engineering units, multiply by the value of the parameter that defines 100% and divide by 100%.

For example:

Feedback Integer	Parameter Resolution	Value of the Parameter that defines 100%	(Feedback Integer) * (Parameter Resolution) * (Value of 100% Ref.) / 100% = Scaled Value
10	0.1%	1500 rpm (Note 1)	$10 * 0.1\% * 1500 \text{ RPM} / 100\% = 15 \text{ rpm}$
100	0.1%	500 Hz (Note 2)	$100 * 0.1\% * 500 \text{ Hz} / 100\% = 50 \text{ Hz}$

1. Assuming, for the sake of this example, that the Actual Value uses parameter 9908 MOT NOM SPEED as the 100% reference, and that 9908 = 1500 rpm.
2. Assuming, for the sake of this example, that the Actual Value uses parameter 9907 MOT NOM FREQ as the 100% reference, and that 9907 = 500 Hz.

## Diagnostics – EFB

### Fault Queue for Drive Diagnostics

For general ACS550 diagnostics information, see "Diagnostics" starting on page 201. The three most recent ACS550 faults are reported to the fieldbus as defined below.

Drive Parameter		Modbus Protocol Reference	
		ABB DRV	DCU PROFILE
0401	Last Fault	40401	
0412	Previous Fault 1	40402	
0413	Previous Fault 2	40403	

### Serial Communication Diagnostics

Network problems can be caused by multiple sources. Some of these sources are:

- Loose connections
- Incorrect wiring (including swapped wires)
- Bad grounding
- Duplicate station numbers
- Incorrect setup of drives or other devices on the network

The major diagnostic features for fault tracing on an EFB network include Group 53 EFB Protocol parameters 5306...5309. The "Complete Parameter Descriptions" section describes these parameters in detail.

## Diagnostic Situations

The sub-sections below describe various diagnostic situations – the problem symptoms and corrective actions.

### *Normal Operation*

During normal network operation, 5306...5309 parameter values act as follows at each drive:

- 5306 EFB OK MESSAGES advances (advances for each message properly received and addressed to this drive).
- 5307 EFB CRC ERRORS does not advance at all (advances when an invalid message CRC is received).
- 5308 EFB UART ERRORS does not advance at all (advances when character format errors are detected, such as parity or framing errors).
- 5309 EFB status value varies depending on network traffic.

### *Loss of Communication*

The ACS550 behavior, if communication is lost, was configured earlier in "Communication Fault". The parameters are 3018 COMM FAULT FUNC and 3019 COMM FAULT TIME. The "Complete Parameter Descriptions" section describes these parameters in detail.

### *No Master Station on Line*

If no master station is on line: Neither the EFB OK MESSAGES nor the errors (5307 EFB CRC ERRORS and 5308 EFB UART ERRORS) increase on any of the stations.

To correct:

- Check that a network master is connected and properly programmed on the network.
- Verify that the cable is connected, and is not cut or short circuited.

### *Duplicate Stations*

If two or more stations have duplicate numbers:

- Two or more drives cannot be addressed.
- Every time there is a read or write to one particular station, the value for 5307 EFB CRC ERRORS or 5308 EFB UART ERRORS advances.

To correct: Verify the station numbers of all stations. Change conflicting station numbers.

### *Swapped Wires*

If the communication wires are swapped (terminal A on one drive is connected to terminal B on another):

- The value of 5306 EFB OK MESSAGES does not advance.
- The values of 5307 EFB CRC ERRORS and 5308 EFB UART ERRORS are advancing.

To correct: Check that the RS-485 lines are not swapped.

### *Fault 28 – Serial 1 Err*

If the drive's control panel shows fault code 28 "SERIAL 1 ERR", check for either of the following:

- The master system is down. To correct, resolve problem with master system.
- The communication connection is bad. To correct, check communication connection at the drive.
- The time-out selection for the drive is too short for the given installation. The master is not polling the drive within the specified time-out delay. To correct, increase the time set by parameter 3019 COMM FAULT TIME.

### *Faults 31...33 – EFB1...EFB3*

The three EFB fault codes listed for the drive in "Diagnostics" starting on page 201 (fault codes 31...33) are not used.

### *Intermittent Off-line Occurrences*

The problems described above are the most common problems encountered with ACS550 serial communication. Intermittent problems might also be caused by:

- Marginally loose connections,
- Wear on wires caused by equipment vibrations,
- Insufficient grounding and shielding on both the devices and on the communication cables.



## Modbus Protocol Technical Data

### Overview

The Modbus® protocol was introduced by Modicon, Inc. for use in control environments featuring Modicon programmable controllers. Due to its ease of use and implementation, this common PLC language was quickly adopted as a de-facto standard for integration of a wide variety of master controllers and slave devices.

Modbus is a serial, asynchronous protocol. Transactions are half-duplex, featuring a single Master controlling one or more Slaves. While RS232 can be used for point-to-point communication between a single Master and a single Slave, a more common implementation features a multi-drop RS485 network with a single Master controlling multiple Slaves. The ACS550 features RS485 for its Modbus physical interface.

### RTU

The Modbus specification defines two distinct transmission modes: ASCII and RTU. The ACS550 supports RTU only.

### Feature Summary

The following Modbus function codes are supported by the ACS550.

Function	Code (Hex)	Description
Read Coil Status	0x01	Read discrete output status. For the ACS550, the individual bits of the control word are mapped to Coils 1...16. Relay outputs are mapped sequentially beginning with Coil 33 (e.g. RO1=Coil 33).
Read Discrete Input Status	0x02	Read discrete inputs status. For the ACS550, the individual bits of the status word are mapped to Inputs 1...16 or 1...32, depending on the active profile. Terminal inputs are mapped sequentially beginning with Input 33 (e.g. DI1=Input 33).
Read Multiple Holding Registers	0x03	Read multiple holding registers. For the ACS550, the entire parameter set is mapped as holding registers, as well as command, status and reference values.
Read Multiple Input Registers	0x04	Read multiple input registers. For the ACS550, the 2 analog input channels are mapped as input registers 1 & 2.
Force Single Coil	0x05	Write a single discrete output. For the ACS550, the individual bits of the control word are mapped to Coils 1...16. Relay outputs are mapped sequentially beginning with Coil 33 (e.g. RO1=Coil 33).
Write Single Holding Register	0x06	Write single holding register. For the ACS550, the entire parameter set is mapped as holding registers, as well as command, status and reference values.
Diagnostics	0x08	Perform Modbus diagnostics. Subcodes for Query (0x00), Restart (0x01) & Listen Only (0x04) are supported.
Force Multiple Coils	0x0F	Write multiple discrete outputs. For the ACS550, the individual bits of the control word are mapped to Coils 1...16. Relay outputs are mapped sequentially beginning with Coil 33 (e.g. RO1=Coil 33).
Write Multiple Holding Registers	0x10	Write multiple holding registers. For the ACS550, the entire parameter set is mapped as holding registers, as well as command, status and reference values.
Read/Write Multiple Holding Registers	0x17	This function combines functions 0x03 and 0x10 into a single command.

### Mapping Summary

The following table summarizes the mapping between the ACS550 (parameters and I/O) and Modbus reference space. For details, see "Modbus Addressing" below.

ACS550	Modbus Reference	Supported Function Codes
<ul style="list-style-type: none"> <li>Control Bits</li> <li>Relay Outputs</li> </ul>	Coils(0xxxx)	<ul style="list-style-type: none"> <li>01 – Read Coil Status</li> <li>05 – Force Single Coil</li> <li>15 – Force Multiple Coils</li> </ul>
<ul style="list-style-type: none"> <li>Status Bits</li> <li>Discrete Inputs</li> </ul>	Discrete Inputs(1xxxx)	<ul style="list-style-type: none"> <li>02 – Read Input Status</li> </ul>
<ul style="list-style-type: none"> <li>Analog Inputs</li> </ul>	Input Registers(3xxxxx)	<ul style="list-style-type: none"> <li>04 – Read Input Registers</li> </ul>
<ul style="list-style-type: none"> <li>Parameters</li> <li>Control/Status Words</li> <li>References</li> </ul>	Holding Registers(4xxxx)	<ul style="list-style-type: none"> <li>03 – Read 4X Registers</li> <li>06 – Preset Single 4X Register</li> <li>16 – Preset Multiple 4X Registers</li> <li>23 – Read/Write 4X Registers</li> </ul>

### Communication Profiles

When communicating by Modbus, the ACS550 supports multiple profiles for control and status information. Parameter 5305 (EFB CTRL PROFILE) selects the profile used.

- ABB DRV LIM – The primary (and default) profile is the ABB DRV LIM profile. This implementation of the ABB Drives profile standardizes the control interface with ACS400 drives. The ABB Drives profile is based on the PROFIBUS interface, and is discussed in detail in the following sections.
- DCU PROFILE – The DCU PROFILE profile extends the control and status interface to 32 bits, and is the internal interface between the main drive application and the embedded fieldbus environment.
- ABB DRV FULL – ABB DRV FULL is the implementation of the ABB Drives profile that standardizes the control interface with ACS600 and ACS800 drives. This implementation supports two control word bits not supported by the ABB DRV LIM implementation.

### Modbus Addressing

With Modbus, each function code implies access to a specific Modbus reference set. Thus, the leading digit is not included in the address field of a Modbus message.

---

**Note:** The ACS550 supports the zero-based addressing of the Modbus specification. Holding register 40002 is addressed as 0001 in a Modbus message. Similarly, coil 33 is addressed as 0032 in a Modbus message.

---

Refer again to the "Mapping Summary" above. The following sections describe, in detail, the mapping to each Modbus reference set.

**0xxxx Mapping – Modbus Coils.** The drive maps the following information to the 0xxxx Modbus set called Modbus Coils:

- Bit-wise map of the CONTROL WORD (selected using parameter 5305 EFB CTRL PROFILE). The first 32 coils are reserved for this purpose.

- Relay output states, numbered sequentially beginning with coil 00033.

The following table summarizes the 0xxxx reference set:

Modbus Ref.	Internal Location (All Profiles)	ABB DRV LIM (5305 = 0)	DCU PROFILE (5305 = 1)	ABB DRV FULL (5305 = 2)
00001	CONTROL WORD – Bit 0	OFF1*	STOP	OFF1*
00002	CONTROL WORD – Bit 1	OFF2*	START	OFF2*
00003	CONTROL WORD – Bit 2	OFF3*	REVERSE	OFF3*
00004	CONTROL WORD – Bit 3	START	LOCAL	START
00005	CONTROL WORD – Bit 4	N/A	RESET	RAMP_OUT_ZERO*
00006	CONTROL WORD – Bit 5	RAMP_HOLD*	EXT2	RAMP_HOLD*
00007	CONTROL WORD – Bit 6	RAMP_IN_ZERO*	RUN_DISABLE	RAMP_IN_ZERO*
00008	CONTROL WORD – Bit 7	RESET	STPMODE_R	RESET
00009	CONTROL WORD – Bit 8	N/A	STPMODE_EM	N/A
00010	CONTROL WORD – Bit 9	N/A	STPMODE_C	N/A
00011	CONTROL WORD – Bit 10	N/A	RAMP_2	REMOTE_CMD*
00012	CONTROL WORD – Bit 11	EXT2	RAMP_OUT_0	EXT2
00013	CONTROL WORD – Bit 12	N/A	RAMP_HOLD	N/A
00014	CONTROL WORD – Bit 13	N/A	RAMP_IN_0	N/A
00015	CONTROL WORD – Bit 14	N/A	REQ_LOCALLOCK	N/A
00016	CONTROL WORD – Bit 15	N/A	TORQLIM2	N/A
00017	CONTROL WORD – Bit 16	Does not apply	FBLOCAL_CTL	Does not apply
00018	CONTROL WORD – Bit 17		FBLOCAL_REF	
00019	CONTROL WORD – Bit 18		START_DISABLE1	
00020	CONTROL WORD – Bit 19		START_DISABLE2	
00021... 00032	Reserved	Reserved	Reserved	Reserved
00033	RELAY OUTPUT 1	Relay Output 1	Relay Output 1	Relay Output 1
00034	RELAY OUTPUT 2	Relay Output 2	Relay Output 2	Relay Output 2
00035	RELAY OUTPUT 3	Relay Output 3	Relay Output 3	Relay Output 3
00036	RELAY OUTPUT 4	Relay Output 4	Relay Output 4	Relay Output 4
00037	RELAY OUTPUT 5	Relay Output 5	Relay Output 5	Relay Output 5
00038	RELAY OUTPUT 6	Relay Output 6	Relay Output 6	Relay Output 6

\* = Active low

For the 0xxxx registers:

- Status is always readable.
- Forcing is allowed by user configuration of the drive for fieldbus control.
- Additional relay outputs are added sequentially.

The ACS550 supports the following Modbus function codes for coils:

Function Code	Description
01	Read coil status
05	Force single coil
15 (0x0F Hex)	Force multiple coils

**1xxxx Mapping – Modbus Discrete Inputs.** The drive maps the following information to the 1xxxx Modbus set called Modbus Discrete Inputs:

- Bit-wise map of the STATUS WORD (selected using parameter 5305 EFB CTRL PROFILE). The first 32 inputs are reserved for this purpose.
- Discrete hardware inputs, numbered sequentially beginning with input 33.

The following table summarizes the 1xxxx reference set:

Modbus Ref.	Internal Location (All Profiles)	ABB DRV (5305 = 0 OR 2)	DCU PROFILE (5305 = 1)
10001	STATUS WORD – Bit 0	RDY_ON	READY
10002	STATUS WORD – Bit 1	RDY_RUN	ENABLED
10003	STATUS WORD – Bit 2	RDY_REF	STARTED
10004	STATUS WORD – Bit 3	TRIPPED	RUNNING
10005	STATUS WORD – Bit 4	OFF_2_STA*	ZERO_SPEED
10006	STATUS WORD – Bit 5	OFF_3_STA*	ACCELERATE
10007	STATUS WORD – Bit 6	SWC_ON_INHIB	DECELERATE
10008	STATUS WORD – Bit 7	ALARM	AT_SETPOINT
10009	STATUS WORD – Bit 8	AT_SETPOINT	LIMIT
10010	STATUS WORD – Bit 9	REMOTE	SUPERVISION
10011	STATUS WORD – Bit 10	ABOVE_LIMIT	REV_REF
10012	STATUS WORD – Bit 11	EXT2	REV_ACT
10013	STATUS WORD – Bit 12	RUN_ENABLE	PANEL_LOCAL
10014	STATUS WORD – Bit 13	N/A	FIELDBUS_LOCAL
10015	STATUS WORD – Bit 14	N/A	EXT2_ACT
10016	STATUS WORD – Bit 15	N/A	FAULT
10017	STATUS WORD – Bit 16	Reserved	ALARM
10018	STATUS WORD – Bit 17	Reserved	REQ_MAINT
10019	STATUS WORD – Bit 18	Reserved	DIRLOCK
10020	STATUS WORD – Bit 19	Reserved	LOCALLOCK
10021	STATUS WORD – Bit 20	Reserved	CTL_MODE
10022	STATUS WORD – Bit 21	Reserved	Reserved
10023	STATUS WORD – Bit 22	Reserved	Reserved
10024	STATUS WORD – Bit 23	Reserved	Reserved
10025	STATUS WORD – Bit 24	Reserved	Reserved
10026	STATUS WORD – Bit 25	Reserved	Reserved
10027	STATUS WORD – Bit 26	Reserved	REQ_CTL

Modbus Ref.	Internal Location (All Profiles)	ABB DRV (5305 = 0 OR 2)	DCU PROFILE (5305 = 1)
10028	STATUS WORD – Bit 27	Reserved	REQ_REF1
10029	STATUS WORD – Bit 28	Reserved	REQ_REF2
10030	STATUS WORD – Bit 29	Reserved	REQ_REF2EXT
10031	STATUS WORD – Bit 30	Reserved	ACK_STARTINH
10032	STATUS WORD – Bit 31	Reserved	ACK_OFF_ILCK
10033	DI1	DI1	DI1
10034	DI2	DI2	DI2
10035	DI3	DI3	DI3
10036	DI4	DI4	DI4
10037	DI5	DI5	DI5
10038	DI6	DI6	DI6

\* = Active low

For the 1xxxx registers:

- Additional discrete inputs are added sequentially.

The ACS550 supports the following Modbus function codes for discrete inputs:

Function Code	Description
02	Read input status

**3xxxx Mapping – Modbus Inputs.** The drive maps the following information to the 3xxxx Modbus addresses called Modbus input registers:

- Any user defined analog inputs.

The following table summarizes the input registers:

Modbus Reference	ACS550 All Profiles	Remarks
30001	AI1	This register shall report the level of Analog Input 1 (0...100%).
30002	AI2	This register shall report the level of Analog Input 2 (0...100%).

The ACS550 supports the following Modbus function codes for 3xxxx registers:

Function Code	Description
04	Read 3xxxx input status

**4xxxx Register Mapping.** The drive maps its parameters and other data to the 4xxxx holding registers as follows:

- 40001...40099 map to drive control and actual values. These registers are described in the table below.
- 40101...49999 map to drive parameters 0101...9999. Register addresses that do not correspond to drive parameters are invalid. If there is an attempt to read or write outside the parameter addresses, the Modbus interface returns an exception code to the controller.

The following table summarizes the 4xxxx drive control registers 40001...40099 (for 4xxxx registers above 40099, see the drive parameter list, e.g. 40102 is parameter 0102):

Modbus Register		Access	Remarks
40001	CONTROL WORD	R/W	Maps directly to the profile's CONTROL WORD. Supported only if 5305 = 0 or 2 (ABB Drives profile). Parameter 5319 holds a copy in hex format.
40002	Reference 1	R/W	Range = 0...+20000 (scaled to 0...1105 REF1 MAX), or -20000...0 (scaled to 1105 REF1 MAX...0).
40003	Reference 2	R/W	Range = 0...+10000 (scaled to 0...1108 REF2 MAX), or -10000...0 (scaled to 1108 REF2 MAX...0).
40004	STATUS WORD	R	Maps directly to the profile's STATUS WORD. Supported only if 5305 = 0 or 2 (ABB Drives profile). Parameter 5320 holds a copy in hex format.
40005	Actual 1 (select using 5310)	R	By default, stores a copy of 0103 OUTPUT FREQ. Use parameter 5310 to select a different actual value for this register.
40006	Actual 2 (select using 5311)	R	By default, stores a copy of 0104 CURRENT. Use parameter 5311 to select a different actual value for this register.
40007	Actual 3 (select using 5312)	R	By default, stores nothing. Use parameter 5312 to select an actual value for this register.
40008	Actual 4 (select by 5313)	R	By default, stores nothing. Use parameter 5313 to select an actual value for this register.
40009	Actual 5 (select using 5314)	R	By default, stores nothing. Use parameter 5314 to select an actual value for this register.
40010	Actual 6 (select using 5315)	R	By default, stores nothing. Use parameter 5315 to select an actual value for this register.
40011	Actual 7 (select using 5316)	R	By default, stores nothing. Use parameter 5316 to select an actual value for this register.
40012	Actual 8 (select using 5317)	R	By default, stores nothing. Use parameter 5317 to select an actual value for this register.
40031	ACS550 CONTROL WORD LSW	R/W	Maps directly to the Least Significant Word of the DCU profile's CONTROL WORD. Supported only if 5305 = 1. See parameter 0301.
40032	ACS550 CONTROL WORD MSW	R	Maps directly to the Most Significant Word of the DCU profile's CONTROL WORD. Supported only if 5305 = 1. See parameter 0302.
40033	ACS550 STATUS WORD LSW	R	Maps directly to the Least Significant Word of the DCU profile's STATUS WORD. Supported only if 5305 = 1. See parameter 0303.
40034	ACS550 STATUS WORD MSW	R	Maps directly to the Most Significant Word of the DCU profile's STATUS WORD. Supported only if 5305 = 1. See parameter 0304.

For the Modbus protocol, drive parameters in group 53 report the parameter mapping to 4xxxx Registers.

Code	Description
5310	EFB PAR 10 Specifies the parameter mapped to Modbus register 40005.
5311	EFB PAR 11 Specifies the parameter mapped to Modbus register 40006.
5312	EFB PAR 12 Specifies the parameter mapped to Modbus register 40007.
5313	EFB PAR 13 Specifies the parameter mapped to Modbus register 40008.
5314	EFB PAR 14 Specifies the parameter mapped to Modbus register 40009.
5315	EFB PAR 15 Specifies the parameter mapped to Modbus register 40010.
5316	EFB PAR 16 Specifies the parameter mapped to Modbus register 40011.
5317	EFB PAR 17 Specifies the parameter mapped to Modbus register 40012.
5319	EFB PAR 19 Holds a copy (in hex) of the CONTROL WORD, Modbus register 40001.
5320	EFB PAR 20 Holds a copy (in hex) of the STATUS WORD, Modbus register 40004.

Except where restricted by the drive, all parameters are available for both reading and writing. The parameter writes are verified for the correct value, and for a valid register addresses.

---

**Note!** Parameter writes through standard Modbus are always volatile i.e. modified values are not automatically stored to permanent memory. Use parameter 1607 PARAM. SAVE to save all altered values.

---

The ACS550 supports the following Modbus function codes for 4xxxx registers:

Function Code	Description
03	Read holding 4xxxx registers
06	Preset single 4xxxx register
16 (0x10 Hex)	Preset multiple 4xxxx registers
23 (0x17 Hex)	Read/write 4xxxx registers

### Actual Values

The contents of the register addresses 40005...40012 are ACTUAL VALUES and are:

- Specified using parameters 5310...5317.
- Read-only values containing information on the operation of the drive.
- 16-bit words containing a sign bit and a 15-bit integer.
- When negative values, written as the two's complement of the corresponding positive value.
- Scaled as described earlier in "Actual Value Scaling".

### Exception Codes

Exception codes are serial communication responses from the drive. The ACS550 supports the standard Modbus exception codes defined below.

Exception Code	Name	Meaning
01	ILLEGAL FUNCTION	Unsupported Command
02	ILLEGAL DATA ADDRESS	The data address received in the query is not allowable. It is not a defined parameter/group.
03	ILLEGAL DATA VALUE	A value contained in the query data field is not an allowable value for the ACS550, because it is one of the following: <ul style="list-style-type: none"> <li>• Outside min. or max. limits.</li> <li>• Parameter is read-only.</li> <li>• Message is too long.</li> <li>• Parameter write not allowed when start is active.</li> <li>• Parameter write not allowed when factory macro is selected.</li> </ul>

For the Modbus protocol, a drive parameter in group 53 holds the most recent exception code:

Code	Description
5318	EFB PAR 18 Holds the most recent exception code.



## ABB Control Profiles Technical Data

### Overview

#### *ABB Drives Profile*

The ABB Drives profile provides a standard profile that can be used on multiple protocols, including Modbus and the protocols available on the FBA module. Two implementations of the ABB Drives profile are available:

- ABB DRV FULL – This implementation standardizes the control interface with ACS600 and ACS800 drives.
- ABB DRV LIM – This implementation standardizes the control interface with ACS400 drives. This implementation does not support two control word bits supported by ABB DRV FULL.

Except as noted, the following “ABB Drives Profile” descriptions apply to both implementations.

#### *DCU Profile*

The DCU profile extends the control and status interface to 32 bits, and is the internal interface between the main drive application and the embedded fieldbus environment.

### Control Word

The CONTROL WORD is the principal means for controlling the drive from a fieldbus system. The fieldbus master station sends the CONTROL WORD to the drive. The drive switches between states according to the bit-coded instructions in the CONTROL WORD. Using the CONTROL WORD requires that:

- The drive is in remote (REM) control.
- The serial communication channel is defined as the source for controlling commands (set using parameters such as 1001 EXT1 COMMANDS, 1002 EXT2 COMMANDS and 1102 EXT1/EXT2 SEL).
- The serial communication channel used is configured to use an ABB control profile. For example, to use the control profile ABB DRV FULL, requires both parameter 9802 COMM PROT SEL = 1 (STD MODBUS), and parameter 5305 EFB CTRL PROFILE = 2 (ABB DRV FULL).

### ABB Drives Profile

The following table and the state diagram later in this sub-section describe the CONTROL WORD content for the ABB Drives profile.

ABB Drives Profile CONTROL WORD (See Parameter 5319)				
Bit	Name	Value	Commanded State	Comments
0	OFF1 CONTROL	1	READY TO OPERATE	Enter READY TO OPERATE
		0	EMERGENCY OFF	Drive ramps to stop according to currently active deceleration ramp (2203 or 2205) Normal command sequence: <ul style="list-style-type: none"> <li>• Enter OFF1 ACTIVE</li> <li>• Proceed to READY TO SWITCH ON, unless other interlocks (OFF2, OFF3) are active.</li> </ul>
1	OFF2 CONTROL	1	OPERATING	Continue operation (OFF2 inactive)
		0	EMERGENCY OFF	Drive coasts to stop. Normal command sequence: <ul style="list-style-type: none"> <li>• Enter OFF2 ACTIVE</li> <li>• Proceed to SWITCHON INHIBITED</li> </ul>
2	OFF3 CONTROL	1	OPERATING	Continue operation (OFF3 inactive)
		0	EMERGENCY STOP	Drive stops within in time specified by parameter 2208. Normal command sequence: <ul style="list-style-type: none"> <li>• Enter OFF3 ACTIVE</li> <li>• Proceed to SWITCH ON INHIBITED</li> </ul> <b>WARNING! Be sure motor and driven equipment can be stopped using this mode.</b>
3	INHIBIT OPERATION	1	OPERATION ENABLED	Enter OPERATION ENABLED (Note the Run enable signal must be active. See 1601. If 1601 is set to COMM, this bit also activates the Run Enable signal.)
		0	OPERATION INHIBITED	Inhibit operation. Enter OPERATION INHIBITED
4	Unused (ABB DRV LIM)			
	RAMP_OUT_ZERO (ABB DRV FULL)	1	NORMAL OPERATION	Enter RAMP FUNCTION GENERATOR: ACCELERATION ENABLED
		0	RFG OUT ZERO	Force ramp function generator output to Zero. Drive ramps to stop (current and DC voltage limits in force).
5	RAMP_HOLD	1	RFG OUT ENABLED	Enable ramp function. Enter RAMP FUNCTION GENERATOR: ACCELERATOR ENABLED
		0	RFG OUT HOLD	Halt ramping (Ramp Function Generator output held)
6	RAMP_IN_ZERO	1	RFG INPUT ENABLED	Normal operation. Enter OPERATING
		0	RFG INPUT ZERO	Force Ramp Function Generator input to zero.

ABB Drives Profile CONTROL WORD (See Parameter 5319)				
Bit	Name	Value	Commanded State	Comments
7	RESET	0=>1	RESET	Fault reset if an active fault exists (Enter SWITCH-ON INHIBITED). Effective if 1604 = COMM.
		0	OPERATING	Continue normal operation
8...9	Unused			
10	Unused (ABB DRV LIM)			
	REMOTE_CMD (ABB DRV FULL)	1		Fieldbus control enabled.
		0		<ul style="list-style-type: none"> <li>CW ≠ 0 or Ref ≠ 0: Retain last CW and Ref.</li> <li>CW = 0 and Ref = 0: Fieldbus control enabled.</li> <li>Ref and deceleration/acceleration ramp are locked.</li> </ul>
11	EXT CTRL LOC	1	EXT2 SELECT	Select external control location 2 (EXT2). Effective if 1102 = COMM.
		0	EXT1 SELECT	Select external control location 1 (EXT1). Effective if 1102 = COMM.
12...15	Unused			

### DCU Profile

The following tables describe the CONTROL WORD content for the DCU profile.

DCU Profile CONTROL WORD (See Parameter 0301)				
Bit	Name	Value	Command/Req.	Comments
0	STOP	1	Stop	Stops according to either the stop mode parameter or the stop mode requests (bits 7 and 8).
		0	(no op)	
1	START	1	Start	Simultaneous STOP and START commands result in a stop command.
		0	(no op)	
2	REVERSE	1	Reverse direction	This bit XOR'd with the sign of the reference defines direction.
		0	Forward direction	
3	LOCAL	1	Local mode	When the fieldbus sets this bit, it steals control and the drive moves to fieldbus local control mode.
		0	External mode	
4	RESET	-> 1	Reset	Edge sensitive.
		other	(no op)	
5	EXT2	1	Switch to EXT2	
		0	Switch to EXT1	
6	RUN_DISABLE	1	Run disable	Inverted run enable.
		0	Run enable on	
7	STPMODE_R	1	Normal ramp stop mode	
		0	(no op)	

DCU Profile CONTROL WORD (See Parameter 0301)				
Bit	Name	Value	Command/Req.	Comments
8	STPMODE_EM	1	Emergency ramp stop mode	
		0	(no op)	
9	STPMODE_C	1	Coast stop mode	
		0	(no op)	
10	RAMP_2	1	Ramp pair 2	
		0	Ramp pair 1	
11	RAMP_OUT_0	1	Ramp output to 0	
		0	(no op)	
12	RAMP_HOLD	1	Ramp freeze	
		0	(no op)	
13	RAMP_IN_0	1	Ramp input to 0	
		0	(no op)	
14	RREQ_LOCALL OC	1	Local mode lock	In lock, drive will not switch to local mode.
		0	(no op)	
15	TORQLIM2	1	Torque limit pair 2	
		0	Torque limit pair 1	

DCU Profile CONTROL WORD (See Parameter 0302)				
Bit	Name	Value	Function	Comments
16...26	Reserved			
27	REF_CONST	1	Constant speed ref.	These bits are only for supervision purposes.
		0	(no op)	
28	REF_AVE	1	Average speed ref.	
		0	(no op)	
29	LINK_ON	1	Master is detected in link	
		0	Link is down	
30	REQ_STARTINH	1	Start inhibit request is pending	
		0	Start inhibit request is OFF	
31	OFF_INTERLOCK	1	Panel OFF button pressed	For the control panel (or PC tool) this is the OFF button interlock.
		0	(no op)	

### Status Word

The contents of the STATUS WORD is status information, sent by the drive to the master station.

### ABB Drives Profile

The following table and the state diagram later in this sub-section describe the STATUS WORD content for the ABB Drives profile.

<b>ABB Drives Profile (EFB) STATUS WORD (See Parameter 5320)</b>			
<b>Bit</b>	<b>Name</b>	<b>Value</b>	<b>Description (Correspond to states/boxes in the state diagram)</b>
0	RDY_ON	1	READY TO SWITCH ON
		0	NOT READY TO SWITCH ON
1	RDY_RUN	1	READY TO OPERATE
		0	OFF1 ACTIVE
2	RDY_REF	1	OPERATION ENABLED
		0	OPERATION INHIBITED
3	TRIPPED	0...1	FAULT
		0	No fault
4	OFF_2_STA	1	OFF2 INACTIVE
		0	<b>OFF2 ACTIVE</b>
5	OFF_3_STA	1	OFF3 INACTIVE
		0	<b>OFF3 ACTIVE</b>
6	SWC_ON_INHIB	1	SWITCH-ON INHIBIT ACTIVE
		0	SWITCH-ON INHIBIT NOT ACTIVE
7	ALARM	1	Warning/alarm (See "Alarm Listing" in the "Diagnostics" section for details on alarms.)
		0	No warning/alarm
8	AT_SETPOINT	1	OPERATING. Actual value equals (within tolerance limits) the reference value.
		0	Actual value is outside tolerance limits (not equal to reference value).
9	REMOTE	1	Drive control location: REMOTE (EXT1 or EXT2)
		0	Drive control location: LOCAL
10	ABOVE_LIMIT	1	Supervised parameter's value $\geq$ supervision high limit. Bit remains "1" until supervised parameter's value < supervision low limit. See group 32, Supervision
		0	Supervised parameter's value < supervision low limit. Bit remains "0" until supervised parameter's value > supervision high limit. See group 32, Supervision
11	EXT CTRL LOC	1	External control location 2 (EXT2) selected
		0	External control location 1 (EXT1) selected
12	EXT RUN ENABLE	1	External Run Enable signal received
		0	No External Run Enable signal received
13... 15	Unused		

*DCU Profile*

The following tables describe the STATUS WORD content for the DCU profile.

<b>DCU Profile STATUS WORD (See Parameter 0303)</b>			
<b>Bit</b>	<b>Name</b>	<b>Value</b>	<b>Status</b>
0	READY	1	Drive is ready to receive start command.
		0	Drive is not ready.
1	ENABLED	1	External run enable signal received.
		0	No external run enable signal received.
2	STARTED	1	Drive has received start command.
		0	Drive has not received start command.
3	RUNNING	1	Drive is modulating.
		0	Drive is not modulating.
4	ZERO_SPEED	1	Drive is at zero speed.
		0	Drive has not reached zero speed.
5	ACCELERATE	1	Drive is accelerating.
		0	Drive is not accelerating.
6	DECELERATE	1	Drive is decelerating.
		0	Drive is not decelerating.
7	AT_SETPOINT	1	Drive is at setpoint.
		0	Drive has not reached setpoint.
8	LIMIT	1	Operation is limited by Group 20 settings.
		0	Operation is within Group 20 settings.
9	SUPERVISION	1	A supervised parameter (Group 32) is outside its limits.
		0	All supervised parameters are within limits.
10	REV_REF	1	Drive reference is in reverse direction.
		0	Drive reference is in forward direction.
11	REV_ACT	1	Drive is running in reverse direction.
		0	Drive is running in forward direction.
12	PANEL_LOCAL	1	Control is in control panel (or PC tool) local mode.
		0	Control is not in control panel local mode.
13	FIELDBUS_LOCAL	1	Control is in fieldbus local mode (steals control panel local).
		0	Control is not in fieldbus local mode.
14	EXT2_ACT	1	Control is in EXT2 mode.
		0	Control is in EXT1 mode.
15	FAULT	1	Drive is in a fault state.
		0	Drive is not in a fault state.

<b>DCU Profile STATUS WORD (See Parameter 0304)</b>			
<b>Bit</b>	<b>Name</b>	<b>Value</b>	<b>Status</b>
16	ALARM	1	An alarm is on.
		0	No alarms are on.
17	REQ_MAINT	1	A maintenance request is pending.
		0	No maintenance request is pending.
18	DIRLOCK	1	Direction lock is ON. (Direction change is locked out.)
		0	Direction lock is OFF.
19	LOCALLOCK	1	Local mode lock is ON. (Local mode is locked out.)
		0	Local mode lock is OFF.
20	CTL_MODE	1	Drive is in vector control mode.
		0	Drive is in scalar control mode.
21...25	Reserved		
26	REQ_CTL	1	Copy the control word
		0	(no op)
27	REQ_REF1	1	Reference 1 requested in this channel.
		0	Reference 1 is not requested in this channel.
28	REQ_REF2	1	Reference 2 requested in this channel.
		0	Reference 2 is not requested in this channel.
29	REQ_REF2EXT	1	External PID reference 2 requested in this channel.
		0	External PID reference 2 is not requested in this channel.
30	ACK_STARTINH	1	A start inhibit from this channel is granted.
		0	A start inhibit from this channel is not granted.
31	ACK_OFF_ILCK	1	Start inhibit due to OFF button
		0	Normal operation

## State Diagram

### ABB Drives Profile

To illustrate the operation of the state diagram, the following example (ABB DRV LIM implementation of the ABB Drives profile) uses the control word to start the drive:

- First, the requirements for using the CONTROL WORD must be met. See above.
- When the power is first connected, the state of the drive is not ready to switch on. See dotted lined path ( --- ) in the state diagram below.
- Use the CONTROL WORD to step through the state machine states until the OPERATING state is reached, meaning that the drive is running and follows the given reference. See table below.

Step	CONTROL WORD Value	Description
1	CW = 0000 0000 0000 0110 <div style="display: flex; justify-content: space-around; width: 100%;"> <div style="text-align: center;">  bit 15</div> <div style="text-align: center;">  bit 0</div> </div>	This CW value changes the drive state to READY TO SWITCH ON.
2		Wait at least 100 ms before proceeding.
3	CW = 0000 0000 0000 0111	This CW value changes the drive state to READY TO OPERATE.
4	CW = 0000 0000 0000 1111	This CW value changes the drive state to OPERATION ENABLED. The drive starts, but will not accelerate.
5	CW = 0000 0000 0010 1111	This CW value releases the ramp function generator (RFG) output, and changes the drive state to RFG: ACCELERATOR ENABLED.
6	CW = 0000 0000 0110 1111	This CW value releases the ramp function generator (RFG) output, and changes the drive state to OPERATING. The drive accelerates to the given reference and follows the reference.



The state diagram below describes the start-stop function of CONTROL WORD (CW) and STATUS WORD (SW) bits for the ABB Drives profile.

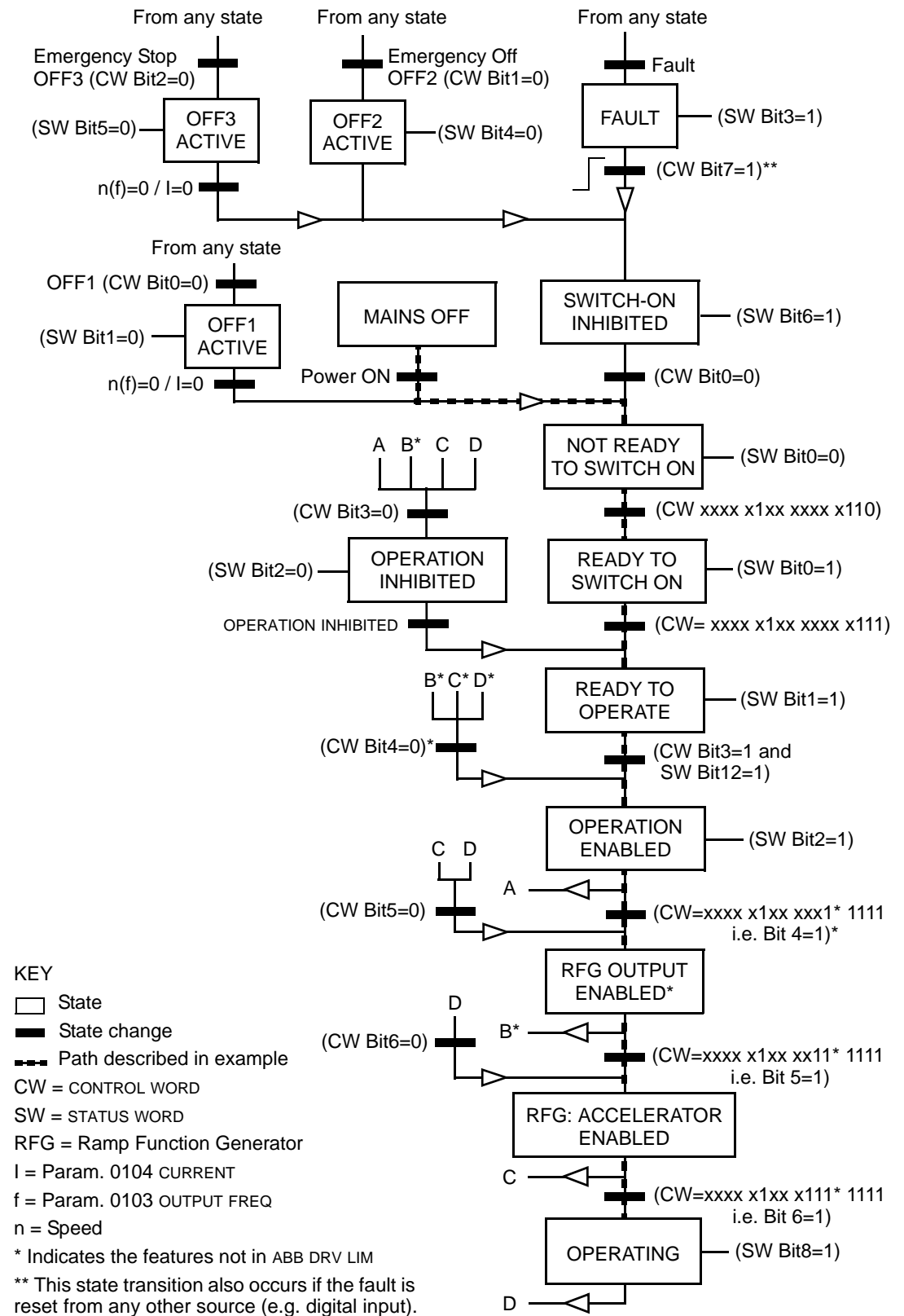

## Reference Scaling

### ABB Drives and DCU Profiles

The following table describes REFERENCE scaling for the ABB Drives and DCU profiles.

ABB Drives and DCU Profiles				
Reference	Range	Reference Type	Scaling	Remarks
REF1	-32767 ... +32767	Speed or frequency	-20000 = <b>-(par. 1105)</b> 0 = 0 +20000 = <b>(par. 1105)</b> (20000 corresponds to 100%)	Final reference limited by 1104/1105. Actual motor speed limited by 2001/2002 (speed) or 2007/2008 (frequency).
REF2	-32767 ... +32767	Speed or frequency	-10000 = <b>-(par. 1108)</b> 0 = 0 +10000 = <b>(par. 1108)</b> (10000 corresponds to 100%)	Final reference limited by 1107/1108. Actual motor speed limited by 2001/2002 (speed) or 2007/2008 (frequency).
		Torque	-10000 = <b>-(par. 1108)</b> 0 = 0 +10000 = <b>(par. 1108)</b> (10000 corresponds to 100%)	Final reference limited by 2015/2017 (torque1) or 2016/2018 (torque2).
		PID Reference	-10000 = <b>-(par. 1108)</b> 0 = 0 +10000 = <b>(par. 1108)</b> (10000 corresponds to 100%)	Final reference limited by 4012/4013 (PID set1) or 4112/4113 (PID set2).

**Note!** The setting of parameter 1104 REF1 MIN and 1107 REF2 MIN has no effect on the scaling of references.

When parameter 1103 REF1 SELECT or 1106 REF2 SELECT is set to COMM+AI1 or COMM\*AI1, the reference is scaled as follows:

ABB Drives and DCU Profiles		
Reference	Value Setting	AI Reference Scaling
REF1	COMM+AI1	$\text{COMM (\%)} + (\text{AI (\%)} - 0.5 * \text{REF1 MAX (\%)})$

ABB Drives and DCU Profiles		
Reference	Value Setting	AI Reference Scaling
REF1	COMM*AI1	$\text{COMM (\%)} * (\text{AI (\%)} / 0.5 * \text{REF1 MAX (\%)})$ <p>(100 - 0.5 * (par. 1105))%</p>
REF2	COMM+AI1	$\text{COMM (\%)} + (\text{AI (\%)} - 0.5 * \text{REF2 MAX (\%)})$ <p>(100 + 0.5 * (Par. 1108))%</p> <p>(100 - 0.5 * (par. 1108))%</p>
REF2	COMM*AI1	$\text{COMM (\%)} * (\text{AI (\%)} / 0.5 * \text{REF2 MAX (\%)})$

*Reference Handling*

Use group 10 parameters to configure for control of rotation direction for each control location (EXT1 and EXT2). The following diagrams illustrate how group 10 parameters and the sign of the fieldbus reference interact to produce REFERENCE values (REF1 and REF2). Note, fieldbus references are bipolar, that is they can be positive or negative.

ABB Drives Profile		
Parameter	Value Setting	AI Reference Scaling
1003 DIRECTION	1 (FORWARD)	
1003 DIRECTION	2 (REVERSE)	
1003 DIRECTION	3 (REQUEST)	

# Fieldbus Adapter

---

## Overview

The ACS550 can be set up to accept control from an external system using standard serial communication protocols. When using serial communication, the ACS550 can either:

- Receive all of its control information from the fieldbus, or
- Be controlled from some combination of fieldbus control and other available control locations, such as digital or analog inputs, and the control panel.

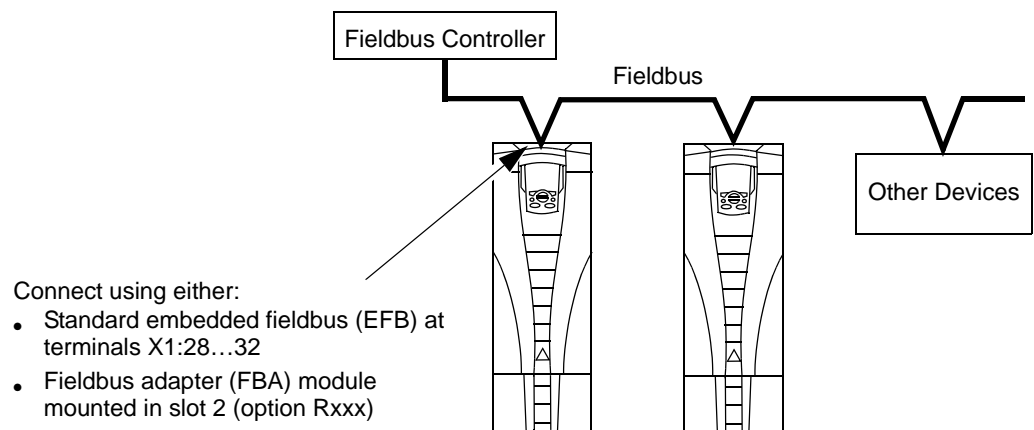

Two basic serial communications configurations are available:

- Embedded fieldbus (EFB) – See "Embedded Fieldbus" on page 149.
- Fieldbus adapter (FBA) – With one of the optional FBA modules in the drive's expansion slot 2, the drive can communicate to a control system using one of the following protocols:
  - Profibus-DP®
  - LonWorks®
  - CANopen®
  - DeviceNet®
  - ControlNet®

The ACS550 detects automatically which communication protocol is used by the plug-in fieldbus adapter. The default settings for each protocol assume that the profile used is the protocol's industry-standard drive profile (e.g. PROFIdrive for PROFIBUS, AC/DC Drive for DeviceNet). All of the FBA protocols can also be configured for the ABB Drives profile.

Configuration details depend on the protocol and profile used. These details are provided in a user's manual supplied with the FBA module.

Details for the ABB Drives profile (which apply for all protocols) are provided in "ABB Drives Profile Technical Data" on page 191.

## Control Interface

In general, the basic control interface between the fieldbus system and the drive consists of:

- Output Words:
  - CONTROL WORD
  - REFERENCE (speed or frequency)
  - Others: The drive supports a maximum of 15 output words. Protocol limits may further restrict the total.
- Input Words:
  - STATUS WORD
  - Actual Value (speed or frequency)
  - Others: The drive supports a maximum of 15 input words. Protocol limits may further restrict the total.

---

**Note!** The words “output” and “input” are used as seen from the fieldbus controller point of view. For example an output describes data flow from the fieldbus controller to the drive and appears as an input from the drive point of view.

---

The meanings of the controller interface words are not restricted by the ACS550. However, the profile used may set particular meanings.

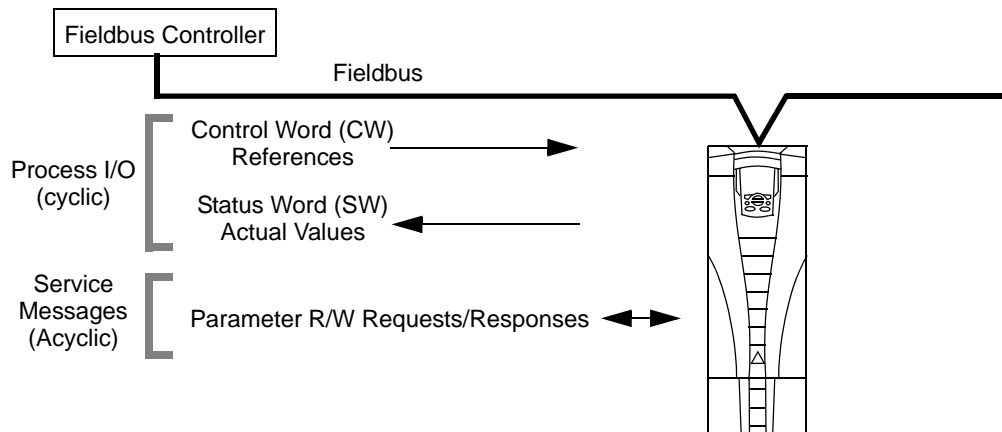

### Control Word

The CONTROL WORD is the principal means for controlling the drive from a fieldbus system. The fieldbus controller sends the CONTROL WORD to the drive. The drive switches between states according to the bit-coded instructions in the CONTROL WORD. Using the CONTROL WORD requires that:

- The drive is in remote (REM) control.
- The serial communication channel is defined as the source for controlling commands from EXT1 (set using parameters 1001 EXT1 COMMANDS and 1102 EXT1/EXT2 SEL).
- The external plug-in fieldbus adapter is activated:

- Parameter 9802 COMM PROT SEL = 4 (EXT FBA).
- The external plug-in fieldbus adapter is configured to use the drive profile mode or drive profile objects.

The content of the CONTROL WORD depends on the protocol/profile used. See the user's manual provided with the FBA module and/or the "ABB Drives Profile Technical Data".

#### *Status Word*

The STATUS WORD is a 16-bit word containing status information, sent by the drive to the fieldbus controller. The content of the STATUS WORD depends on the protocol/profile used. See the user's manual provided with the FBA module and/or the "ABB Drives Profile Technical Data" section.

#### *Reference*

The contents of each REFERENCE word:

- Can be used, as speed or frequency reference.
- Is a 16-bit word comprised of a sign bit and a 15-bit integer.
- Negative references (indicating reversed rotation direction) are indicated by the two's complement of the corresponding positive reference value.

The use of a second reference (REF2) is supported only when a protocol is configured for the ABB Drives profile.

Reference scaling is fieldbus type specific. See the user's manual provided with the FBA module and/or the following sections as appropriate:

- "ABB Drives Profile Technical Data"
- "Generic Profile Technical Data"

#### *Actual Values*

Actual Values are 16-bit words containing information on selected operations of the drive. Drive Actual Values (for example, group 01 parameters) can be mapped to Input Words using group 51 parameters (protocol-dependent, but typically parameters 5104...5126).

## **Planning**

Network planning should address the following questions:

- What types and quantities of devices must be connected to the network?
- What control information must be sent down to the drives?
- What feedback information must be sent from the drives to the controlling system?

## Mechanical and Electrical Installation – FBA



**Warning!** Connections should be made only while the drive is disconnected from the power source.

### Overview

The FBA (fieldbus adapter) is a plug-in module that fits in the drive's expansion slot 2. The module is held in place with plastic retaining clips and two screws. The screws also ground the shield for the module cable, and connect the module GND signals to the drive control board.

On installation of the module, electrical connection to the drive is automatically established through the 34-pin connector.

### Mounting Procedure

**Note!** Install the input power and motor cables first.

1. Insert the module carefully into the drive expansion slot 2 until the retaining clips lock the module into position.
2. Fasten the two screws (included) to the stand-offs.

**Note!** Correct installation of the screws is essential for fulfilling the EMC requirements and for proper operation of the module.

3. Open the appropriate knockout in the conduit box and install the cable clamp for the network cable.
4. Route the network cable through the cable clamp.
5. Connect the network cable to the module's network connector.
6. Tighten the cable clamp.
7. Install the conduit box cover (1 screw).
8. For configuration information see the following:
  - "Communication Set-up – FBA" below.
  - "Activate Drive Control Functions – FBA" on page 185.
  - The protocol specific documentation provided with the module.

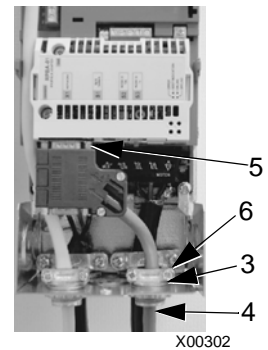
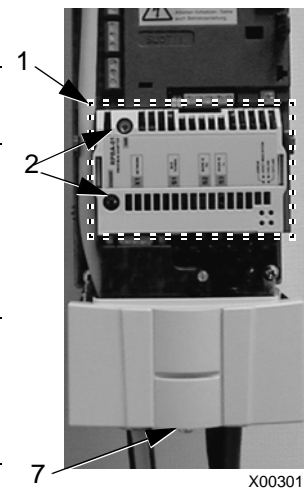



## Communication Set-up – FBA

### Serial Communication Selection

To activate the serial communication, use parameter 9802 COMM PROTOCOL SEL. Set 9802 = 4 (EXT FBA).

### Serial Communication Configuration

Setting 9802, together with mounting a particular FBA module, automatically sets the appropriate default values in parameters that define the communication process. These parameters and descriptions are defined in the user's manual supplied with the FBA module.

- Parameter 5101 is automatically configured.
- Parameters 5102...5126 are protocol-dependent and define, for example, the profile used, and additional I/O words. These parameters are referred to as the fieldbus configuration parameters. See the user's manual provided with the FBA module for details on the fieldbus configuration parameters.
- Parameter 5127 forces the validation of changes to parameters 5102...5126. If parameter 5127 is not used, changes to parameters 5102...5126 take affect only after the drive power is cycled.
- Parameters 5128...5133 provide data about the FBA module currently installed (e.g. component versions and status).

The Parameters Description section lists the group 51 parameters.

## Activate Drive Control Functions – FBA

Fieldbus control of various drive functions requires configuration to:

- Tell the drive to accept fieldbus control of the function.
- Define as a fieldbus input, any drive data required for control.
- Define as a fieldbus output, any control data required by the drive.

The following sections describe, at a general level, the configuration required for each control function. The last column in each table below is deliberately blank. See the user's manual supplied with the FBA module for the appropriate entry.

### Start/Stop Direction Control

Using the fieldbus for start/stop/direction control of the drive requires:

- Drive parameter values set as defined below.
- Fieldbus controller supplied command(s) in the appropriate location. (The location is defined by the Protocol Reference, which is protocol dependent.)

Drive Parameter		Value	Description	Protocol Reference
1001	EXT1 COMMANDS	10 (COMM)	Start/Stop controlled by fieldbus with Ext1 selected.	

Drive Parameter		Value	Description	Protocol Reference
1002	EXT2 COMMANDS	10 (COMM)	Start/Stop by controlled fieldbus with Ext2 selected.	
1003	DIRECTION	3 (REQUEST)	Direction controlled by fieldbus.	

### Input Reference Select

Using the fieldbus to provide input reference to the drive requires:

- Drive parameter value set as defined below.
- Fieldbus controller supplied reference word(s) in the appropriate location. (The location is defined by the Protocol Reference, which is protocol dependent.)

Drive Parameter		Value	Description	Protocol Reference
1102	EXT1/EXT2 SEL	8 (COMM)	Ref. selected by fieldbus. (Required only if 2 references used.)	
1103	REF1 SEL	8 (COMM) 9 (COMM+AI1) 10 (COMM*AI1)	Input reference 1 supplied by fieldbus.	
1106	REF2 SEL	8 (COMM) 9 (COMM+AI) 10 (COMM*AI)	Input reference 1 supplied by fieldbus. (Required only if 2 references used.)	

---

**Note!** Multiple references are supported only when using the ABB Drives profile.

---

### Scaling

Where required, REFERENCES can be scaled. See the "Reference Scaling" in the following sections, as appropriate:

- "ABB Drives Profile Technical Data"
- "Generic Profile Technical Data"

### System Control

Using the fieldbus for miscellaneous drive control requires:

- Drive parameter values set as defined below.
- Fieldbus controller command(s) in the appropriate location. (The location is defined by the Protocol Reference, which is protocol dependent.)

Drive Parameter		Value	Description	Protocol Reference
1601	RUN ENABLE	7 (COMM)	Run enable by fieldbus.	
1604	FAULT RESET SEL	8 (COMM)	Fault reset by fieldbus.	
1607	PARAM SAVE	1 (SAVE)	Saves altered parameters to memory (then value returns to 0).	

## Relay Output Control

Using the fieldbus for relay output control requires:

- Drive parameter values set as defined below.
- Fieldbus controller supplied, binary coded, relay command(s) in the appropriate location. (The location is defined by the Protocol Reference, which is protocol dependent.)

Drive Parameter		Value	Description	Protocol Reference
1401	RELAY OUTPUT 1	35 (COMM)	Relay Output 1 controlled by fieldbus.	
1402	RELAY OUTPUT 2	36 (COMM(-1))	Relay Output 2 controlled by fieldbus.	
1403	RELAY OUTPUT 3		Relay Output 3 controlled by fieldbus.	
1410 <sup>1</sup>	RELAY OUTPUT 4		Relay Output 4 controlled by fieldbus.	
1411 <sup>1</sup>	RELAY OUTPUT 5		Relay Output 5 controlled by fieldbus.	
1412 <sup>1</sup>	RELAY OUTPUT 6		Relay Output 6 controlled by fieldbus.	

1. More than 3 relays requires the addition of a relay extension module.

**Note!** Relay status feedback occurs without configuration as defined below.

Drive Parameter		Value	Protocol Reference
0122	RO 1-3 STATUS	Relay 1...3 status.	
0123	RO 4-6 STATUS	Relay 4...6 status.	

## Analog Output Control

Using the fieldbus for analog output control (e.g. PID setpoint) requires:

- Drive parameter values set as defined below.
- Fieldbus controller supplied analog value(s) in the appropriate location. (The location is defined by the Protocol Reference, which is protocol dependent.)

Drive Parameter		Value	Description	Protocol Reference
1501	AO1 CONTENT SEL	135 (COMM VALUE 1)	Analog Output 1 controlled by writing to parameter 0135.	–
0135	COMM VALUE 1	–		
1502 ... 1505	AO1 CONTENT MIN ... MAXIMUM AO1	Set appropriate values.	Used for scaling	–
1506	FILTER AO1		Filter time constant for AO1.	–
1507	AO2 CONTENT SEL	136 (COMM VALUE 2)	Analog Output 2 controlled by writing to parameter 0136.	–
0136	COMM VALUE 2	–		
1508 ... 1511	AO2 CONTENT MIN ... MAXIMUM AO2	Set appropriate values.	Used for scaling	–
1512	FILTER AO2		Filter time constant for AO2.	–

### PID Control Setpoint Source

Using the following settings to select the fieldbus as the setpoint source for PID loops:

Drive Parameter		Value	Setting	Protocol Reference
4010	SET POINT SEL (Set 1)	8 (COMM VALUE 1)	Setpoint is input reference 2 (+/-* AI1)	
4110	SET POINT SEL (Set 2)	9 (COMM + AI1)		
4210	SET POINT SEL (Ext/Trim)	10 (COMM*AI1)		

### Communication Fault

When using fieldbus control, specify the drive's action if serial communication is lost.

Drive Parameter	Value	Description
3018	COMM FAULT FUNC 0 (NOT SEL) 1 (FAULT) 2 (CONST SP7) 3 (LAST SPEED)	Set for appropriate drive response.
3019	COMM FAULT TIME	Set time delay before acting on a communication loss.

### Feedback from the Drive – FBA

Inputs to the controller (drive outputs) have pre-defined meanings established by the protocol. This feedback does not require drive configuration. The following table lists a sample of feedback data. For a complete listing, see all parameters listed in "Complete Parameter Descriptions".

Drive Parameter	Protocol Reference
0102	SPEED
0103	FREQ OUTPUT
0104	CURRENT
0105	TORQUE
0106	POWER
0107	DC BUS VOLT
0109	OUTPUT VOLTAGE
0301	FB STATUS WORD – bit 0 (STOP)
0301	FB STATUS WORD – bit 2 (REV)
0118	DI1-3 STATUS – bit 1 (DI3)

### Scaling

To scale the drive parameter values see the "Actual Value Scaling" in the following sections, as appropriate:

- "ABB Drives Profile Technical Data"
- "Generic Profile Technical Data"

## Diagnostics – FBA

### Fault Handling

The ACS550 provides fault information as follows:

- The control panel display shows a fault code and text. See "Diagnostics" starting on page 201 for a complete description.
- Parameters 0401 LAST FAULT, 0402 PREVIOUS FAULT1 and 0403 PREVIOUS FAULT2 store the most recent faults.
- For fieldbus access, the drive reports faults as a hexadecimal value, assigned and coded according to the DRIVECOM specification. See table below. Not all profiles support requesting fault codes using this specification. For profiles that support this specification, the profile documentation defines the proper fault request process.

	Drive Fault Code	Fieldbus Fault Code (DRIVECOM specification)
1	OVERCURRENT	2310h
2	DC OVERVOLT	3210h
3	DEV OVERTEMP	4210h
4	SHORT CIRC	2340h
5	Reserved	FF6Bh
6	DC UNDERVOLT	3220h
7	AI1 LOSS	8110h
8	AI2 LOSS	8110h
9	MOT TEMP	4310h
10	PANEL LOSS	5300h
11	ID RUN FAIL	FF84h
12	MOTOR STALL	7121h
14	EXTERNAL FLT 1	9000h
15	EXTERNAL FLT 2	9001h
16	EARTH FAULT	2330h
17	UNDERLOAD	FF6Ah
18	THERM FAIL	5210h
19	OPEX LINK	7500h
20	OPEX PWR	5414h
21	CURR MEAS	2211h
22	SUPPLY PHASE	3130h
23	ENCODER ERR	7301h
24	OVERSPEED	7310h
25	Reserved	FF80h
26	DRIVE ID	5400h
27	CONFIG FILE	630Fh

Drive Fault Code		Fieldbus Fault Code (DRIVECOM specification)
28	SERIAL 1 ERR	7510h
29	EFB CONFIG FILE	6306h
30	FORCE TRIP	FF90h
31	EFB 1	FF92h
32	EFB 2	FF93h
33	EFB 3	FF94h
34	MOTOR PHASE	FF56h
35	OUTPUT WIRING	FF95h
36	INCOMP SWTYPE	630Fh
101	SERF CORRUPT	FF55h
102	Reserved	FF55h
103	SERF MACRO	FF55h
104	Reserved	FF55h
105	Reserved	FF55h
201	DSP T1 OVERLOAD	6100h
202	DSP T2 OVERLOAD	6100h
203	DSP T3 OVERLOAD	6100h
204	DSP STACK ERROR	6100h
205	Reserved (obsolete)	5000h
206	OMIO ID ERROR	5000h
207	EFB LOAD ERR	6100h
1000	PAR HZRPM	6320h
1001	PAR PFCREFNG	6320h
1002	Reserved (obsolete)	6320h
1003	PAR AI SCALE	6320h
1004	PAR AO SCALE	6320h
1005	PAR PCU 2	6320h
1006	EXT ROMISSING	6320h
1007	PAR FBUSMISSING	6320h
1008	PAR PFCWOSCALAR	6320h
1009	PAR PCU1	6320h
1012	PAR PFC IO 1	6320h
1013	PAR PFC IO 2	6320h
1014	PAR PFC IO 3	6320h

### Serial Communication Diagnostics

Besides the drive fault codes, the FBA module has diagnostic tools. Refer to the user's manual supplied with the FBA module.

## ABB Drives Profile Technical Data

### Overview

The ABB Drives profile provides a standard profile that can be used on multiple protocols, including protocols available on the FBA module. This section describes the ABB Drives profile implemented for FBA modules.

### Control Word

As described earlier in "Control Interface" the CONTROL WORD is the principal means for controlling the drive from a fieldbus system.

The following table and the state diagram later in this sub-section describe the CONTROL WORD content for the ABB Drives profile.

ABB Drives Profile (FBA) CONTROL WORD				
Bit	Name	Value	Commanded State	Comments
0	OFF1 CONTROL	1	READY TO OPERATE	Enter READY TO OPERATE
		0	EMERGENCY OFF	Drive ramps to stop according to currently active deceleration ramp (2203 or 2205) Normal command sequence: <ul style="list-style-type: none"> <li>• Enter OFF1 ACTIVE</li> <li>• Proceed to READY TO SWITCH ON, unless other interlocks (OFF2, OFF3) are active.</li> </ul>
1	OFF2 CONTROL	1	OPERATING	Continue operation (OFF2 inactive)
		0	EMERGENCY OFF	Drive coasts to stop. Normal command sequence: <ul style="list-style-type: none"> <li>• Enter OFF2 ACTIVE</li> <li>• Proceed to SWITCHON INHIBITED</li> </ul>
2	OFF3 CONTROL	1	OPERATING	Continue operation (OFF3 inactive)
		0	EMERGENCY STOP	Drive stops within in time specified by parameter 2208. Normal command sequence: <ul style="list-style-type: none"> <li>• Enter OFF3 ACTIVE</li> <li>• Proceed to SWITCH ON INHIBITED</li> </ul> <b>WARNING! Be sure motor and driven equipment can be stopped using this mode.</b>
3	INHIBIT OPERATION	1	OPERATION ENABLED	Enter OPERATION ENABLED (Note the Run enable signal must be active. See 1601. If 1601 is set to COMM, this bit also activates the Run Enable signal.)
		0	OPERATION INHIBITED	Inhibit operation. Enter OPERATION INHIBITED
4	RAMP_OUT_ZERO	1	NORMAL OPERATION	Enter RAMP FUNCTION GENERATOR: ACCELERATION ENABLED
		0	RFG OUT ZERO	Force ramp function generator output to Zero. Drive ramps to stop (current and DC voltage limits in force).

ABB Drives Profile (FBA) CONTROL WORD				
Bit	Name	Value	Commanded State	Comments
5	RAMP_HOLD	1	RFG OUT ENABLED	Enable ramp function. Enter RAMP FUNCTION GENERATOR: ACCELERATOR ENABLED
		0	RFG OUT HOLD	Halt ramping (Ramp Function Generator output held)
6	RAMP_IN_ZERO	1	RFG INPUT ENABLED	Normal operation. Enter OPERATING
		0	RFG INPUT ZERO	Force Ramp Function Generator input to zero.
7	RESET	0=>1	RESET	Fault reset if an active fault exists (Enter SWITCH-ON INHIBITED). Effective if 1604 = COMM.
		0	OPERATING	Continue normal operation
8...9	Unused			
10	REMOTE_CMD	1		Fieldbus control enabled
		0		<ul style="list-style-type: none"> <li>CW ≠ 0 or Ref ≠ 0: Retain last CW and Ref.</li> <li>CW = 0 and Ref = 0: Fieldbus control enabled.</li> <li>Ref and deceleration/acceleration ramp are locked.</li> </ul>
11	EXT CTRL LOC	1	EXT2 SELECT	Select external control location 2 (EXT2). Effective if 1102 = COMM.
		0	EXT1 SELECT	Select external control location 1 (EXT1). Effective if 1102 = COMM.
12...15	Unused			

### Status Word

As described earlier in "Control Interface", the contents of the STATUS WORD is status information, sent by the drive to the master station. The following table and the state diagram later in this sub-section describe the status word content.

ABB Drives Profile (FBA) STATUS WORD			
Bit	Name	Value	Description (Correspond to states/boxes in the state diagram)
0	RDY_ON	1	READY TO SWITCH ON
		0	NOT READY TO SWITCH ON
1	RDY_RUN	1	READY TO OPERATE
		0	OFF1 ACTIVE
2	RDY_REF	1	OPERATION ENABLED
		0	OPERATION INHIBITED
3	TRIPPED	0...1	FAULT
		0	No fault



<b>ABB Drives Profile (FBA) STATUS WORD</b>			
<b>Bit</b>	<b>Name</b>	<b>Value</b>	<b>Description (Correspond to states/boxes in the state diagram)</b>
4	OFF_2_STA	1	OFF2 inactive
		0	<b>OFF2 ACTIVE</b>
5	OFF_3_STA	1	OFF3 inactive
		0	<b>OFF3 ACTIVE</b>
6	SWC_ON_INHIB	1	SWITCH-ON INHIBIT ACTIVE
		0	SWITCH-ON INHIBIT NOT ACTIVE
7	ALARM	1	Warning/alarm (See "Alarm Listing" in the "Diagnostics" section for details on alarms.)
		0	No warning/alarm
8	AT_SETPOINT	1	OPERATING. Actual value equals (within tolerance limits) the reference value.
		0	Actual value is outside tolerance limits (not equal to reference value).
9	REMOTE	1	Drive control location: REMOTE (EXT1 or EXT2)
		0	Drive control location: LOCAL
10	ABOVE_LIMIT	1	Supervised parameter's value $\geq$ supervision high limit. Bit remains "1" until supervised parameter's value < supervision low limit. See group 32, Supervision
		0	Supervised parameter's value < supervision low limit. Bit remains "0" until supervised parameter's value > supervision high limit. See group 32, Supervision
11	EXT CTRL LOC	1	External control location 2 (EXT2) selected
		0	External control location 1 (EXT1) selected
12	EXT RUN ENABLE	1	External Run Enable signal received
		0	No External Run Enable signal received
13... 15	Unused		

The state diagram below describes the start-stop function of CONTROL WORD (CW) and STATUS WORD (SW) bits.

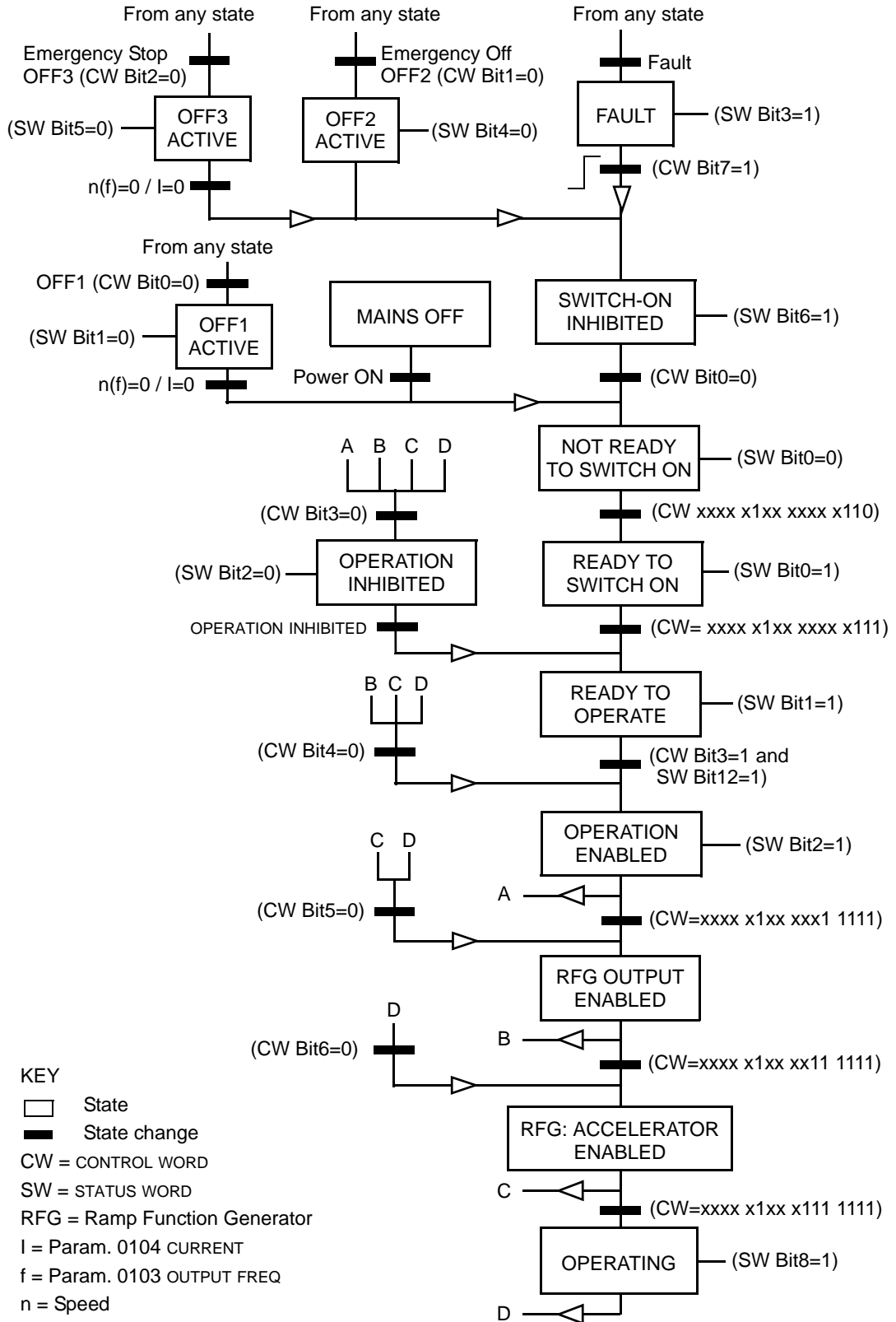

**Reference**

As described earlier in "Control Interface", the REFERENCE word is a speed or frequency reference.

*Reference Scaling*

The following table describes REFERENCE scaling for the ABB Drives profile.

ABB Drives Profile (FBA)				
Reference	Range	Reference Type	Scaling	Remarks
REF1	-32767... +32767	Speed or frequency	-20000 = <b>-(par. 1105)</b> 0 = 0 +20000 = <b>(par. 1105)</b> (20000 corresponds to 100%)	Final reference limited by 1104/1105. Actual motor speed limited by 2001/2002 (speed) or 2007/2008 (frequency).
REF2	-32767... +32767	Speed or frequency	-10000 = <b>-(par. 1108)</b> 0 = 0 +10000 = <b>(par. 1108)</b> (10000 corresponds to 100%)	Final reference limited by 1107/1108. Actual motor speed limited by 2001/2002 (speed) or 2007/2008 (frequency).
		Torque	-10000 = <b>-(par. 1108)</b> 0 = 0 +10000 = <b>(par. 1108)</b> (10000 corresponds to 100%)	Final reference limited by 2015/2017 (torque1) or 2016/2018 (torque2).
		PID Reference	-10000 = <b>-(par. 1108)</b> 0 = 0 +10000 = <b>(par. 1108)</b> (10000 corresponds to 100%)	Final reference limited by 4012/4013 (PID set1) or 4112/4113 (PID set2).

**Note!** The setting of parameter 1104 REF1 MIN and 1107 REF2 MIN has no effect on the scaling of references.

When parameter 1103 REF1 SELECT or 1106 REF2 SELECT is set to COMM+AI1 or COMM\*AI1, the reference is scaled as follows:

ABB Drives Profile (FBA)		
Reference	Value Setting	AI Reference Scaling
REF1	COMM+AI1	$\text{COMM (\%)} + (\text{AI (\%)} - 0.5 \cdot \text{REF1 MAX (\%)})$

ABB Drives Profile (FBA)		
Reference	Value Setting	AI Reference Scaling
REF1	COMM*AI1	$\text{COMM (\%)} * (\text{AI (\%)} / 0.5 * \text{REF1 MAX (\%)})$
REF2	COMM+AI1	$\text{COMM (\%)} + (\text{AI (\%)} - 0.5 * \text{REF2 MAX (\%)})$
REF2	COMM*AI1	$\text{COMM (\%)} * (\text{AI (\%)} / 0.5 * \text{REF2 MAX (\%)})$

*Reference Handling*

Use group 10 parameters to configure for control of rotation direction for each control location (EXT1 and EXT2). The following diagrams illustrate how group 10 parameters and the sign of the fieldbus reference interact to produce REFERENCE values (REF1 and REF2). Note, fieldbus references are bipolar, that is they can be positive or negative.

ABB Drives Profile		
Parameter	Value Setting	AI Reference Scaling
1003 DIRECTION	1 (FORWARD)	
1003 DIRECTION	2 (REVERSE)	
1003 DIRECTION	3 (REQUEST)	

## Actual Value

As described earlier in "Control Interface", Actual Values are words containing drive values.

### Actual Value Scaling

The scaling of the integers sent to the fieldbus as Actual Values depends on the resolution of the selected drive parameter. Except as noted for Data Words 5 and 6 below, scale the feedback integer using the resolution listed for the parameter in the "Complete Parameter List for ACS550" section. For example:

Feedback Integer	Parameter Resolution	Scaled Value
1	0.1 mA	$1 * 0.1 \text{ mA} = 0.1 \text{ mA}$
10	0.1%	$10 * 0.1\% = 1\%$

Data words 5 and 6 are scaled as follows:

ABB Drives Profile		
Data Word	Contents	Scaling
5	ACTUAL SPEED	-20000 ... +20000 = -(par. 1105) ... +(par. 1105)
6	TORQUE	-10000 ... +10000 = -100% ... +100%

### Actual Value Mapping

See the user's manual supplied with the FBA module.

## Generic Profile Technical Data

### Overview

The generic profile aims to fulfill the industry-standard drive profile for each protocol (e.g. PROFIdrive for PROFIBUS, AC/DC Drive for DeviceNet).

### Control Word

As described earlier in "Control Interface" the CONTROL WORD is the principal means for controlling the drive from a fieldbus system. For specific CONTROL WORD content, see the user's manual provided with the FBA module.

### Status Word

As described earlier in "Control Interface", the contents of the STATUS WORD is status information, sent by the drive to the master station. For specific STATUS WORD content, see the user's manual provided with the FBA module.

### Reference

As described earlier in "Control Interface", the REFERENCE word is a speed or frequency reference.

---

**Note!** REF2 is not supported by the Generic Drive profiles.

---

### Reference Scaling

REFERENCE scaling is fieldbus type specific. However, at the drive, the meaning of a 100% REFERENCE value is fixed as described in the table below. For a detailed description on the range and scaling of the REFERENCE, see the user's manual supplied with the FBA module.

Generic Profile				
Reference	Range	Reference Type	Scaling	Remarks
REF	Fieldbus specific	Speed	-100% = <b>-(par. 9908)</b> 0 = 0 +100 = <b>(par. 9908)</b>	Final reference limited by 1104/1105. Actual motor speed limited by 2001/2002 (speed).
		Frequency	-100% = <b>-(par. 9907)</b> 0 = 0 +100 = <b>(par. 9907)</b>	Final reference limited by 1104/1105. Actual motor speed limited by 2007/2008 (frequency).

### Actual Values

As described earlier in "Control Interface", Actual Values are words containing drive values.

### Actual Value Scaling

For Actual Values, scale the feedback integer using the parameter's resolution. (See "Complete Parameter List for ACS550" section for parameter resolutions.) For example:

Feedback Integer	Parameter Resolution	(Feedback Integer) * (Parameter Resolution) = Scaled Value
1	0.1 mA	1 * 0.1 mA = 0.1 mA
10	0.1%	10 * 0.1% = 1%

Where parameters are in percent, the "Complete Parameter List for ACS550" section specifies what parameter corresponds to 100%. In such cases, to convert from percent to engineering units, multiply by the value of the parameter that defines 100% and divide by 100%. For example:

Feedback Integer	Parameter Resolution	Value of the Parameter that defines 100%	(Feedback Integer) * (Parameter Resolution) * (Value of 100% Ref.) / 100% = Scaled Value
10	0.1%	1500 rpm <sup>1</sup>	10 * 0.1% * 1500 RPM / 100% = 15 rpm
100	0.1%	500 Hz <sup>2</sup>	100 * 0.1% * 500 Hz / 100% = 50 Hz

1. Assuming, for the sake of this example, that the Actual Value uses parameter 9908 MOT NOM SPEED as the 100% reference, and that 9908 = 1500 rpm.
2. Assuming, for the sake of this example, that the Actual Value uses parameter 9907 MOT NOM FREQ as the 100% reference, and that 9907 = 500 Hz.

### Actual Value Mapping

See the user's manual supplied with the FBA module.



# Diagnosics

---



**Warning! Do not attempt any measurement, parts replacement or other service procedure not described in this manual. Such action will void the warranty, may endanger correct operation, and increase downtime and expense.**

---



**Warning! All electrical installation and maintenance work described in this chapter should only be undertaken by qualified service personnel. The Safety instructions on the first pages of this manual must be followed.**

---

## Diagnostic Displays

The drive detects error situations and reports them using:

- The green and red LED on the body of the drive
- The status LED on the control panel (if an Assistant control panel is attached to the drive)
- The control panel display (if a control panel is attached to the drive)
- The Fault Word and Alarm Word parameter bits (parameters 0305 to 0309). See "Group 03: FB Actual Signals" on page 70 for the bit definitions.

The form of the display depends on the severity of the error. You can specify the severity for many errors by directing the drive to:

- Ignore the error situation.
- Report the situation as an alarm.
- Report the situation as a fault.

### Red – Faults

The drive signals that it has detected a severe error, or fault, by:

- Enabling the red LED on the drive (LED is either steady on or blinking).
- Setting an appropriate bit in a Fault Word parameter (0305 to 0307).
- Overriding the control panel display with the display of a fault code.
- Stopping the motor (if it was on).

The fault code on the control panel display is temporary. Pressing any of the following buttons removes the fault message: MENU, ENTER, UP button, or DOWN button. The message reappears after a few seconds if the control panel is not touched and the fault is still active.

## Flashing Green – Alarms

For less severe errors, called alarms, the diagnostic display is advisory. For these situations, the drive is simply reporting that it had detected something “unusual.” In these situations, the drive:

- Flashes the green LED on the drive (does not apply to alarms that arise from control panel operation errors).
- Sets an appropriate bit in an Alarm Word parameter (0308 or 0309). See "Group 03: FB Actual Signals" on page 70 for the bit definitions.
- Overrides the control panel display with the display of an alarm code and/or name.

Alarm messages disappear from the control panel display after a few seconds. The message returns periodically as long as the alarm condition exists.

## Correcting Faults

The recommended corrective action for faults is:

- Use the "Fault Listing" table below to find and address the root cause of the problem.
- Reset the drive. See "Fault Resetting" on page 207.

## Fault Listing

Fault Code	Fault Name In Panel	Description and Recommended Corrective Action
1	OVERCURRENT	Output current is excessive. Check for and correct: <ul style="list-style-type: none"> <li>• Excessive motor load.</li> <li>• Insufficient acceleration time (parameters 2202 ACCELER TIME 1 and 2205 ACCELER TIME 2).</li> <li>• Faulty motor, motor cables or connections.</li> </ul>
2	DC OVERVOLT	Intermediate circuit DC voltage is excessive. Check for and correct: <ul style="list-style-type: none"> <li>• Static or transient overvoltages in the input power supply.</li> <li>• Insufficient deceleration time (parameters 2203 DECELER TIME 1 and 2206 DECELER TIME 2).</li> <li>• Undersized brake chopper (if present).</li> <li>• Verify that overvoltage controller is ON (using parameter 2005).</li> </ul>
3	DEV OVERTEMP	Drive heatsink is overheated. Temperature is at or above limit. R1...R4 & R7/R8: 115 °C (239 °F) R5/R6: 125 °C (257 °F) Check for and correct: <ul style="list-style-type: none"> <li>• Fan failure.</li> <li>• Obstructions in the air flow.</li> <li>• Dirt or dust coating on the heat sink.</li> <li>• Excessive ambient temperature.</li> <li>• Excessive motor load.</li> </ul>

<b>Fault Code</b>	<b>Fault Name In Panel</b>	<b>Description and Recommended Corrective Action</b>
4	SHORT CIRC	Fault current. Check for and correct: <ul style="list-style-type: none"> <li>• A short-circuit in the motor cable(s) or motor.</li> <li>• Supply disturbances.</li> </ul>
5	Reserved	Not used.
6	DC UNDERVOLT	Intermediate circuit DC voltage is not sufficient. Check for and correct: <ul style="list-style-type: none"> <li>• Missing phase in the input power supply.</li> <li>• Blown fuse.</li> <li>• Undervoltage on mains.</li> </ul>
7	AI1 LOSS	Analog input 1 loss. Analog input value is less than AI1FLT LIMIT (3021). Check for and correct: <ul style="list-style-type: none"> <li>• Source and connection for analog input.</li> <li>• Parameter settings for AI1FLT LIMIT (3021) and 3001 AI&lt;MIN FUNCTION.</li> </ul>
8	AI2 LOSS	Analog input 2 loss. Analog input value is less than AI2FLT LIMIT (3022). Check for and correct: <ul style="list-style-type: none"> <li>• Source and connection for analog input.</li> <li>• Parameter settings for AI2FLT LIMIT (3022) and 3001 AI&lt;MIN FUNCTION.</li> </ul>
9	MOT TEMP	Motor is too hot, based on either the drive's estimate or on temperature feedback. <ul style="list-style-type: none"> <li>• Check for overloaded motor.</li> <li>• Adjust the parameters used for the estimate (3005...3009).</li> <li>• Check the temperature sensors and Group 35 parameters.</li> </ul>
10	PANEL LOSS	Panel communication is lost and either: <ul style="list-style-type: none"> <li>• Drive is in local control mode (the control panel displays LOC), or</li> <li>• Drive is in remote control mode (REM) and is parameterized to accept start/stop, direction or reference from the control panel.</li> </ul> To correct check: <ul style="list-style-type: none"> <li>• Communication lines and connections</li> <li>• Parameter 3002 PANEL COMM ERROR.</li> <li>• Parameters in Group 10: Command Inputs and Group 11: Reference Select (if drive operation is REM).</li> </ul>
11	ID RUN FAIL	The motor ID Run was not completed successfully. Check for and correct: <ul style="list-style-type: none"> <li>• Motor connections</li> <li>• Motor parameters 9905...9909</li> </ul>
12	MOTOR STALL	Motor or process stall. Motor is operating in the stall region. Check for and correct: <ul style="list-style-type: none"> <li>• Excessive load.</li> <li>• Insufficient motor power.</li> <li>• Parameters 3010...3012.</li> </ul>
13	RESERVED	Not used.
14	EXTERNAL FLT 1	Digital input defined to report first external fault is active. See parameter 3003 EXTERNAL FAULT 1.
15	EXTERNAL FLT 2	Digital input defined to report second external fault is active. See parameter 3004 EXTERNAL FAULT 2.

Fault Code	Fault Name In Panel	Description and Recommended Corrective Action
16	EARTH FAULT	Possible ground fault detected in the motor or motor cables. The drive monitors for ground faults while the drive is running and while the drive is not running. Detection is more sensitive when the drive is not running and can produce false positives. Possible corrections: <ul style="list-style-type: none"> <li>• Check for/correct faults in the input wiring.</li> <li>• Verify that motor cable does not exceed maximum specified length.</li> <li>• A delta grounded input power supply and motor cables with high capacitance may result in erroneous error reports during non-running tests. To disable response to fault monitoring when the drive is not running, use parameter 3023 WIRING FAULT. To disable response to all ground fault monitoring, use parameter 3017 EARTH FAULT.</li> </ul>
17	UNDERLOAD	Motor load is lower than expected. Check for and correct: <ul style="list-style-type: none"> <li>• Disconnected load.</li> <li>• Parameters 3013 UNDERLOAD FUNCTION...3015 UNDERLOAD CURVE.</li> </ul>
18	THERM FAIL	Internal fault. The thermistor measuring the internal temperature of the drive is open or shorted. Contact your local ABB sales representative.
19	OPEX LINK	Internal fault. A communication-related problem has been detected on the fiber optic link between the OITF and OINT boards. Contact your local ABB sales representative.
20	OPEX PWR	Internal fault. Low voltage condition detected on OINT power supply. Contact your local ABB sales representative.
21	CURR MEAS	Internal fault. Current measurement is out of range. Contact your local ABB sales representative.
22	SUPPLY PHASE	Ripple voltage in the DC link is too high. Check for and correct: <ul style="list-style-type: none"> <li>• Missing mains phase.</li> <li>• Blown fuse.</li> </ul>
23	ENCODER ERR	The drive is not detecting a valid encoder signal. Check for and correct: <ul style="list-style-type: none"> <li>• Encoder presence and proper connection (reverse wired, loose connection, or short circuit).</li> <li>• Voltage logic levels are outside of the specified range.</li> <li>• A working and properly connected Pulse Encoder Interface Module, OTAC-01.</li> <li>• Wrong value entered in parameter 5001 PULSE NR. A wrong value will only be detected if the error is such that the calculated slip is greater than 4 times the rated slip of the motor.</li> <li>• Encoder is not being used, but parameter 5002 ENCODER ENABLE = 1 (ENABLED).</li> </ul>
24	OVERSPEED	Motor speed is greater than 120% of the larger (in magnitude) of 2001 MINIMUM SPEED or 2002 MAXIMUM SPEED. Check for and correct: <ul style="list-style-type: none"> <li>• Parameter settings for 2001 and 2002.</li> <li>• Adequacy of motor braking torque.</li> <li>• Applicability of torque control.</li> <li>• Brake chopper and resistor.</li> </ul>
25	RESERVED	Not used.
26	DRIVE ID	Internal fault. Configuration Block Drive ID is not valid. Contact your local ABB sales representative.
27	CONFIG FILE	Internal configuration file has an error. Contact your local ABB sales representative.

<b>Fault Code</b>	<b>Fault Name In Panel</b>	<b>Description and Recommended Corrective Action</b>
28	SERIAL 1 ERR	Fieldbus communication has timed out. Check for and correct: <ul style="list-style-type: none"> <li>• Fault setup (3018 COMM FAULT FUNC and 3019 COMM FAULT TIME).</li> <li>• Communication settings (Group 51 or 53 as appropriate).</li> <li>• Poor connections and/or noise on line.</li> </ul>
29	EFB CONFIG FILE	Error in reading the configuration file for the embedded fieldbus.
30	FORCE TRIP	Fault trip forced by the fieldbus. See the fieldbus User's Manual.
31	EFB 1	Fault code reserved for the embedded fieldbus (EFB) protocol application. The meaning is protocol dependent.
32	EFB 2	
33	EFB 3	
34	MOTOR PHASE	Fault in the motor circuit. One of the motor phases is lost. Check for and correct: <ul style="list-style-type: none"> <li>• Motor fault.</li> <li>• Motor cable fault.</li> <li>• Thermal relay fault (if used).</li> <li>• Internal fault.</li> </ul>
35	OUTPUT WIRING	Possible power wiring error detected. When the drive is not running it monitors for an improper connection between the drive input power and the drive output. Check for and correct: <ul style="list-style-type: none"> <li>• Proper input wiring – line voltage is NOT connected to drive output.</li> <li>• The fault can be erroneously declared if the input power is a delta grounded system and motor cable capacitance is large. This fault can be disabled using parameter 3023 WIRING FAULT.</li> </ul>
36	INCOMP SWTYPE	The drive cannot use the software. <ul style="list-style-type: none"> <li>• Internal Fault.</li> <li>• The loaded software is not compatible with the drive.</li> <li>• Call support representative.</li> </ul>
101	SERF CORRUPT	Error internal to the drive. Contact your local ABB sales representative and report the error number.
102	RESERVED	
103	SERF MACRO	
104	RESERVED	
105	RESERVED	
201	DSP T1 OVERLOAD	Error in the system. Contact your local ABB sales representative and report the error number.
202	DSP T2 OVERLOAD	
203	DSP T3 OVERLOAD	
204	DSP STACK ERROR	
205	RESERVED (OBSOLETE)	
206	OMIO ID ERROR	
207	EFB LOAD ERROR	

Faults that indicate conflicts in the parameter settings are listed below.

Fault Code	Fault Name In Panel	Description and Recommended Corrective Action
1000	PAR HZRPM	Parameter values are inconsistent. Check for any of the following: <ul style="list-style-type: none"> <li>• 2001 MINIMUM SPEED &gt; 2002 MAXIMUM SPEED.</li> <li>• 2007 MINIMUM FREQ &gt; 2008 MAXIMUM FREQ.</li> <li>• 2001 MINIMUM SPEED / 9908 MOTOR NOM SPEED is outside proper range (&gt; 50)</li> <li>• 2002 MAXIMUM SPEED / 9908 MOTOR NOM SPEED is outside proper range (&gt; 50)</li> <li>• 2007 MINIMUM FREQ / 9907 MOTOR NOM FREQ is outside proper range (&gt; 50)</li> <li>• 2008 MAXIMUM FREQ / 9907 MOTOR NOM FREQ is outside proper range (&gt; 50)</li> </ul>
1001	PAR PFCREFNG	Parameter values are inconsistent. Check for the following: <ul style="list-style-type: none"> <li>• 2007 MINIMUM FREQ is negative, when 8123 PFC ENABLE is active.</li> </ul>
1003	PAR AI SCALE	Parameter values are inconsistent. Check for any of the following: <ul style="list-style-type: none"> <li>• 1301 AI 1 MIN &gt; 1302 AI 1 MAX.</li> <li>• 1304 AI 2 MIN &gt; 1305 AI 2 MAX.</li> </ul>
1004	PAR AO SCALE	Parameter values are inconsistent. Check for any of the following: <ul style="list-style-type: none"> <li>• 1504 AO 1 MIN &gt; 1505 AO 1 MAX.</li> <li>• 1510 AO 2 MIN &gt; 1511 AO 2 MAX.</li> </ul>
1005	PAR PCU 2	Parameter values for power control are inconsistent: Improper motor nominal kVA or motor nominal power. Check for the following: <ul style="list-style-type: none"> <li>• <math>1.1 \leq (9906 \text{ MOTOR NOM CURR} * 9905 \text{ MOTOR NOM VOLT} * 1.73 / P_N) \leq 3.0</math></li> <li>• Where: <math>P_N = 1000 * 9909 \text{ MOTOR NOM POWER}</math> (if units are kW) or <math>P_N = 746 * 9909 \text{ MOTOR NOM POWER}</math> (if units are HP, e.g. in US)</li> </ul>
1006	PAR EXTROMISSING	Parameter values are inconsistent. Check for the following: <ul style="list-style-type: none"> <li>• Extension relay module not connected and</li> <li>• 1410...1412 RELAY OUTPUTS 4...6 have non-zero values.</li> </ul>
1007	PAR FBUSMISSING	Parameter values are inconsistent. Check for and correct: <ul style="list-style-type: none"> <li>• A parameter is set for fieldbus control (e.g. 1001 EXT1 COMMANDS = 10 (COMM)), but 9802 COMM PROT SEL = 0.</li> </ul>
1008	PAR PFCWOSCALAR	Parameter values are inconsistent – 9904 MOTOR CTRL MODE must be = 3 (SCALAR: SPEED), when 8123 PFC ENABLE is activated.
1009	PAR PCU1	Parameter values for power control are inconsistent: Improper motor nominal frequency or speed. Check for both of the following: <ul style="list-style-type: none"> <li>• <math>1 \leq (60 * 9907 \text{ MOTOR NOM FREQ} / 9908 \text{ MOTOR NOM SPEED}) \leq 16</math></li> <li>• <math>0.8 \leq 9908 \text{ MOTOR NOM SPEED} / (120 * 9907 \text{ MOTOR NOM FREQ} / \text{Motor Poles}) \leq 0.992</math></li> </ul>
1012	PAR PFC IO 1	IO configuration is not complete – not enough relays are parameterized to PFC. Or, a conflict exists between Group 14, parameter 8117, NR OF AUX MOT, and parameter 8118, AUTOCHNG INTERV.
1013	PAR PFC IO 2	IO configuration is not complete – the actual number of PFC motors (parameter 8127, MOTORS) does not match the PFC motors in Group 14 and parameter 8118 AUTOCHNG INTERV.
1014	PAR PFC IO 3	IO configuration is not complete – the drive is unable to allocate a digital input (interlock) for each PFC motor (parameters 8120 INTERLOCKS and 8127 MOTORS).

## Fault Resetting

The ACS550 can be configured to automatically reset certain faults. Refer to parameter Group 31: Automatic Reset.



**Warning! If an external source for start command is selected and it is active, the ACS550 may start immediately after fault reset.**

---

### *Flashing Red LED*

To reset the drive for faults indicated by a flashing red LED:

- Turn the power off for 5 minutes.

### *Red LED*

To reset the drive for faults indicated by a red LED (on, not flashing), correct the problem and do one of the following:

- From the control panel: Press RESET
- Turn the power off for 5 minutes.

Depending on the value of 1604, FAULT RESET SELECT, the following could also be used to reset the drive:

- Digital input
- Serial communication

When the fault has been corrected, the motor can be started.

## History

For reference, the last three fault codes are stored into parameters 0401, 0412, 0413. For the most recent fault (identified by parameter 0401), the drive stores additional data (in parameters 0402...0411) to aid in troubleshooting a problem. For example, parameter 0404 stores the motor speed at the time of the fault.

To clear the fault history (all of the Group 04, Fault History parameters):

1. Using the control panel in Parameters mode, select parameter 0401.
2. Press EDIT (or ENTER on the Basic control panel).
3. Press UP and Down at the same time.
4. Press SAVE.

## Correcting Alarms

The recommended corrective action for alarms is:

- Determine if the Alarm requires any corrective action (action is not always required).
- Use "Alarm Listing" below to find and address the root cause of the problem.

## Alarm Listing

The following table lists the alarms by code number and describes each.

Alarm Code	Display	Description
2001	OVERCURRENT	Current limiting controller is active. Check for and correct: <ul style="list-style-type: none"> <li>Excessive motor load.</li> <li>Insufficient acceleration time (parameters 2202 ACCELER TIME 1 and 2205 ACCELER TIME 2).</li> <li>Faulty motor, motor cables or connections.</li> </ul>
2002	OVERVOLTAGE	Over voltage controller is active. Check for and correct: <ul style="list-style-type: none"> <li>Static or transient overvoltages in the input power supply.</li> <li>Insufficient deceleration time (parameters 2203 DECELER TIME 1 and 2206 DECELER TIME 2).</li> </ul>
2003	UNDERVOLTAGE	Under voltage controller is active. Check for and correct: <ul style="list-style-type: none"> <li>Undervoltage on mains.</li> </ul>
2004	DIR LOCK	The change in direction being attempted is not allowed. Either: <ul style="list-style-type: none"> <li>Do not attempt to change the direction of motor rotation, or</li> <li>Change parameter 1003 DIRECTION to allow direction change (if reverse operation is safe).</li> </ul>
2005	I/O COMM	Fieldbus communication has timed out. Check for and correct: <ul style="list-style-type: none"> <li>Fault setup (3018 COMM FAULT FUNC and 3019 COMM FAULT TIME).</li> <li>Communication settings (Group 51 or 53 as appropriate).</li> <li>Poor connections and/or noise on line.</li> </ul>
2006	AI1 LOSS	Analog input 1 is lost, or value is less than the minimum setting. Check: <ul style="list-style-type: none"> <li>Input source and connections</li> <li>Parameter that sets the minimum (3021)</li> <li>Parameter that sets the Alarm/Fault operation (3001)</li> </ul>
2007	AI2 LOSS	Analog input 2 is lost, or value is less than the minimum setting. Check: <ul style="list-style-type: none"> <li>Input source and connections</li> <li>Parameter that sets the minimum (3022)</li> <li>Parameter that sets the Alarm/Fault operation (3001)</li> </ul>
2008	PANEL LOSS	Panel communication is lost and either: <ul style="list-style-type: none"> <li>Drive is in local control mode (the control panel displays LOC), or</li> <li>Drive is in remote control mode (REM) and is parameterized to accept start/stop, direction or reference from the control panel.</li> </ul> To correct check: <ul style="list-style-type: none"> <li>Communication lines and connections</li> <li>Parameter 3002 PANEL LOSS.</li> <li>Parameters in groups 10 COMMAND INPUTS and 11 REFERENCE SELECT (if drive operation is REM).</li> </ul>



Alarm Code	Display	Description
2009	DEVICE OVERTEMP	Drive heatsink is hot. This alarm warns that a DEVICE OVERTEMP fault may be near. R1...R4 & R7/R8: 100 °C (212 °F) R5/R6: 110 °C (230 °F) Check for and correct: <ul style="list-style-type: none"> <li>• Fan failure.</li> <li>• Obstructions in the air flow.</li> <li>• Dirt or dust coating on the heat sink.</li> <li>• Excessive ambient temperature.</li> <li>• Excessive motor load.</li> </ul>
2010	MOT OVERTEMP	Motor is hot, based on either the drive's estimate or on temperature feedback. This alarm warns that a Motor Underload fault trip may be near. Check: <ul style="list-style-type: none"> <li>• Check for overloaded motor.</li> <li>• Adjust the parameters used for the estimate (3005...3009).</li> <li>• Check the temperature sensors and Group 35 parameters.</li> </ul>
2011	UNDERLOAD	Motor load is lower than expected. This alarm warns that a Motor Underload fault trip may be near. Check: <ul style="list-style-type: none"> <li>• Motor and drive ratings match (motor is NOT undersized for the drive)</li> <li>• Settings on parameters 3013 to 3015</li> </ul>
2012	MOTOR STALL	Motor is operating in the stall region. This alarm warns that a Motor Stall fault trip may be near.
2013 (note 1)	AUTORESET	This alarm warns that the drive is about to perform an automatic fault reset, which may start the motor. <ul style="list-style-type: none"> <li>• To control automatic reset, use parameter group 31 AUTOMATIC RESET.</li> </ul>
2014 (note 1)	AUTOCHANGE	This alarm warns that the PFC autochange function is active. <ul style="list-style-type: none"> <li>• To control PFC, use parameter group 81 PFC CONTROL and "Application Macro: PFC" on page 49.</li> </ul>
2015	PFC INTERLOCK	This alarm warns that the PFC interlocks are active, which means that the drive cannot start the following: <ul style="list-style-type: none"> <li>• Any motor (when Autochange is used),</li> <li>• The speed regulated motor (when Autochange is not used).</li> </ul>
2016/ 2017	Reserved	
2018 (note 1)	PID SLEEP	This alarm warns that the PID sleep function is active, which means that the motor could accelerate when the PID sleep function ends. <ul style="list-style-type: none"> <li>• To control PID sleep, use parameters 4022...4026 or 4122...4126.</li> </ul>
2019	ID RUN	Performing ID Run.
2020	Reserved	
2021	START ENABLE 1 MISSING	This alarm warns that the Start Enable 1 signal is missing. <ul style="list-style-type: none"> <li>• To control Start Enable 1 function, use parameter 1608.</li> </ul> To correct, check: <ul style="list-style-type: none"> <li>• Digital input configuration.</li> <li>• Communication settings.</li> </ul>

Alarm Code	Display	Description
2022	START ENABLE 2 MISSING	This alarm warns that the Start Enable 2 signal is missing. <ul style="list-style-type: none"> <li>To control Start Enable 2 function, use parameter 1609.</li> </ul> To correct, check: <ul style="list-style-type: none"> <li>Digital input configuration.</li> <li>Communication settings.</li> </ul>
2023	EMERGENCY STOP	Emergency stop activated.
2024	ENCODER ERROR	The drive is not detecting a valid encoder signal. Check for and correct: <ul style="list-style-type: none"> <li>Encoder presence and proper connection (reverse wired, loose connection, or short circuit).</li> <li>Voltage logic levels are outside of the specified range.</li> <li>A working and properly connected Pulse Encoder Interface Module, OTAC-01.</li> <li>Wrong value entered in parameter 5001 PULSE NR. A wrong value will only be detected if the error is such that the calculated slip is greater than 4 times the rated slip of the motor.</li> <li>Encoder is not being used, but parameter 5002 ENCODER ENABLE = 1 (ENABLED).</li> </ul>
2025	FIRST START	Signals that a the drive is performing a First Start evaluation of motor characteristics. This is normal the first time the motor is run after motor parameters are entered or changed. See parameter 9910 (MOTOR ID RUN) for a description of motor models.

**Note 1.** Even when the relay output is configured to indicate alarm conditions (e.g. parameter 1401 RELAY OUTPUT 1 = 5 (ALARM) or 16 (FLT/ALARM)), this alarm is not indicated by a relay output.

### Alarm Codes (Basic Control Panel)

The Basic Control Panel indicates Control Panel alarms with a code, A5xxx. The following table lists the alarm codes and descriptions.

Code	Description
5001	Drive is not responding.
5002	The communication profile is incompatible with the drive.
5010	The panel's parameter backup file is corrupted.
5011	Drive is controlled from another source.
5012	Rotation direction is locked.
5013	Button is disabled, because start is inhibited.
5014	Button is disabled, because drive is faulted.
5015	Button is disabled, because local mode lock is on.
5018	Parameter default value can't be found.
5019	Writing a non-zero value is prohibited (can only write a zero value).
5020	Group or parameter does not exist or parameter value is inconsistent.
5021	Group or parameter is hidden.
5022	Group or parameter is write protected.
5023	Modification is not allowed while the drive is running.

<b>Code</b>	<b>Description</b>
5024	Drive is busy, try again.
5025	Write is not allowed while upload or download is in progress.
5026	Value is at or below low limit.
5027	Value is at or above high limit.
5028	Value is invalid – doesn't match any values in the discrete values list.
5029	Memory is not ready, try again.
5030	Request is invalid.
5031	Drive is not ready, e.g due to Low DC voltage.
5032	Parameter error was detected.
5040	Selected parameter set can't be found in the current parameter backup.
5041	Parameter backup doesn't fit into memory.
5042	Selected parameter set can't be found in the current parameter backup.
5043	No start inhibit was granted.
5044	Parameter backup versions do not match.
5050	Parameter upload was aborted.
5051	File error was detected.
5052	Parameter upload attempt has failed.
5060	Parameter download was aborted.
5062	Parameter download attempt has failed.
5070	Panel backup memory write error was detected.
5071	Panel backup memory read error was detected.
5080	Operation is not allowed, because the drive is not in local mode.
5081	Operation is not allowed, because a fault is active.
5082	Operation is not allowed, because override mode is enabled.
5083	Operation is not allowed, because parameter lock is not open.
5084	Operation is not allowed, because drive is busy, try again.
5085	Download is not allowed, because drive types are incompatible.
5086	Download is not allowed, because drive models are incompatible.
5087	Download is not allowed, because parameter sets do not match.
5088	Operation failed, because a drive memory error was detected.
5089	Download failed, because a CRC error was detected.
5090	Download failed, because a data processing error was detected.
5091	Operation failed, because a parameter error was detected.
5092	Download failed, because parameter sets do not match.

# Maintenance

---



**Warning! Read "Safety" on page 3 before performing any maintenance on the equipment. Ignoring the safety instructions can cause injury or death.**

---

## Maintenance Intervals

If installed in an appropriate environment, the drive requires very little maintenance. This table lists the routine maintenance intervals recommended by ABB.

Maintenance	Interval	Instruction
Heatsink temperature check and cleaning	Depends on the dustiness of the environment (every 6...12 months)	See "Heatsink" on page 212.
Main cooling fan replacement	Every five years	See "Main Fan Replacement" on page 213.
Internal enclosure cooling fan replacement (IP 54/UL Type 12 units)	Every three years.	See "Internal Enclosure Fan Replacement" on 214.
Capacitor change (Frame sizes R5 and R6)	Every ten years	See "Capacitors" on page 214.
Replace battery in the Assistant control panel	Every ten years	See "Battery" on page 215.

## Heatsink

The heatsink fins accumulate dust from the cooling air. Since a dusty heatsink is less efficient at cooling the drive, overtemperature faults become more likely. In a "normal" environment (not dusty, not clean) check the heatsink annually, in a dusty environment check more often.

Clean the heatsink as follows (when necessary):

1. Remove power from drive.
2. Remove the cooling fan (see section "Main Fan Replacement" on page 213).
3. Blow clean compressed air (not humid) from bottom to top and simultaneously use a vacuum cleaner at the air outlet to trap the dust.

---

**Note:** If there is a risk of the dust entering adjoining equipment, perform the cleaning in another room.

---

4. Replace the cooling fan.
5. Restore power.

## Main Fan Replacement

The drive's main cooling fan has a life span of about 60,000 operating hours at maximum rated operating temperature and drive load. The expected life span doubles for each 10 °C (18 °F) drop in the fan temperature (fan temperature is a function of ambient temperatures and drive loads).

Fan failure can be predicted by the increasing noise from fan bearings and the gradual rise in the heatsink temperature in spite of heatsink cleaning. If the drive is operated in a critical part of a process, fan replacement is recommended once these symptoms start appearing. Replacement fans are available from ABB. Do not use other than ABB specified spare parts.

### Frame Sizes R1...R4

To replace the fan:

1. Remove power from drive.
2. Remove drive cover.
3. For Frame Size:
  - R1, R2: Press together the retaining clips on the fan cover sides, and lift.
  - R3, R4: Press in on the lever located on the left side of the fan mount, and rotate the fan up and out.
4. Disconnect the fan cable.
5. Install the fan in reverse order.
6. Restore power.

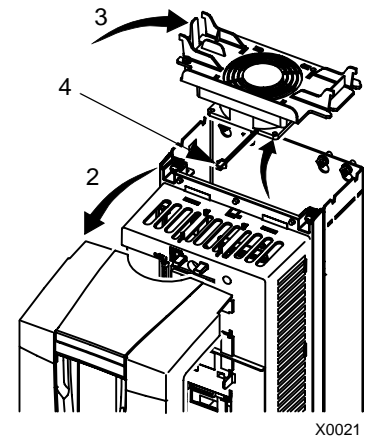

X0021

### Frame Sizes R5 and R6

To replace the fan:

1. Remove power from drive.
2. Remove the screws attaching the fan.
3. Remove the fan:
  - R5: Swing the fan out on its hinges.
  - R6: Pull the fan out.
4. Disconnect the fan cable.
5. Install the fan in reverse order.
6. Restore power.

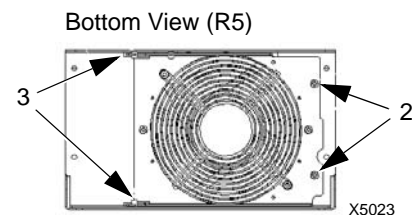

X5023

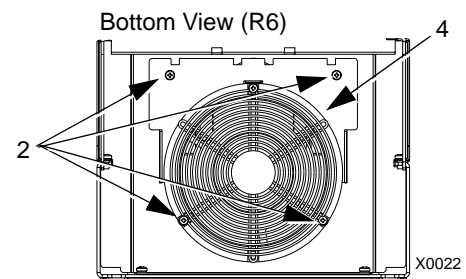

X0022

## Internal Enclosure Fan Replacement

IP 54 / UL Type 12 enclosures have an additional internal fan to circulate air inside the enclosure.

### Frame Sizes R1...R4

To replace the internal enclosure fan in frame sizes R1 to R4:

1. Remove power from drive.
2. Remove the front cover.
3. The housing that holds the fan in place has barbed retaining clips at each corner. Press all four clips toward the center to release the barbs.
4. When the clips/barbs are free, pull the housing up to remove from the drive.
5. Disconnect the fan cable.
6. Install the fan in reverse order, noting that:
  - The fan air flow is up (refer to arrow on fan).
  - The fan wire harness is toward the front.
  - The notched housing barb is located in the right-rear corner.
  - The fan cable connects just forward of the fan at the top of the drive.

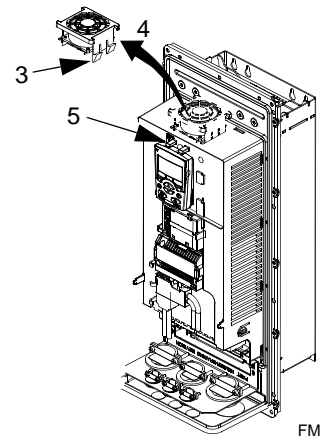

### Frame Sizes R5 and R6

To replace the internal enclosure fan in frame sizes R5 or R6:

- Remove power from drive.
- Remove the front cover.
- Lift the fan out and disconnect the cable.
- Install the fan in reverse order.
- Restore power.

## Capacitors

The drive intermediate circuit employs several electrolytic capacitors. Their life span is from 35,000...90,000 hours depending on drive loading and ambient temperature. Capacitor life can be prolonged by lowering the ambient temperature.

It is not possible to predict a capacitor failure. Capacitor failure is usually followed by a input power fuse failure or a fault trip. Contact ABB if capacitor failure is suspected. Replacements for frame size R5 and R6 are available from ABB. Do not use other than ABB specified spare parts.

## Control Panel

### Cleaning

Use a soft damp cloth to clean the control panel. Avoid harsh cleaners which could scratch the display window.

### Battery

A battery is only used in Assistant control panels that have the clock function available and enabled. The battery keeps the clock operating in memory during power interruptions.

The expected life for the battery is greater than ten years. To remove the battery, use a coin to rotate the battery holder on the back of the control panel. Replace the battery with type CR2032.

---

**Note!** The battery is NOT required for any control panel or drive function, except the clock.

---

# Technical Data

---

## Ratings

By type code, the table below provides ratings for the ACS550 adjustable speed AC drive, including:

- IEC ratings
- NEMA ratings (shaded columns)
- Frame size

### Ratings, 208...240 Volt Drives

Abbreviated column headers are described in "Symbols" on page 218.

Type Code	Normal Use			Heavy-Duty Use			Frame Size
ACS550-x1- see below	$I_{2N}$ A	$P_N$ kW	$P_N$ HP	$I_{2hd}$ A	$P_{hd}$ kW	$P_{hd}$ HP	
Three-phase supply voltage, 208...240 V							
-04A6-2	4.6	0.75	1.0	3.5	0.55	0.75	R1
-06A6-2	6.6	1.1	1.5	4.6	0.75	1.0	R1
-07A5-2	7.5	1.5	2.0	6.6	1.1	1.5	R1
-012A-2	11.8	2.2	3.0	7.5	1.5	2.0	R1
-017A-2	16.7	4.0	5.0	11.8	2.2	3.0	R1
-024A-2	24.2	5.5	7.5	16.7	4.0	5.0	R2
-031A-2	30.8	7.5	10.0	24.2	5.5	7.5	R2
-046A-2	46.2	11.0	15.0	30.8	7.5	10.0	R3
-059A-2	59.4	15.0	20.0	46.2	11.0	15.0	R3
-075A-2	74.8	18.5	25.0	59.4	15.0	20.0	R4
-088A-2	88.0	22.0	30.0	74.8	18.5	25.0	R4
-114A-2	114	30.0	40.0	88.0	22.0	30.0	R4
-143A-2	143	37.0	50.0	114	30.0	40.0	R6
-178A-2	178	45.0	60.0	150	37.0	50.0	R6
-221A-2	221	55.0	75.0	178	45.0	60.0	R6
-248A-2	248	75.0	100	192	55.0	75.0	R6



## Ratings, 380...480 Volt Drives

Abbreviated column headers are described in "Symbols" on page 218.

Type Code	Normal Use			Heavy-Duty Use			Frame Size
ACS550-x1- see below	$I_{2N}$ A	$P_N$ kW	$P_N$ HP	$I_{2hd}$ A	$P_{hd}$ kW	$P_{hd}$ HP	
Three-phase supply voltage, 380...480 V							
-03A3-4	3.3	1.1	1.5	2.4	0.75	1	R1
-04A1-4	4.1	1.5	2	3.3	1.1	1.5	R1
-05A4-4	5.4	2.2	Note 1	4.1	1.5	Note 1	R1
-06A9-4	6.9	3	3	5.4	2.2	2	R1
-08A8-4	8.8	4	5	6.9	3	3	R1
-012A-4	11.9	5.5	7.5	8.8	4	5	R1
-015A-4	15.4	7.5	10	11.9	5.5	7.5	R2
-023A-4	23	11	15	15.4	7.5	10	R2
-031A-4	31	15	20	23	11	15	R3
-038A-4	38	18.5	25	31	15	20	R3
-044A-4	44	22	30	38	18.5	25	R4
-059A-4	59	30	40	44	22	30	R4
-072A-4	72	37	50	59	30	40	R4
-077A-4 (Note 3)	77	Note 2	60	65	Note 2	50	R5
-078A-4 (Note 3)	77	Note 2	60	65	Note 2	50	R4
-096A-4	96	45	75	77	37	60	R5
-124A-4	124	55	100	96	45	75	R6
-157A-4	157	75	125	124	55	100	R6
-180A-4	180	90	150	156	75	125	R6
-195A-4	195	110	Note 1	162	90	Note 1	R6

1. Not available in ACS550-U1 series.
2. Not available in ACS550-01 series.
3. The ACS550-U1-078A-4 (an R4 frame size) replaces the ACS550-U1-077A-4 (discontinued in 2005).

## Ratings, 500...600 Volt Drives

Abbreviated column headers are described in "Symbols" on page 218.

Type Code ACS550-U1- see below	Normal Use			Heavy-Duty Use			Frame Size
	$I_{2N}$ A	$P_N$ kW	$P_N$ HP	$I_{2hd}$ A	$P_{hd}$ kW	$P_{hd}$ HP	
Three-phase supply voltage, 500...600 V (Note 1)							
-02A7-6	2.7	1.5	2	2.4	1.1	1.5	R2
-03A9-6	3.9	2.2	3	2.7	1.5	2.0	R2
-06A1-6	6.1	4.0	5	3.9	2.2	3.0	R2
-09A0-6	9	5.5	7.5	6.1	4.0	5.0	R2
-011A-6	11	7.5	10	9	5.5	7.5	R2
-017A-6	17	11.0	15	11	7.5	10	R2
-022A-6	22	15.0	20	17	11.0	15	R3
-027A-6	27	18.5	25	22	15.0	20	R3
-032A-6	32	22	30	27	18.5	25	R4
-041A-6	41	30	40	32	22	30	R4
-052A-6	52	37	50	41	30	40	R4
-062A-6	62	45	60	52	37	50	R4
-077A-6	77	55	75	62	45	60	R6
-099A-6	99	75	100	77	55	75	R6
-125A-6	125	90	125	99	75	100	R6
-144A-6	144	110	150	125	90	125	R6

1. Not available in ACS550-01 series.

## Symbols

### Typical ratings:

#### Normal use (10% overload capability)

$I_{2N}$  continuous rms current. 10% overload is allowed for one minute in ten minutes.

$P_N$  typical motor power in normal use. The kilowatt power ratings apply to most IEC, 4-pole motors. The Horsepower ratings apply to most 4-pole NEMA motors.

#### Heavy-duty use (50% overload capability)

$I_{2hd}$  continuous rms current. 50% overload is allowed for one minute in ten minutes.

$P_{hd}$  typical motor power in heavy duty use. The kilowatt power ratings apply to most IEC, 4-pole motors. The Horsepower ratings apply to most 4-pole NEMA motors.

## Sizing

The current ratings are the same regardless of the supply voltage within one voltage range. To achieve the rated motor power given in the table, the rated current of the drive must be higher than or equal to the rated motor current. Also note that:

- The ratings apply for ambient temperature of 40 °C (104 °F).
- The maximum allowed motor shaft power is limited to  $1.5 \cdot P_{hd}$ . If the limit is exceeded, motor torque and current are automatically restricted. The function protects the input bridge of the drive against overload.

## Derating

The load capacity (current and power) decreases for certain situations, as defined below. In such situations, where full motor power is required, oversize the drive so that the derated value provides sufficient capacity.

For example, if your application requires 15.4 A of motor current and a 8 kHz switching frequency, calculate the appropriate drive size requirement as follows:

The minimum size required =  $15.4 \text{ A} / 0.80 = 19.25 \text{ A}$

Where: 0.80 is the derating for 8 kHz switching frequency (see "Switching Frequency Derating" below).

Referring to  $I_{2N}$  in the ratings tables (page 216), the following drives exceed the  $I_{2N}$  requirement of 19.25 A: ACS550-x1-023A-4, or ACS550-x1-024A-2

### Temperature Derating

In the temperature range +40 °C...50 °C (+104 °F...122 °F) the rated output current is decreased 1% for every 1 °C (1.8 °F) above +40 °C (+104 °F). Calculate the output current by multiplying the current given in the rating table by the derating factor.

**Example** If the ambient temperature is 50 °C (+122 °F) the derating factor is  $100\% - 1\%/^{\circ}\text{C} \times 10^{\circ}\text{C} = 90\%$  or 0.90.

The output current is then  $0.90 \times I_{2N}$  or  $0.90 \times I_{2hd}$ .

### Altitude Derating

In altitudes from 1000...4000 m (3300...13,200 ft) above sea level, the derating is 1% for every 100 m (330 ft). If the installation site is higher than 2000 m (6600 ft) above sea level, please contact your local ABB distributor or office for further information.

### Single Phase Supply Derating

For 208...240 Volt series drives, a single phase supply can be used. In that case, the derating is 50%.

### Switching Frequency Derating

When using the 8 kHz switching frequency (parameter 2606), either:

- Derate  $P_N/P_{hd}$  and  $I_{2N}/I_{2hd}$  to 80% or
- Set parameter 2607 SW FREQ CTRL = 1 (ON) which allows the drive to reduce the switching frequency if/when the drive's internal temperature exceeds 90 °C. See the parameter description for 2607 for details.

When using the 12 kHz switching frequency (parameter 2606), either:

- Derate  $P_N/P_{hd}$  and  $I_{2N}/I_{2hd}$  to 65% (to 50% for 600 V, R4 frame sizes, that is for ACS550-U1-032A-6 ... ACS550-U1-062A-6), and derate ambient temperature maximum to 30 °C (86 °F), and note that the current is limited to a maximum value of  $I_{2hd}$ , or
- Set parameter 2607 SW FREQ CTRL = 1 (ON) which allows the drive to reduce the switching frequency if/when the drive's internal temperature exceeds 80 °C. See the parameter description for 2607 for details.

## Input Power Connections



**Warning! Do not operate the drive outside the nominal input line voltage range. Over-voltage can result in permanent damage to the drive.**

### Input Power Specifications

Input Power (Mains) Connection Specifications	
<b>Voltage (<math>U_1</math>)</b>	208/220/230/240 VAC 3-phase (or 1-phase) -15%...+10% for ACS550-x1-xxxx-2. 400/415/440/460/480 VAC 3-phase -15%...+10% for ACS550-x1-xxxx-4. 500/525/575/600 VAC 3-phase -15%...+10% for ACS550-U1-xxxx-6.
<b>Prospective short-circuit current (IEC 629)</b>	Maximum allowed prospective short-circuit current in the supply is 100 kA in a second providing that the mains cable of the drive is protected with appropriate fuses. US: 100,000 AIC.
<b>Frequency</b>	48...63 Hz
<b>Imbalance</b>	Max. $\pm$ 3% of nominal phase to phase input voltage
<b>Fundamental power factor (<math>\cos \phi_1</math>)</b>	0.98 (at nominal load)
<b>Cable Temperature Rating</b>	90 °C (194 °F) rating minimum.

### Disconnect Device

The ACS550 does not include a disconnect device. A means to disconnect input power must be installed between the AC power source and the ACS550. This disconnect device must:

- Be sized to conform to applicable safety regulations, including, but not limited to, both national and local electrical codes.
- Be locked in the open position during installation and maintenance work.

The disconnect device must not be used to control the motor. Instead use the control panel, or commands to the I/O terminals for motor control.

### Fuses

Branch circuit protection must be provided by the end-user, and sized per national and local electric codes. The following tables provide fuse recommendations for short circuit protection on the drive's input power.

## Fuses, 208...240 Volt Drives

ACS550-x1- see below	Input Current A	Mains Fuses		
		IEC269 gG (A)	UL Class T (A)	Bussmann Type
-04A6-2	4.6	10	10	JJS-10
-06A6-2	6.6			
-07A5-2	7.5			
-012A-2	11.8	16	15	JJS-15
-017A-2	16.7	25	25	JJS-25
-024A-2	24.2		30	JJS-30
-031A-2	30.8	40	40	JJS-40
-046A-2	46.2	63	60	JJS-60
-059A-2	59.4		80	JJS-80
-075A-2	74.8	80	100	JJS-100
-088A-2	88.0	100	110	JJS-110
-114A-2	114	125	150	JJS-150
-143A-2	143	200	200	JJS-200
-178A-2	178	250	250	JJS-250
-221A-2	221	315	300	JJS-300
-248A-2	248		350	JJS-350

## Fuses, 380...480 Volt Drives

ACS550-x1- see below	Input Current A	Mains Fuses		
		IEC269 gG (A)	UL Class T (A)	Bussmann Type
-03A3-4	3.3	10	10	JJS-10
-04A1-4	4.1			
-05A4-4	5.4			
-06A9-4	6.9			
-08A8-4	8.8	16	15	JJS-15
-012A-4	11.9		20	JJS-20
-015A-4	15.4			
-023A-4	23	25	30	JJS-30
-031A-4	31	35	40	JJS-40
-038A-4	38	50	50	JJS-50
-044A-4	44		60	JJS-60
-059A-4	59	63	80	JJS-80
-072A-4	72	80	90	JJS-90
-077A-4	77		100	JJS-100
-078A-4	77		100	JJS-100
-096A-4	96	125	125	JJS-125
-124A-4	124	160	175	JJS-175
-157A-4	157	200	200	JJS-200
-180A-4	180	250	250	JJS-250
-195A-4	195	250	250	JJS-250

## Fuses, 500...600 Volt Drives

ACS550-U1- see below	Input Current A	Mains Fuses		
		IEC269 gG (A)	UL Class T (A)	Bussmann Type
-02A7-6	2.7	10	10	JJS-10
-03A9-6	3.9			
-06A1-6	6.1			
-09A0-6	9	16	15	JJS-15
-011A-6	11			
-017A-6	17	25	25	JJS-25
-022A-6	22			
-027A-6	27	35	40	JJS-40
-032A-6	32			
-041A-6	41	50	50	JJS-50
-052A-6	52	60	60	JJS-60
-062A-6	62	80	80	JJS-80
-077A-6	77		100	JJS-100
-099A-6	99	125	150	JJS-150
-125A-6	125	160	175	JJS-175
-144A-6	144	200	200	JJS-200

**Emergency Stop Devices**

The overall design of the installation must include emergency stop devices and any other safety equipment that may be needed. Pressing STOP on the drive's control panel does NOT:

- Generate an emergency stop of the motor.
- Separate the drive from dangerous potential.

**Input Power Cables/ Wiring**

Input wiring can be any of:

- A four conductor cable (three phases and ground/protective earth). Shielding is not required.
- Four insulated conductors routed through conduit.

Size wiring according to local safety regulations, appropriate input voltage and the drive's load current. In any case, the conductor must be less than the maximum limit defined by the terminal size (see "Drive's Power Connection Terminals" on page 225).

The table below lists copper and aluminum cable types for different load currents. These recommendations apply only for the conditions listed at the top of the table.

IEC				NEC	
Based on:				Based on:	
<ul style="list-style-type: none"> <li>EN 60204-1 and IEC 60364-5-2/2001</li> <li>PVC insulation</li> <li>30 °C (86 °F) ambient temperature</li> <li>70 °C (158 °F) surface temperature</li> <li>Cables with concentric copper shield</li> <li>Not more than nine cables laid on cable ladder side by side.</li> </ul>				<ul style="list-style-type: none"> <li>NEC Table 310-16 for copper wires</li> <li>90 °C (194 °F) wire insulation</li> <li>40 °C (104 °F) ambient temperature</li> <li>Not more than three current-carrying conductors in raceway or cable, or earth (directly buried).</li> <li>Copper cables with concentric copper shield</li> </ul>	
Max Load Current (A)	Cu Cable (mm <sup>2</sup> )	Max Load Current (A)	Al Cable (mm <sup>2</sup> )	Max Load Current (A)	Cu Wire Size (AWG/kcmil)
14	3x1.5	Do not use aluminum cable with frame sizes R1...R4		22.8	14
20	3x2.5			27.3	12
27	3x4			36.4	10
34	3x6			50.1	8
47	3x10			68.3	6
62	3x16			86.5	4
79	3x25			100	3
98	3x35			91	3x50
119	3x50	117	3x70	137	1
153	3x70	143	3x95	155	1/0
186	3x95	165	3x120	178	2/0
215	3x120	191	3x150	205	3/0
249	3x150	218	3x185	237	4/0
284	3x185	257	3x240	264	250 MCM or 2 x 1
		274	3x (3x50)	291	300 MCM or 2 x 1/0
		285	2x (3x95)	319	350 MCM or 2 x 2/0

### Ground Connections

For personnel safety, proper operation and to reduce electromagnetic emission/pick-up, the drive and the motor must be grounded at the installation site.

- Conductors must be adequately sized as required by safety regulations.
- Power cable shields must be connected to the drive PE terminal in order to meet safety regulations.
- Power cable shields are suitable for use as equipment grounding conductors only when the shield conductors are adequately sized as required by safety regulations.
- In multiple drive installations, do not connect drive terminals in series.

*Unsymmetrically Grounded Networks*



**Warning! Do not attempt to install or remove EM1 or EM3 screws while power is applied to the drive's input terminals.**

Unsymmetrically grounded networks are defined in the following table. In such networks, the internal connection provided by the EM3 screw (on frame sizes R1...R4 only) must be disconnected by removing EM3. If the grounding configuration of the network is unknown, remove EM3. Note that:

- ACS550-01 drives are shipped with the screw installed.
- ACS550-U1 drives are shipped with the screw removed (but included in the conduit box).

Unsymmetrically Grounded Networks – EM3 Must Be Out			
Grounded at the corner of the delta		Grounded at the mid point of a delta leg	
Single phase, grounded at an end point		Three phase "Variac" without solidly grounded neutral	

EM3 (an M4x16 screw) makes an internal ground connection that reduces electro-magnetic emission. Where EMC (electro-magnetic compatibility) is a concern, and the network is symmetrically grounded, EM3 may be installed. For reference, the diagram at right illustrates a symmetrically grounded network.

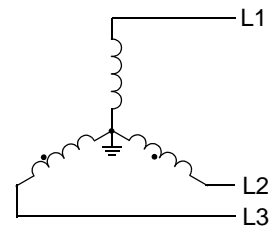

*Floating Networks*



**Warning! Do not attempt to install or remove EM1, EM3, F1 or F2 screws while power is applied to the drive's input terminals.**

For floating networks (also known as IT, ungrounded, or impedance/resistance grounded networks):

- Disconnect the ground connection to the internal RFI filters:
  - ACS550-01, frame sizes R1...R4: Remove both the EM1 and EM3 screws (see "Power Connection Diagrams" on page 15).



- ACS550-U1, frame sizes R1...R4: Remove the EM1 screw (unit is shipped with EM3 removed, see "Power Connection Diagrams" on page 15).
- Frame sizes R5...R6: Remove both the F1 and F2 screws (see page 16).
- Where EMC requirements exist, check for excessive emission propagated to neighboring low voltage networks. In some cases, the natural suppression in transformers and cables is sufficient. If in doubt, use a supply transformer with static screening between the primary and secondary windings.
- Do NOT install an external RFI/EMC filter, such as one of the kits listed in "EN 61800-3 Compliant Motor Cables" on page 229. Using an RFI filter grounds the input power through the filter capacitors, which could be dangerous and could damage the unit.

### Drive's Power Connection Terminals

The following table provides specifications for the drive's power connection terminals.

Frame Size	U1, V1, W1 U2, V2, W2 BRK±, UDC± Terminals						Earthing PE Terminal			
	Min. Wire Size		Max. Wire Size		Torque		Max. Wire Size		Torque	
	mm <sup>2</sup>	AWG	mm <sup>2</sup>	AWG	Nm	lb-ft	mm <sup>2</sup>	AWG	Nm	lb-ft
R1 <sup>1</sup>	0.75	18	16	6	1.3	1	16	6	1.3	1
R2 <sup>1</sup>	0.75	18	16	6	1.3	1	16	6	1.3	1
R3 <sup>1</sup>	2.5	14	25	3	2.7	2	25	3	2.7	2
R4 <sup>1</sup>	10	8	50	1/0	5.6	4	50	1/0	5.6	4
R5	16	6	70	2/0	15	11	70	2/0	15	11
R6	95	3/0	185	350 MCM	40	30	185	350 MCM	40	30

1. Do not use aluminum cable with frame sizes R1...R4.

### Power Terminal Considerations – R6 Frame Size



**Warning! For R6 power terminals, if compression lugs are supplied, they can only be used for wire sizes that are 95 mm<sup>2</sup> (3/0 AWG) or larger. Smaller wires will loosen and may damage the drive, and require ring lugs as described below.**

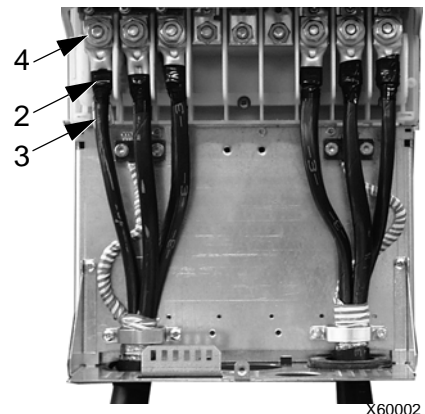

### Ring Lugs

On the R6 frame size, if the cable size used is less than 95 mm<sup>2</sup> (3/0 AWG) or if no compression lugs are supplied, use ring lugs according to the following procedure.

1. Select appropriate ring lugs from the following table.
2. Attach the supplied terminal lugs to the drive end of the cables.
3. Isolate the ends of the ring lugs with insulating tape or shrink tubing.

## 4. Attach terminal lug to the drive.

Wire Size		Manufacturer	Ring Lug	Crimping Tool	No. of Crimps
mm <sup>2</sup>	kcmil/ AWG				
16	6	Burndy	YAV6C-L2	MY29-3	1
		IlSCO	CCL-6-38	ILC-10	2
25	4	Burndy	YA4C-L4BOX	MY29-3	1
		IlSCO	CCL-4-38	MT-25	1
35	2	Burndy	YA2C-L4BOX	MY29-3	2
		IlSCO	CRC-2	IDT-12	1
		IlSCO	CCL-2-38	MT-25	1
50	1	Burndy	YA1C-L4BOX	MY29-3	2
		IlSCO	CRA-1-38	IDT-12	1
		IlSCO	CCL-1-38	MT-25	1
		Thomas & Betts	54148	TBM-8	3
55	1/0	Burndy	YA25-L4BOX	MY29-3	2
		IlSCO	CRB-0	IDT-12	1
		IlSCO	CCL-1/0-38	MT-25	1
		Thomas & Betts	54109	TBM-8	3
70	2/0	Burndy	YAL26T38	MY29-3	2
		IlSCO	CRA-2/0	IDT-12	1
		IlSCO	CCL-2/0-38	MT-25	1
		Thomas & Betts	54110	TBM-8	3
95	3/0	Burndy	YAL27T38	MY29-3	2
		IlSCO	CRA-3/0	IDT-12	1
		IlSCO	CCL-3/0-38	MT-25	1
		Thomas & Betts	54111	TBM-8	3
95	3/0	Burndy	YA28R4	MY29-3	2
		IlSCO	CRA-4/0	IDT-12	1
		IlSCO	CCL-4/0-38	MT-25	2
		Thomas & Betts	54112	TBM-8	4

*Compression Lugs*

Use the following procedure to attach cables if compression lugs are supplied and can be used.

1. Attach the supplied compression lugs to the drive end of the cables.
2. Attach compression lug to the drive.

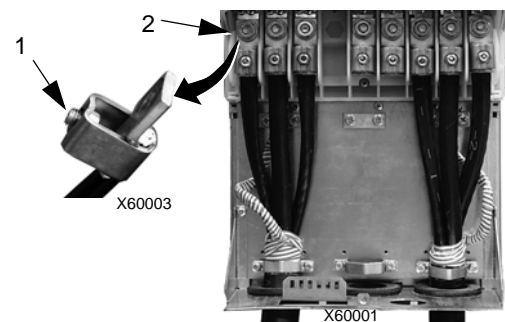

## Motor Connections



**Warning! Never connect line power to the drive output terminals: U2, V2 or W2. Line voltage applied to the output can result in permanent damage to the unit. If frequent bypassing is required, use mechanically interlocked switches or contactors.**



**Warning! Do not connect any motor with a nominal voltage less than one half of the drive's nominal input voltage.**



**Warning! Disconnect the drive before conducting any voltage tolerance (Hi-Pot) test or insulation resistance (Megger) test on the motor or motor cables. Do not conduct these tests on the drive.**

### Motor Connection Specifications

Motor Connection Specifications					
<b>Voltage (<math>U_2</math>)</b>	0... $U_1$ , 3-phase symmetrical, $U_{max}$ at the field weakening point				
<b>Frequency</b>	0...500 Hz				
<b>Frequency Resolution</b>	0.01 Hz				
<b>Current</b>	See "Ratings" on page 216.				
<b>Field Weakening Point</b>	10...500 Hz				
<b>Switching Frequency</b>	Selectable: 1, 4, 8, or 12 kHz (1, 4, or 8 kHz for 600 V, R6 frame size, that is for ACS550-U1-077A-6 ... ACS550-U1-144A-6)				
<b>Cable Temperature Rating</b>	90 °C (194 °F) rating minimum.				
<b>Maximum Motor Cable Length</b>	<b>Frame Size</b>	<b>Max. Motor Cable Length*</b>			
		<b><math>f_{sw} = 1</math> or 4 kHz</b>		<b><math>f_{sw} = 8</math> kHz or 12 kHz</b>	
	R1	100 m	330 ft	100 m	330 ft
	R2 (most)	200 m	650 ft	100 m	330 ft
	R2 (600 V)	100 m	330 ft	100 m	330 ft
	R3...R4	200 m	650 ft	100 m	330 ft
R5...R6	300 m	980 ft	150 m	490 ft	



**\* Warning! Using a motor cable longer than specified in the chart above may cause permanent damage to the drive.**

### Ground Fault Protection

ACS550 internal fault logic detects ground faults in the drive, motor, or motor cable. This fault logic:

- Is NOT a personal safety or fire protection feature.
- Can be disabled using parameter 3017 EARTH FAULT.

- Could be tripped by leakage currents (input power to ground) associated with long high capacitance motor cables.

## Grounding and Routing

### Motor Cable Shielding

Motor cables require shielding using conduit, armored cable or shielded cable.

- Conduit – When using conduit:
  - Bridge joints with a ground conductor bonded to the conduit on each side of the joint.
  - Bond conduit run to the drive enclosure.
  - Use a separate conduit run for motor cables (also separate input power and control cables).
  - Use a separate conduit run for each drive.
- Armored Cable – When using armored cable:
  - Use six-conductor (3 phases and 3 grounds), type MC continuous corrugated aluminum armor cable with symmetrical grounds.
  - Armored motor cable can share a cable tray with input power cables, but not with control cables.
- Shielded Cable – For shielded cable details, see "Motor Cable Requirements for CE & C-Tick Compliance" below.

### Grounding

See "Ground Connections" in "Input Power Connections" above.

For CE compliant installations and installations where EMC emissions must be minimized, see "Effective Motor Cable Screens" below.

## Drive's Motor Connection Terminals

The drive's motor and input power terminals have the same specifications. See "Drive's Power Connection Terminals" above.

## Motor Cable Requirements for CE & C-Tick Compliance

The requirements in this section apply for CE or C-Tick compliance.

### Minimum Requirement (CE & C-Tick)

The motor cable must be a symmetrical three conductor cable with a concentric PE conductor or a four conductor cable with a concentric shield, however, a symmetrical constructed PE conductor is always recommended. The following figure shows the minimum requirement for the motor cable screen (for example, MCMK, NK Cables).

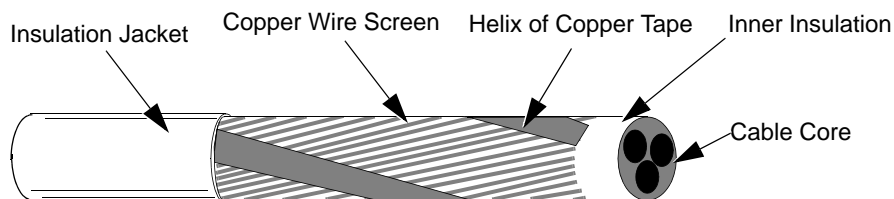

### Recommendation for Conductor Layout

The following figure compares conductor layout features in motor cables.

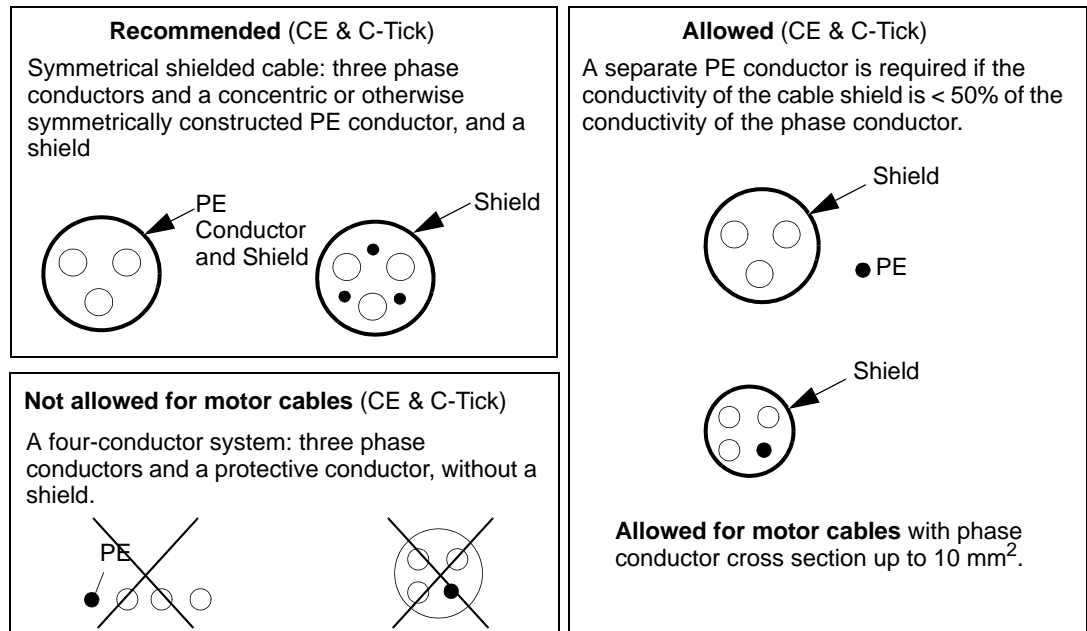

### Effective Motor Cable Screens

The general rule for cable screen effectiveness is: the better and tighter the cable's screen, the lower the radiated emission level. The following figure shows an example of an effective construction (for example Ölflex-Servo-FD 780 CP, Lappkabel or MCCMK, NK Cables).

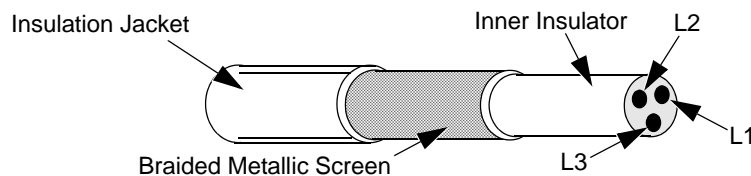

### EN 61800-3 Compliant Motor Cables

To comply with EN 61800-3 requirements:

- Motor cables must have an effective screen as described in "Effective Motor Cable Screens" on page 229.
- Motor cable screen wires must be twisted together into a bundle (the bundle length must be less than five times its width) and connected to the terminal marked  $\perp$  (at the bottom right-hand corner of the drive).
- Motor cables must be grounded, at the motor end, with an EMC cable gland. The ground must contact the cable screen all the way around the cable.

- For EN 61800-3 First Environment, Restricted Distribution (CISPR11 Class A), and EN 61800-3 Second Environment compliance, the drive includes an internal filter that provides compliance for at least 30 m (100 ft.) motor cable lengths. For some drives, longer cable lengths require an additional, external RFI/EMC filter as specified in the table below. The RFI/EMC filters are separate options and installation must conform to the instructions in the filter package for all cable screen connections.

Maximum Cable Length for EN 61800-3 First Environment, Restricted Distribution (CISPR11 Class A) Compliance (Radiated and Conducted Emissions)					
Drive Type		Switching Frequency (Parameter 2606)			
		1 or 4 kHz (2606 = 1 or 4)		8 kHz (2606 = 8)	
		Max. Length / Internal Filter	Max. Length / RFI/EMC Filter	Max. Length / Internal Filter	Max. Length / RFI/EMC Filter
ACS550-x1-03A3-4	R1	100 m (330 ft) / Internal	Note 1	100 m (330 ft) / Internal	Note 1
ACS550-x1-04A1-4					
ACS550-x1-06A9-4					
ACS550-x1-08A8-4					
ACS550-x1-012A-4					
ACS550-x1-015A-4	R2	30 m (100 ft) / Internal	100 m (330 ft) / ACS400-IF21-3	30 m (100 ft) / Internal	100 m (330 ft) / ACS400-IF21-3
ACS550-x1-023A-4					
ACS550-x1-031A-4	R3	30 m (100 ft) / Internal	100 m (330 ft) / ACS400-IF31-3	30 m (100 ft) / Internal	100 m (330 ft) / ACS400-IF31-3
ACS550-x1-038A-4					
ACS550-x1-044A-4	R4	30 m (100 ft) / Internal	100 m (330 ft) / ACS400-IF41-3	30 m (100 ft) / Internal	100 m (330 ft) / ACS400-IF41-3
ACS550-x1-059A-4					
ACS550-x1-072A-4					
ACS550-U1-078A-4			Note 2		Note 2
ACS550-U1-077A-4	R5	100 m (330 ft) / Internal	Note 1	100 m (330 ft) / Internal	Note 1
ACS550-x1-096A-4					
ACS550-x1-124A-4	R6	100 m (330 ft) / Internal	Note 1	Note 2	Note 2
ACS550-x1-157A-4					
ACS550-x1-180A-4					
ACS550-x1-195A-4					

- For any motor cable length (up to the 100 m maximum length limit) compliance does not require an additional filter.
- Data not available at time of publication.



**Warning! Do not use RFI/EMC filters in a floating, or impedance grounded network.**

- For EN 61800-3 First Environment, Unrestricted Distribution, (CISPR11 Class B) compliance with conducted emission limits, all drives require an additional, external RFI/EMC filter, and cable lengths are limited as specified in the table below. The RFI/EMC filters are separate options and installation must conform to the instructions in the filter package for all cable screen connections.

**Note!** The filter does not assure compliance with radiated emissions limits.

Maximum Cable Length for EN 61800-3 CE First Environment, Unrestricted Distribution (CISPR11 Class B) Compliance (Conducted Emissions Only)			
Drive Type		Switching Frequency (Parameter 2606)	
		1 or 4 kHz (2606 = 1 or 4)	8 kHz (2606 = 8)
		Max. Length / RFI/EMC Filter	Max. Length / RFI/EMC Filter
ACS550-x1-03A3-4	R1	10 m (33 ft) / ACS400-IF11-3	10 m (33 ft) / ACS400-IF11-3
ACS550-x1-04A1-4			
ACS550-x1-06A9-4			
ACS550-x1-08A8-4			
ACS550-x1-012A-4			
ACS550-x1-015A-4	R2	10 m (33 ft) / ACS400-IF21-3	10 m (33 ft) / ACS400-IF21-3
ACS550-x1-023A-4			
ACS550-x1-031A-4	R3	10 m (33 ft) / ACS400-IF31-3	10 m (33 ft) / ACS400-IF31-3
ACS550-x1-038A-4			
ACS550-x1-044A-4	R4	10 m (33 ft) / ACS400-IF41-3	10 m (33 ft) / ACS400-IF41-3
ACS550-x1-059A-4			
ACS550-x1-072A-4			



**Warning! Do not use RFI/EMC filters in a floating, or impedance grounded network.**

## Brake Components

### Availability

Braking availability for ACS550 drives, by frame size is:

- R1 and R2 – a built-in brake chopper is standard equipment. Add appropriate resistor, as determined using the following section. Resistors are available from ABB.
- R3...R6 – does not include an internal brake chopper. Connect a chopper and a resistor, or a brake unit to the DC link terminals on the drive. Contact your ABB representative for appropriate parts.

### Selecting the Braking Resistors (Frame Sizes R1 and R2)

Braking resistor must meet three requirements:

- Resistance must be always higher than the minimum value  $R_{MIN}$  defined for the drive type in the following tables. Never use resistance below this value.
- Resistance must be low enough to be able to produce the desired braking torque. To achieve the maximum braking torque (the larger of 150% of heavy duty or 110% of nominal duty), the resistance must not exceed  $R_{MAX}$ . If maximum braking torque is not necessary, resistor values can exceed  $R_{MAX}$ .
- The resistor power rating must be high enough to dissipate the braking power. This requirement involves many factors:
  - The maximum continuous power rating for the resistor(s).
  - The rate at which the resistor changes temperature (resistor thermal time constant).
  - Maximum braking time ON – If the regeneration (braking) power is larger than the resistor rated power, there is a limit to the ON time, or the resistor overheats before the OFF period begins.
  - Minimum braking time OFF – If the regeneration (braking) power is larger than the resistor rated power, the OFF time must be large enough for the resistor to cool between ON periods.

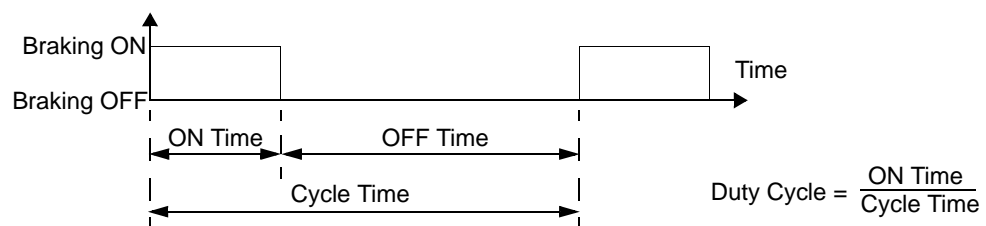

- The peak braking power requirement.
- Type of braking (deceleration to zero vs. overhauling load) – During deceleration to zero, the generated power steadily decreases, averaging half of the peak power. For an overhauling load, the braking is countering an external force (gravity for example) and the braking power is constant. The total heat generated from an overhauling load is double the heat generated from deceleration to zero speed (for the same peak torque and ON time).



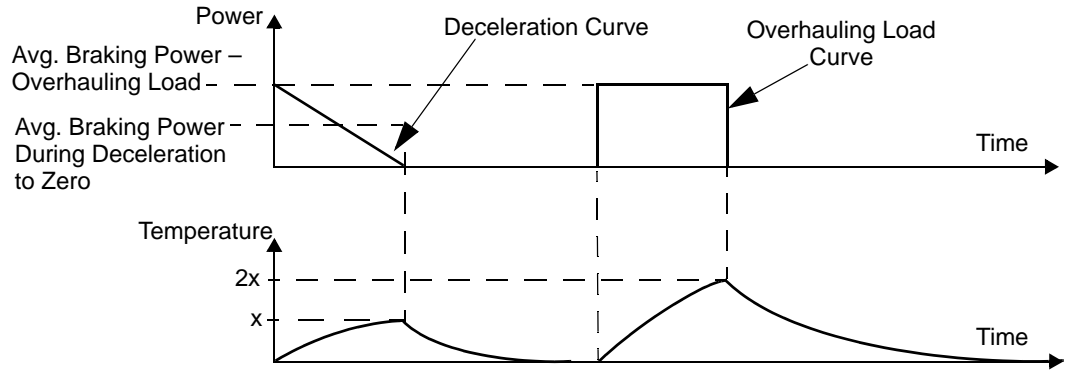

The many variables in the last requirement above are most easily dealt with using the following tables.

- First, determine your maximum braking time ON ( $ON_{MAX}$ ), minimum braking time OFF ( $OFF_{MIN}$ ) and load type (deceleration or overhauling load).
- Calculate duty cycle:

$$\text{Duty Cycle} = \frac{ON_{MAX}}{(ON_{MAX} + OFF_{MIN})} \times 100\%$$

- In the appropriate table, find the column that best matches your data:
  - $ON_{MAX} \leq$  column specification and
  - Duty Cycle  $\leq$  column specification
- Find the row that matches your drive.
- The minimum power rating for deceleration to zero is the value in the selected row/column.
- For overhauling loads, double the rating in the selected row/column, or use the Continuous ON column.

**208...240 Volt Drives**

Type Code ACS550-01/U1-see below	Resistance		Resistor <sup>1</sup> Minimum Continuous Power Rating				
	$R_{MAX}$	$R_{MIN}$	Deceleration-to-Zero Rating				$P_{rcont}$ Continuous ON > 60 s ON > 25% Duty
			$P_{r3}$ ≤ 3 s ON ≥ 27 s OFF ≤ 10% Duty	$P_{r10}$ ≤ 10 s ON ≥ 50 s OFF ≤ 17% Duty	$P_{r30}$ ≤ 30 s ON ≥ 180 s OFF ≤ 14% Duty	$P_{r60}$ ≤ 60 s ON ≥ 180 s OFF ≤ 25% Duty	
Ohm	Ohm	W	W	W	W	W	
Three-phase supply voltage, 208...240 V							
-04A6-2	234	80	45	80	120	200	1100
-06A6-2	160	80	65	120	175	280	1500
-07A5-2	117	44	85	160	235	390	2200
-012A-2	80	44	125	235	345	570	3000
-017A-2	48	44	210	390	575	950	4000
-024A-2	32	30	315	590	860	1425	5500
-031A-2	23	22	430	800	1175	1940	7500

1. Resistor time constant specification must be  $\geq$  85 seconds.

## 380...480 Volt Drives

Type Code ACS550- 01/U1- see below	Resistance		Resistor <sup>1</sup> Minimum Continuous Power Rating				
	R <sub>MAX</sub>	R <sub>MIN</sub>	Deceleration-to-Zero Rating				P <sub>rcont</sub> Continuous ON > 60 s ON > 25% Duty
			P <sub>r3</sub> ≤ 3 s ON ≥ 27 s OFF ≤ 10% Duty	P <sub>r10</sub> ≤ 10 s ON ≥ 50 s OFF ≤ 17% Duty	P <sub>r30</sub> ≤ 30 s ON ≥ 180 s OFF ≤ 14% Duty	P <sub>r60</sub> ≤ 60 s ON ≥ 180 s OFF ≤ 25% Duty	
Ohm	Ohm	W	W	W	W	W	
Three-phase supply voltage, 380...480 V							
-03A3-4	641	120	65	120	175	285	1100
-04A1-4	470	120	90	160	235	390	1500
-05A4-4	320	120	125	235	345	570	2200
-06A9-4	235	80	170	320	470	775	3000
-08A8-4	192	80	210	400	575	950	4000
-012A-4	128	80	315	590	860	1425	5500
-015A-4	94	63	425	800	1175	1950	7500
-023A-4	64	63	625	1175	1725	2850	11000

1. Resistor time constant specification must be ≥ 85 seconds.

## 500...600 Volt Drives

Type Code ACS550- U1- see below	Resistance		Resistor <sup>1</sup> Minimum Continuous Power Rating				
	R <sub>MAX</sub>	R <sub>MIN</sub>	Deceleration-to-Zero Rating				P <sub>rcont</sub> Continuous ON > 60 s ON > 25% Duty
			P <sub>r3</sub> ≤ 3 s ON ≥ 27 s OFF ≤ 10% Duty	P <sub>r10</sub> ≤ 10 s ON ≥ 50 s OFF ≤ 17% Duty	P <sub>r30</sub> ≤ 30 s ON ≥ 180 s OFF ≤ 14% Duty	P <sub>r60</sub> ≤ 60 s ON ≥ 180 s OFF ≤ 25% Duty	
Ohm	Ohm	W	W	W	W	W	
Three-phase supply voltage, 500...600 V							
-02A7-6	548	80	93	175	257	425	1462
-03A9-6	373	80	137	257	377	624	2144
-06A1-6	224	80	228	429	629	1040	3573
-09A0-6	149	80	342	643	943	1560	5359
-011A-6	110	60	467	877	1286	2127	7308
-017A-6	75	60	685	1286	1886	3119	10718

1. Resistor time constant specification must be ≥ 85 seconds.



**WARNING! Never use a brake resistor with a resistance below the minimum value specified for the particular drive. The drive and the internal chopper are not able to handle the overcurrent caused by the low resistance.**

### Symbols

**R<sub>MIN</sub>** – Minimum allowed braking resistor.

**R<sub>MAX</sub>** – Maximum resistance allowed if maximum braking torque is necessary.

$P_{rx}$  – Duty-cycle based resistor power rating in deceleration braking, where “x” is  $ON_{MAX}$  time.

### Installing and Wiring Resistors

All resistors must be installed outside the drive module in a place where they can dissipate heat.



**Warning! The surface temperature of the resistor is very high and air flowing from the resistor is very hot. Materials near the brake resistor must be non-flammable. Provide protection from accidental contact with the resistor.**

To ensure that the input fuses protect the resistor cable, use resistor cables with the same rating as used for the power input to the drive.

The maximum length of the resistor cable(s) is 10 m (33 ft). See the "Power Connection Diagrams" on page 15 for the resistor cable connection points.

### Mandatory Circuit Protection

The following setup is essential for safety – it interrupts the main supply in fault situations involving chopper shorts:

- Equip the drive with a main contactor.
- Wire the contactor so that it opens if the resistor thermal switch opens (an overheated resistor opens the contactor).

Below is a simple wiring diagram example.

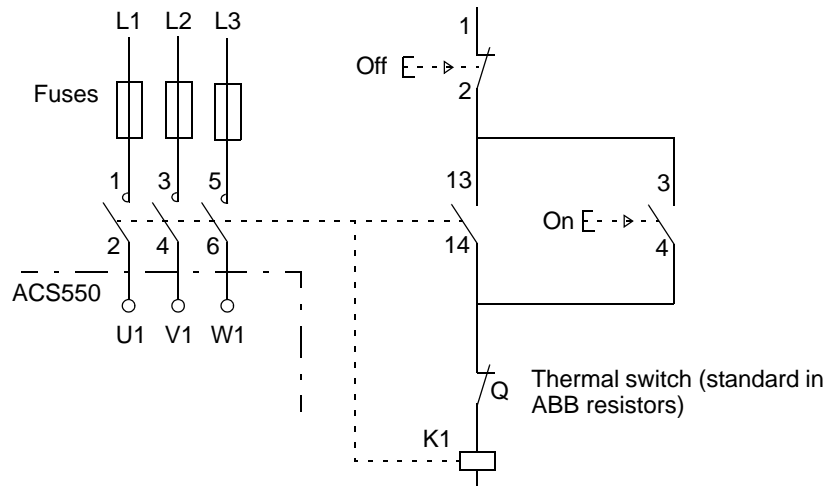

### Parameter Set-up

To enable dynamic braking, switch off the drive's overvoltage control (Set parameter 2005 = 0 (DISABLE))

## Control Connections

### Control Connection Specifications

Control Connection Specifications	
<b>Analog Inputs and Outputs</b>	See table heading "Hardware Description" on page 17.
<b>Digital Inputs</b>	Digital input impedance 1.5 k $\Omega$ . Maximum voltage for digital inputs is 30 V.
<b>Relays (Digital Outputs)</b>	<ul style="list-style-type: none"> <li>• Max. contact voltage: 30 V DC, 250 V AC</li> <li>• Max. contact current / power: 6 A, 30 V DC; 1500 VA, 250 V AC</li> <li>• Max. continuous current: 2 A rms (<math>\cos \varphi = 1</math>), 1 A rms (<math>\cos \varphi = 0.4</math>)</li> <li>• Minimum load: 500 mW (12 V, 10 mA)</li> <li>• Contact material: Silver-nickel (AgN)</li> <li>• Isolation between relay digital outputs, test voltage: 2.5 kV rms, 1 minute</li> </ul>
<b>Cable Specifications</b>	See "Control Terminals Table" on page 17.

### Control Cables

#### General Recommendations

Use multi-core cables with a braided copper wire screen, temperature rated at 60 °C (140 °F) or above:

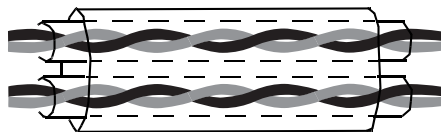

Double Shielded  
Example: JAMAK by Draka NK Cables

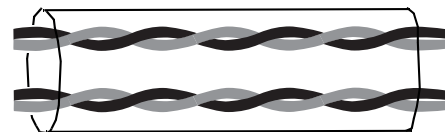

Single Shielded  
Example: NOMAK by Draka NK Cables

At the drive end, twist the screen together into a bundle not longer than five times its width and connected to terminal X1-1 (for digital and analog I/O cables) or to either X1-28 or X1-32 (for RS485 cables). Leave the other end of the cable shield unconnected.

Route control cables to minimize radiation to the cable:

- Route as far away as possible from the input power and motor cables (at least 20 cm (8 in)).
- Where control cables must cross power cables make sure they are at an angle as near 90° as possible.
- Stay at least 20 cm (8 in) from the sides of the drive.

Use care in mixing signal types on the same cable:

- Do not mix analog and digital input signals on the same cable.
- Run relay-controlled signals as twisted pairs (especially if voltage > 48 V). Relay-controlled signals using less than 48 V can be run in the same cables as digital input signals.

---

**Note!** Never mix 24 VDC and 115/230 VAC signals in the same cable.

---

**Note!** Triacs used as sources for drive inputs, may have excessive leakage current in the OFF state, enough to read as ON to drive inputs. Driving two or more inputs, divides the leakage current, reducing or eliminating the problem. An alternative is to add a small capacitive load – see figure.

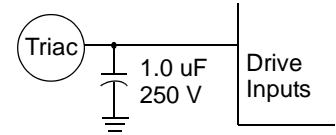

**WARNING!** Relay coils generate noise spikes in response to steps in applied power. To avoid drive damage from such spikes, all AC relay coils mounted across drive inputs require R-C snubbers, and all DC relay coils mounted across drive outputs require diodes – see figure.

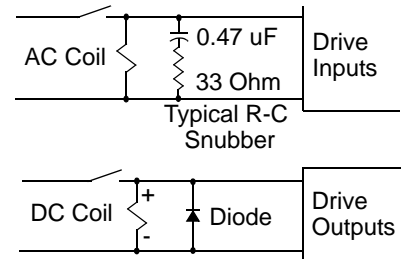

*Analog Cables*

Recommendations for analog signal runs:

- Use double shielded, twisted pair cable.
- Use one individually shielded pair for each signal.
- Do not use a common return for different analog signals.

*Digital Cables*

Recommendation for digital signal runs: A double shielded cable is the best alternative, but single-shielded, twisted, multi-pair cable is also usable.

*Control Panel Cable*

If the control panel is connected to the drive with a cable, use only Category 5 Patch ethernet cable. The maximum length that is tested to meet EMC specifications is 3 m (9.8 ft). Longer cables are susceptible to electromagnetic noise and must be user-tested to verify that EMC requirements are met. Where long runs are required (especially for runs longer than about 12 m (40 ft)), use a RS232/RS485 converter at each end and run RS485 cable.

**Drive's Control Connection Terminals**

The following table provides specifications for the drive's control terminals

Frame Size	Control			
	Maximum Wire Size		Torque	
	mm <sup>2</sup>	AWG	Nm	lb-ft
All	1.5	16	0.4	0.3

## Efficiency

Approximately 98% at nominal power level.

## Cooling

Cooling Specifications	
<b>Method</b>	Internal fan, flow direction from bottom to top.
<b>Requirement</b>	Free space above and below the ACS550 drive: 200 mm (8 in). Free space is not required on the drive's sides – ACS550 units can be mounted side-by-side.

### *Air Flow, 208...240 Volt Drives*

The following table lists heat loss and air flow data for 208...240 Volt drives.

Drive		Heat Loss		Air Flow	
ACS550-x1-	Frame Size	W	BTU/Hr	m <sup>3</sup> /h	ft <sup>3</sup> /min
-04A6-2	R1	55	189	44	26
-06A6-2	R1	73	249	44	26
-07A5-2	R1	81	276	44	26
-012A-2	R1	116	404	44	26
-017A-2	R1	161	551	44	26
-024A-2	R2	227	776	88	52
-031A-2	R2	285	373	88	52
-046A-2	R3	420	1434	134	79
-059A-2	R3	536	1829	134	79
-075A-2	R4	671	2290	280	165
-088A-2	R4	786	2685	280	165
-114A-2	R4	1014	3463	280	165
-143A-2	R6	1268	4431	405	238
-178A-2	R6	1575	5379	405	238
-221A-2	R6	1952	6666	405	238
-248A-2	R6	2189	7474	405	238

*Air Flow, 380...480 Volt Drives*

The following table lists heat loss and air flow data for 380...500 Volt drives.

Drive		Heat Loss		Air Flow	
ACS550-x1-	Frame Size	W	BTU/Hr	m <sup>3</sup> /h	ft <sup>3</sup> /min
-03A3-4	R1	40	137	44	26
-04A1-4	R1	52	177	44	26
-05A4-4	R1	73	249	44	26
-06A9-4	R1	97	331	44	26
-08A8-4	R1	127	433	44	26
-012A-4	R1	172	587	44	26
-015A-4	R2	232	792	88	52
-023A-4	R2	337	1150	88	52
-031A-4	R3	457	1560	134	79
-038A-4	R3	562	1918	134	79
-044A-4	R4	667	2276	280	165
-059A-4	R4	907	3096	280	165
-072A-4	R4	1120	3820	280	165
-077A-4	R5	1295	4420	168	99
-078A-4	R4	1295	4420	280	165
-096A-4	R5	1440	4915	168	99
-124A-4	R6	1940	6621	405	238
-157A-4	R6	2310	7884	405	238
-180A-4	R6	2810	9590	405	238
-195A-4	R6	3050	10416	405	238

*Air Flow, 500...600 Volt Drives*

The following table lists heat loss and air flow data for 500...600 Volt drives.

Drive		Heat Loss		Air Flow	
ACS550-U1-	Frame Size	W	BTU/Hr	m <sup>3</sup> /h	ft <sup>3</sup> /min
-02A7-6	R2	46	157	88	52
-03A9-6	R2	68	232	88	52
-06A1-6	R2	124	423	88	52
-09A0-6	R2	170	581	88	52
-011A-6	R2	232	792	88	52
-017A-6	R2	337	1150	88	52
-022A-6	R3	457	1560	134	79
-027A-6	R3	562	1918	134	79
-032A-6	R4	667	2276	280	165
-041A-6	R4	907	3096	280	165
-052A-6	R4	1120	3820	280	165
-062A-6	R4	1295	4420	280	165
-077A-6	R6	1504	5136	405	238
-099A-6	R6	1821	6219	405	238
-125A-6	R6	2442	8339	405	238
-144A-6	R6	2813	9607	405	238



## Dimensions and Weights

The dimensions and mass for the ACS550 depend on the frame size and enclosure type. If unsure of frame size, first, find the "Type" code on the drive labels. Then look up that type code in the "Technical Data" on page 216, to determine the frame size. A complete set of dimensional drawings for ACS550 drives is located in the ACS550 Technical Reference manual.

### Mounting Dimensions

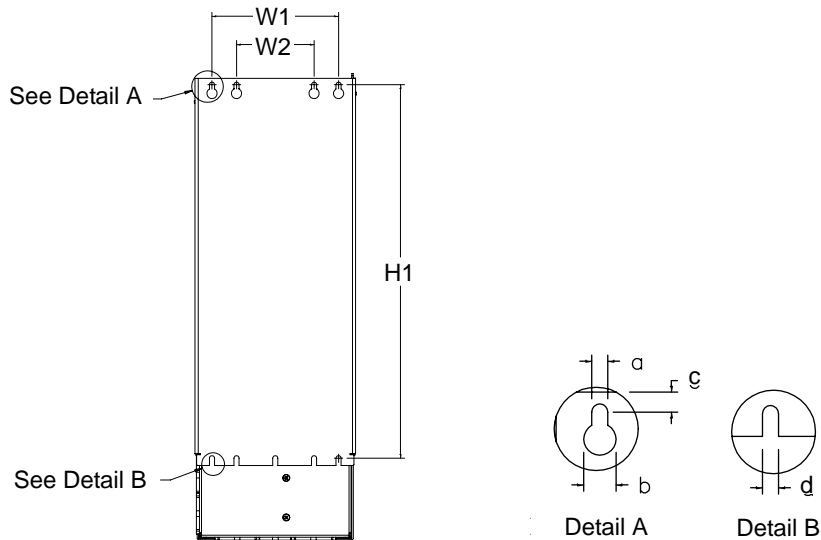

X0032

IP 21 / UL type 1 and IP 54 / UL type 12 – Dimensions for each Frame Size												
Ref.	R1		R2		R3		R4		R5		R6	
	mm	in	mm	in	mm	in	mm	in	mm	in	mm	in
<b>W1*</b>	98.0	3.9	98.0	3.9	160	6.3	160	6.3	238	9.4	263	10.4
<b>W2*</b>	--	--	--	--	98.0	3.9	98.0	3.9	--	--	--	--
<b>H1*</b>	318	12.5	418	16.4	473	18.6	578	22.8	588	23.2	675	26.6
<b>a</b>	5.5	0.2	5.5	0.2	6.5	0.25	6.5	0.25	6.5	0.25	9.0	0.35
<b>b</b>	10.0	0.4	10.0	0.4	13.0	0.5	13.0	0.5	14.0	0.55	14.0	0.55
<b>c</b>	5.5	0.2	5.5	0.2	8.0	0.3	8.0	0.3	8.5	0.3	8.5	0.3
<b>d</b>	5.5	0.2	5.5	0.2	6.5	0.25	6.5	0.25	6.5	0.25	9.0	0.35

\* Center to center dimension.

**Outside Dimensions**

*Units with IP 21 / UL Type 1 Enclosures*

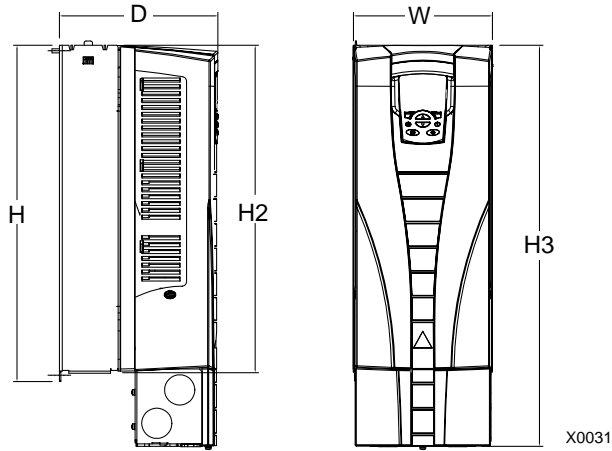

IP 21 / UL type 1 – Dimensions for each Frame Size												
Ref.	R1		R2		R3		R4		R5		R6	
	mm	in	mm	in	mm	in	mm	in	mm	in	mm	in
<b>W</b>	125	4.9	125	4.9	203	8.0	203	8.0	265	10.4	300	11.8
<b>H</b>	330	13.0	430	16.9	490	19.3	596	23.4	602	23.7	700	27.6
<b>H2</b>	315	12.4	415	16.3	478	18.8	583	23.0	578	22.8	698	27.5
<b>H3</b>	369	14.5	469	18.5	583	23.0	689	27.1	739	29.1	880	34.6
<b>D</b>	212	8.3	222	8.7	231	9.1	262	10.3	286	11.3	400	15.8

*Units with IP 54 / UL Type 12 Enclosures*

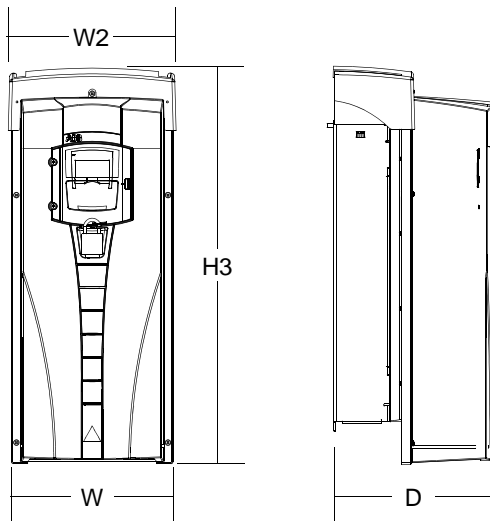

IP 54 / UL type 12 – Dimensions for each Frame Size												
Ref.	R1		R2		R3		R4		R5		R6	
	mm	in	mm	in	mm	in	mm	in	mm	in	mm	in
<b>W</b>	215	8.5	215	8.5	257	10.1	257	10.1	369	14.5	410	16.1

IP 54 / UL type 12 – Dimensions for each Frame Size												
Ref.	R1		R2		R3		R4		R5		R6	
	mm	in	mm	in	mm	in	mm	in	mm	in	mm	in
<b>W2</b>	225	8.9	225	8.9	267	10.5	267	10.5	369	14.5	410	16.1
<b>H3</b>	441	17.4	541	21.3	604	23.8	723	28.5	776	30.5	924	36.4
<b>D</b>	238	9.37	245	9.6	276	10.9	306	12.0	309	12.2	423	16.6

## Weight

The following table lists typical maximum weights for each frame size. Variations within each frame size (due to components associated with voltage/current ratings, and options) are minor.

Enclosure	Weight											
	R1		R2		R3		R4		R5		R6	
	kg	lb.	kg	lb.	kg	lb.	kg	lb.	kg	lb.	kg	lb.
<b>IP 21 / UL type 1</b>	6.5	14.3	9.0	19.8	16	35.0	24	53.0	34	75	69	152
<b>IP 54 / UL type 12</b>	8.2	18.1	11.2	24.7	18.5	40.8	26.5	58.4	38.5	84.9	86	190

## Degrees of Protection

Available enclosures:

- IP 21 / UL type 1 enclosure. The site must be free of airborne dust, corrosive gases or liquids, and conductive contaminants such as condensation, carbon dust, and metallic particles.
- IP 54 / UL type 12 enclosure. This enclosure provides protection from airborne dust and light sprays or splashing water from all directions.

Compared to the IP 21 / UL type 1 enclosure, the IP 54 / UL type 12 enclosure has:

- The same internal plastic shell as the IP 21 enclosure
- A different outer plastic cover
- An additional internal fan to improve cooling.
- Larger dimensions
- The same rating (does not require a derating).

## Ambient Conditions

The following table lists the ACS550 environmental requirements.

Ambient Environment Requirements		
	Installation Site	Storage and Transportation in the protective package
<b>Altitude</b>	<ul style="list-style-type: none"> <li>0...1000 m (0...3,300 ft)</li> <li>1000...2000 m (3,300...6,600 ft) if <math>P_N</math> and <math>I_2</math> derated 1% every 100 m above 1000 m (300 ft above 3,300 ft)</li> </ul>	
<b>Ambient temperature</b>	<ul style="list-style-type: none"> <li>Min. -15 °C (5 °F) – no frost allowed</li> <li>Max. (fsw = 1 or 4) 40 °C (104 °F); 50 °C (122 °F) if <math>P_N</math> and <math>I_2</math> derated to 90%</li> <li>Max. (fsw = 8) 40 °C (104 °F) if <math>P_N</math> and <math>I_2</math> derated to 80%</li> <li>Max. (fsw = 12) 30 °C (86 °F) if <math>P_N</math> and <math>I_2</math> derated to 65% (to 50% for 600 V, R4 frame sizes, that is for ACS550-U1-032A-6 ... ACS550-U1-062A-6)</li> </ul>	-40...70 °C (-40...158 °F)
<b>Relative humidity</b>	< 95% (non-condensing)	
<b>Contamination levels (IEC 721-3-3)</b>	<ul style="list-style-type: none"> <li>No conductive dust allowed.</li> <li>The ACS550 should be installed in clean air according to enclosure classification.</li> <li>Cooling air must be clean, free from corrosive materials and free from electrically conductive dust.</li> <li>Chemical gases: Class 3C2</li> <li>Solid particles: Class 3S2</li> </ul>	<b>Storage</b> <ul style="list-style-type: none"> <li>No conductive dust allowed.</li> <li>Chemical gases: Class 1C2</li> <li>Solid particles: Class 1S2</li> </ul> <b>Transportation</b> <ul style="list-style-type: none"> <li>No conductive dust allowed.</li> <li>Chemical gases: Class 2C2</li> <li>Solid particles: Class 2S2</li> </ul>

The following table lists the standard stress testing that the ACS550 passes.





Stress Tests		
	Without Shipping Package	Inside Shipping Package
<b>Sinusoidal vibration</b>	Mechanical conditions: In accordance with IEC 60721-3-3, Class 3M4 <ul style="list-style-type: none"> <li>2...9 Hz 3.0 mm (0.12 in)</li> <li>9...200 Hz 10 m/s<sup>2</sup> (33 ft/s<sup>2</sup>)</li> </ul>	In accordance with ISTA 1A and 1B specifications.
<b>Shock</b>	Not allowed	In accordance with IEC 68-2-29: max. 100 m/s <sup>2</sup> (330 ft/s <sup>2</sup> ), 11ms (36 fts)
<b>Free fall</b>	Not allowed	<ul style="list-style-type: none"> <li>76 cm (30 in), frame size R1</li> <li>61cm (24 in), frame size R2</li> <li>46 cm (18 in), frame size R3</li> <li>31 cm (12 in), frame size R4</li> <li>25 cm (10 in), frame size R5</li> <li>15 cm (6 in), frame size R6</li> </ul>

## Materials

Material Specifications	
<b>Drive enclosure</b>	<ul style="list-style-type: none"> <li>PC/ABS 2.5 mm, color NCS 1502-Y (RAL 90021 / PMS 420 C and 425 C)</li> <li>Hot-dip zinc coated steel sheet 1.5...2 mm, thickness of coating 20 micrometers</li> <li>Cast aluminium AISi</li> <li>Extruded aluminium AISi</li> </ul>
<b>Package</b>	Corrugated board, expanded polystyrene, plywood, raw wood (heat dried). Package wrap consists of one or more of the following: PE-LD plastic wrap, PP or steel bands.
<b>Disposal</b>	<p>The drive contains raw materials that should be recycled to preserve energy and natural resources. The package materials are environmentally compatible and recyclable. All metal parts can be recycled. The plastic parts can either be recycled or burned under controlled circumstances, according to local regulations. Most recyclable parts are marked with recycling marks.</p> <p>If recycling is not feasible, all parts excluding electrolytic capacitors and printed circuit boards can be landfilled. The DC capacitors contain electrolyte and the printed circuit boards contain lead, both of which will be classified as hazardous waste within the EU. They must be removed and handled according to local regulations.</p> <p>For further information on environmental aspects and more detailed recycling instructions, please contact your local ABB distributor.</p>

## Applicable Standards

Drive compliance with the following standards is identified by the standards "marks" on the type code label.

Mark	Applicable Standards	
	EN 50178 (1997)	Electronic equipment for use in power installations
	EN 60204-1 (1997 + corrigendum Sep. 1998)	Safety of machinery. Electrical equipment of machines. Part 1: General requirements. <i>Provisions for compliance:</i> The final assembler of the machine is responsible for installing: <ul style="list-style-type: none"> <li>An emergency-stop device</li> <li>A supply disconnecting device</li> </ul>
	EN 60529 (1991 + corrigendum May 1993 + amendment A1:2000)	Degrees of protection provided by enclosures (IP code)
	EN 61800-3 (1996) + Amendment A11 (2000)	EMC product standard including specific test methods
	EN 61800-3 (1996) + Amendment A11 (2000)	EMC product standard including specific test methods
	UL 508C	UL Standard for Safety, Power Conversion Equipment, second edition
	C22.2 No. 14	CSA Standard for Industrial Control Equipment

Compliance is valid with the following provisions:

- The motor and control cables are chosen as specified in this manual.

- The installation rules of this manual are followed.

### **UL/CSA Markings**

When a UL mark is attached to the ACS550 AC drive, it verifies that the drive follows the provisions of UL 508C.

When a CSA mark is attached to the ACS550 AC drive, it verifies that the drive follows the provisions of C22.2 No. 14.

The ACS550 is UL and CSA listed to 100 KAIC without use of input fuses or circuit breaker. For end-users convenience, the section "Fuses" provides fuse recommendations. Branch circuit protection must to be provided per local code.

The ACS550 has an electronic motor protection feature that complies with the requirements of UL 508C and CSA C22.2 No. 14. When this feature is selected and properly adjusted, additional overload protection is not required unless more than one motor is connected to the drive or unless additional protection is required by applicable safety regulations. See parameters 3005 (MOT THERM PROT) and 3006 (MOT THERM TIME).

The drives are to be used in a controlled environment. See section "Ambient Conditions" on page 244 for specific limits.

For open type enclosures, units must be mounted inside an enclosure per National Electrical Code and local electrical codes. Open type enclosures are IP21 / UL type 1 units without the conduit box and/or cover, or IP54 / UL type 12 units without the conduit plate and/or top cover.

Brake chopper - ABB has brake choppers that, when applied with appropriately sized brake resistors, will allow the drive to dissipate regenerative energy (normally associated with quickly decelerating a motor).

### **EMC (Europe, Australia, and New Zealand)**

This section describes conformance with EMC requirements (in Europe, Australia, and New Zealand).

#### *CE Marking*

When a CE mark is attached to the ACS550 AC drive, it verifies that the drive follows the provisions of the European Low Voltage and EMC Directives (Directive 73/23/EEC, as amended by 93/68/EEC and Directive 89/336/EEC, as amended by 93/68/EEC). The corresponding declarations are available on request and can be found using the internet at: <http://www.abb.com>.

The EMC Directive defines the requirements for immunity and emissions of electrical equipment used in European Economic Area. The EMC product standard EN 61800-3 covers the requirements stated for drives, such as the ACS550. The drive complies with the First environment (restricted distribution) and Second Environment limits of EN/IEC 61800-3.

#### *C-Tick Marking*

When a C-Tick mark is attached to the ACS550 drive, it verifies compliance with the relevant standard, IEC 61800-3 (1996) – Adjustable speed electrical power drive

systems – Part 3: EMC product standard including specific test methods, mandated by the Trans-Tasman Electromagnetic Compatibility Scheme. The drive complies with the First environment (restricted distribution) and Second Environment limits of EN/IEC 61800-3.

### *Electromagnetic Environments*

Product standard EN 61800-3 (Adjustable speed electrical power drive systems - Part 3: EMC product standard including specific test methods) defines **First Environment** as environment that includes domestic premises. It also includes establishments directly connected without intermediate transformers to a low voltage power supply network which supplies buildings used for domestic purposes.

**Second Environment** includes establishments other than those directly connected to a low voltage power supply network which supplies buildings used for domestic purposes.

## **Liability Limits**

The manufacturer is not responsible for:

- Any costs resulting from a failure if the installation, commissioning, repair, alteration, or ambient conditions of the drive do not fulfil the requirements specified in the documentation delivered with the unit and other relevant documentation.
- Units subjected to misuse, negligence or accident.
- Units comprised of materials provided or designs stipulated by the purchaser.

In no event shall the manufacturer, its suppliers or subcontractors be liable for special, indirect, incidental or consequential damages, losses or penalties.

If you have any questions concerning your ABB drive, please contact the local distributor or ABB office. The technical data, information and specifications are valid at the time of printing. The manufacturer reserves the right to modifications without prior notice.

# Index

<b>Numerics</b>	
0xxxx register	
EFB function codes . . . . .	164
EFB mapping . . . . .	162
1xxxx register	
EFB function codes . . . . .	165
EFB mapping . . . . .	164
3-wire macro . . . . .	44
3xxxx register	
EFB function codes . . . . .	165
EFB mapping . . . . .	165
4xxxx register	
EFB function codes . . . . .	167
EFB mapping . . . . .	165
<b>A</b>	
ABB standard (default) macro . . . . .	43
acceleration	
/deceleration, parameter group . . . . .	95
at aux. stop (PFC), parameter . . . . .	147
compensation, parameter . . . . .	98
ramp select, parameter . . . . .	95
ramp shape, parameter . . . . .	95
ramp time (PFC), parameter . . . . .	147
ramp zero select, parameter . . . . .	96
time, parameter . . . . .	95
activate (external PID), parameter . . . . .	129
actual input (PID), parameters . . . . .	125
actual max. (PID), parameters . . . . .	125
actual min. (PID), parameters . . . . .	125
actual values	
mapping, FBA, generic profile . . . . .	200
scaling, EFB comm . . . . .	157
scaling, FBA . . . . .	188
scaling, FBA, ABB drives profile . . . . .	198
scaling, FBA, generic profile . . . . .	200
alarm	
codes . . . . .	208
codes (Basic control panel) . . . . .	210
enable display, parameter . . . . .	89
listing . . . . .	208
words, data parameters . . . . .	71
alternate macro . . . . .	45
altitude	
derating . . . . .	219
environment limit . . . . .	244
shipping limit . . . . .	244
analog cable	
requirements . . . . .	237
analog I/O	
connections . . . . .	17
specifications . . . . .	17
analog input	
data parameter . . . . .	67
fault limit, parameters . . . . .	106
filter, parameters . . . . .	81
less than min. auto. reset, parameter . . . . .	108
less than min., fault parameter . . . . .	104
loss, fault codes . . . . .	203
maximum, parameters . . . . .	81
minimum, parameters . . . . .	81
parameter group . . . . .	81
ref. correction formula . . . . .	76
analog output	
content max., parameters . . . . .	85
content min., parameters . . . . .	85
current max., parameters . . . . .	85
current min., parameters . . . . .	85
data content, parameters . . . . .	85
data parameter . . . . .	68
filter, parameters . . . . .	85
parameter group . . . . .	85
application block output, data parameter . . . . .	67
application macro, parameter . . . . .	65
application macros	
see macros	
Assistant control panel	
see control panel (Assistant)	
autochange	
interval, parameter . . . . .	140
level, parameter . . . . .	141
overview . . . . .	141
starting order counter . . . . .	141
automatic reset	
see reset, automatic	
auxiliary motor	
see motor, auxiliary	
<b>B</b>	
backing up parameters (Assistant panel) . . . . .	34
backing up parameters (Basic panel) . . . . .	40
battery	
Assistant control panel . . . . .	215
baud rate (RS-232), parameter . . . . .	133
braking	
components . . . . .	232
protection from overheated resistor . . . . .	235
resistor heat dissipation . . . . .	235
selecting brake choppers/resistors . . . . .	232
wiring . . . . .	235
break point frequency, fault parameter . . . . .	105
buffer overruns (count), parameter . . . . .	133
<b>C</b>	
cable requirements	
grounding . . . . .	223
input power . . . . .	222
motor . . . . .	228



CE marking .....	246	comm (FBA)	
changed parameters (Assistant panel) .....	33	actual values .....	183
chopper		analog output control, activate .....	187
see braking		comm fault response .....	188
CISPR11 class A		configuration .....	185
radiation limits .....	230	control interface .....	182
CISPR11 class B		control word .....	182
radiation limits .....	231	control word, ABB drives .....	191
clock setting (Assistant panel) .....	33	diagnostics .....	189
comm		drive feedback .....	188
config file CPI firmware revision, parameter	132	fieldbus control, activate .....	185
config file id revision, parameter .....	132	input ref. sel., activate .....	186
config file revision, parameter .....	132	installation .....	184
fault function, parameter .....	106	overview .....	181
fault time, parameter .....	106	PID control setpoint source, activate .....	188
fieldbus CPI firmware revision, parameter	132	planning .....	183
fieldbus parameter refresh, parameter .....	132	protocol listing .....	181
fieldbus parameters .....	132	reference .....	183
fieldbus status, parameter .....	132	relay output control, activate .....	187
fieldbus type, parameter .....	132	set-up .....	185
protocol select, parameter .....	148	start/stop control, activate .....	185
relay output word, data parameter .....	68	state diagram, ABB drives .....	194
values, data parameter .....	68	status word .....	183
comm (EFB)		status word, ABB drives .....	192
actual value scaling .....	157	compression lugs .....	226
actual values .....	157	conduit	
analog output control, activate .....	155	kit .....	13
comm fault response .....	156	config file	
configuration .....	152	CPI firmware revision, parameter .....	132
configure for loss of communication .....	159	id revision, parameter .....	132
control interface .....	149	revision, parameter .....	132
control word .....	169	connections	
diagnostics .....	158	control .....	17
drive control of functions, activate .....	153	diagram .....	17
exception codes .....	168	EFB comm .....	150
fault code 28 .....	160	FBA module .....	184
fault code 31 .....	160	X1 .....	17
fault code 32 .....	160	constant speed	
fault code 33 .....	160	see speed, constant	
fault tracing parameters .....	158	construction code .....	9
fault, duplicate stations .....	159	contamination levels	
fault, intermittent off-line .....	160	environment limit .....	244
fault, no master station on line .....	159	shipping limit .....	244
fault, swapped wires .....	159	contrast, control panel .....	28
feedback from drive .....	157	control	
input ref. sel., activate .....	154	connection specifications .....	236
installation .....	150	location, data parameter .....	67
misc. drive control, activate .....	154	reference (Assistant panel) .....	30
modbus actual values .....	168	shaft direction .....	30
normal operation .....	159	start/stop .....	30
overview .....	149	terminal specifications .....	237
PID control setpoint source, activate .....	156	control cable	
planning .....	150	connections .....	17
profiles .....	162	requirements .....	236
reference scaling, ABB drives profile .....	178		
relay output control, activate .....	155		
set-up .....	151		
start/stop control, activate .....	153		
state diagram .....	177		
status word .....	172		
termination .....	151		

control panel . . . . .	27	current	
cable requirements . . . . .	237	at fault, history parameter . . . . .	72
comm error, fault parameter . . . . .	104	data parameter . . . . .	67
contrast . . . . .	28	max. limit, parameter . . . . .	90
display bar-graph . . . . .	112	measurement, fault code . . . . .	204
display contrast . . . . .	28	rating code . . . . .	9
display decimal point (form), parameters . . . . .	112		
display max., parameters . . . . .	112	<b>D</b>	
display min., parameters . . . . .	112	dc brake time, parameter . . . . .	94
display process variables, parameter group . . . . .	112	dc bus voltage, data parameter . . . . .	67
display selection, parameters . . . . .	112	dc current ref., parameter . . . . .	94
display units, parameters . . . . .	112	DC magnetizing time, parameter . . . . .	93
parameter lock, parameter . . . . .	86	DC overvoltage, fault code . . . . .	202
pass code, parameter . . . . .	86	DC undervoltage, fault code . . . . .	203
reference control, parameter . . . . .	75	deceleration	
signal max., parameters . . . . .	112	at aux. start (PFC), parameter . . . . .	147
signal min., parameters . . . . .	112	emergency time, parameter . . . . .	95
soft keys . . . . .	28	parameter group . . . . .	95
control panel (Assistant) . . . . .	27	ramp select, parameter . . . . .	95
battery . . . . .	215	ramp shape, parameter . . . . .	95
changed parameters mode . . . . .	33	ramp time (PFC), parameter . . . . .	147
clock set mode . . . . .	33	ramp zero select, parameter . . . . .	96
controls overview . . . . .	28	time, parameter . . . . .	95
fault logger mode . . . . .	33	default macro . . . . .	43
I/O settings mode . . . . .	36	default values	
main menu . . . . .	30	listing for macros . . . . .	51
output mode . . . . .	28	listing for parameters . . . . .	53
parameter backup mode . . . . .	34	derating	
parameters mode . . . . .	31	adjustment example . . . . .	219
rotating arrow . . . . .	29	altitude . . . . .	219
soft key . . . . .	28	single phase supply . . . . .	219
start-up assistant mode . . . . .	31	switching frequency . . . . .	219
control panel (Basic)		temperature . . . . .	219
alarm codes . . . . .	210	derivation time (PID), parameter . . . . .	122
controls overview . . . . .	37	derivation time, parameter . . . . .	97
output mode . . . . .	37	device overtemperature, fault code . . . . .	202
parameter backup mode . . . . .	40	diagnostics . . . . .	201
parameters mode . . . . .	39	EFB comm . . . . .	158
control word		FBA comm . . . . .	189
ABB drives, FBA, description . . . . .	191	differences list, downloads . . . . .	35
comm (EFB), description . . . . .	169	digital cable	
FBA . . . . .	182	requirements . . . . .	237
FBA generic profile . . . . .	199	digital input	
controls overview (Assistant panel) . . . . .	28	at fault, history parameters . . . . .	72
controls overview (Basic panel) . . . . .	37	connections . . . . .	17
cooling		specifications . . . . .	17
air flow . . . . .	238	status, data parameter . . . . .	67
fan maintenance triggers . . . . .	103	digital output	
heat loss . . . . .	238	connections . . . . .	17
space requirement . . . . .	238	specifications . . . . .	236
correction source (PID), parameter . . . . .	130	dimensions	
cover		drive, mounting . . . . .	241
remove . . . . .	11	drive, outside . . . . .	242
replace . . . . .	24	direction	
CRC errors (count), parameter . . . . .	133	control . . . . .	30
critical speeds (avoiding)		control, parameter . . . . .	74
high, parameters . . . . .	100	display format (PID), parameter . . . . .	122
low, parameters . . . . .	100	disposal . . . . .	245
parameter group . . . . .	100	download	
select, parameter . . . . .	100	failure . . . . .	35
CSA marking . . . . .	246	handling inexact transfers . . . . .	34, 41
C-Tick marking . . . . .	246	parameter sets . . . . .	34

drive			
EFB comm installation	150		
FBA module installation	184		
id, fault code	204		
mounting	12		
mounting dimensions	241		
outside dimensions	242		
rating, parameter	111		
temperature, data parameter	67		
weight	243		
drive on time, data parameters	69		
		<b>E</b>	
earth fault			
fault code	204		
parameter	106		
earthing			
see ground			
EFB			
baud rate, parameter	134		
config file, fault code	205		
control profile, parameter	134		
CRC errors (count), parameter	134		
fault codes	205		
ok messages (count), parameter	134		
parameters	134, 135		
parity, parameter	134		
protocol id, parameter	134		
protocol, parameter group	134		
station id, parameter	134		
status, parameter	134		
UART errors (count), parameter	134		
efficiency	238		
EM3 screw	224		
embedded field bus			
see EFB			
EMC			
CE marking	246		
C-Tick marking	246		
motor cable requirements	228		
emergency			
deceleration time, parameter	95		
stop devices	222		
stop select, parameter	94		
EN 61800-3 first environment			
restricted distribution radiation limits	230		
unrestricted distribution radiation limits	231		
enclosure			
types	243		
enclosure protection class code	9		
encoder, data parameters	69		
encoder, parameter group	131		
environment			
first, definition	247		
second, definition	247		
error value inversion (PID), parameter	122		
exception codes, EFB modbus	168		
external comm module, parameter group	132		
external commands selection, parameter	73		
external control selection, parameter	75		
external fault			
automatic reset, parameter	108		
fault codes	203		
parameters	104		
external reference, data parameter	67		
		<b>F</b>	
fan maintenance	213		
fault			
codes	202		
comm (FBA)	188		
comm failure (EFB)	156		
current at, history parameter	72		
digital input status at, history parameter	72		
frequency at, history parameter	72		
functions, parameter group	104		
history	207		
history, parameter group	72		
last, history parameter	72		
listing	202		
previous, history parameter	72		
reset	207		
reset select, parameter	86		
speed at, history parameter	72		
status at, history parameter	72		
time of, history parameters	72		
torque at, history parameter	72		
voltage at, history parameter	72		
words, data parameters	71		
fault code			
28 serial 1 err	160		
fault logging (Assistant panel)	33		
FB actual signals, parameter group	70		
feedback multiplier (PID), parameter	124		
feedback select (PID), parameter	124		
field weakening point	227		
fieldbus			
see comm			
command words, data parameters	70		
CPI firmware revision, parameter	132		
parameter refresh, parameter	132		
parameters	132		
status words, data parameters	70		
status, parameter	132		
type, parameter	132		
fieldbus adapter			
see comm (FBA)			
firmware test date, parameter	111		
firmware version, parameter	111		
first environment, definition	247		
first start			
calibration description	66		
floating network			
connections	224		
warning about filters	230, 231		
warning about screws at EM1, EM3	15		
warning about screws at F1, F2	16		
flux braking, parameter	101		
flux optimization, parameter	101		
force trip, fault code	205		
frame errors (count), parameter	133		
frame size	216		

free fall			
stress testing . . . . .	244		
frequency			
at fault, history parameter . . . . .	72		
max. limit, parameter . . . . .	91		
min. limit, parameter . . . . .	91		
motor, resolution . . . . .	227		
motor, specification . . . . .	227		
switching, parameter . . . . .	101		
fuses			
208...240 volt drives . . . . .	221		
380...480 volt drives . . . . .	221		
500...600 volt drives . . . . .	222		
<b>G</b>			
gain (PID), parameter . . . . .	121		
generic profile			
actual value mapping . . . . .	200		
actual value scaling . . . . .	200		
overview . . . . .	199		
reference scaling . . . . .	199		
technical data . . . . .	199		
gland kit . . . . .	13		
ground			
cable/wire requirements . . . . .	223		
fault protection . . . . .	227		
<b>H</b>			
hand-auto macro . . . . .	47		
heat loss . . . . .	238		
<b>I</b>			
I/O settings (Assistant panel) . . . . .	36		
id run			
calibration description . . . . .	66		
id run fail, fault code . . . . .	203		
IEC ratings			
see ratings			
impedance grounded network			
see floating network			
information			
parameter group . . . . .	111		
input power			
cable/wire requirements . . . . .	222		
disconnect device . . . . .	220		
specifications . . . . .	220		
input power connection			
floating networks			
lugs for R6 . . . . .	225		
terminal size . . . . .	225		
torque . . . . .	225		
installation			
check list . . . . .	23		
compatibility . . . . .	9		
environment . . . . .	10		
flow chart . . . . .	7		
location . . . . .	10		
mounting drive . . . . .	12		
preparation . . . . .	8		
procedures . . . . .	7		
tools . . . . .	9		
wiring overview . . . . .	13		
insulation			
check . . . . .	18		
integration time (PID), parameter . . . . .	122		
integration time, parameter . . . . .	97		
interlocks			
parameter . . . . .	142		
internal setpoint (PID), parameter . . . . .	124		
IR compensation			
frequency, parameter . . . . .	101		
parameters . . . . .	101		
voltage, parameter . . . . .	101		
IT network			
see floating network			
<b>K</b>			
keypad			
see control panel			
keypad reference select, parameter . . . . .	75		
kWh counter, data parameter . . . . .	67		
<b>L</b>			
label			
serial number . . . . .	8		
type code . . . . .	8		
language, parameter . . . . .	65		
liability limits . . . . .	247		
limits, parameter group . . . . .	90		
load package version, parameter . . . . .	111		
LOC/REM			
Assistant panel . . . . .	29		
Basic panel . . . . .	38		
local control . . . . .	29		
local mode			
lock, parameter . . . . .	87		
lock			
control panel access, IP54 . . . . .	24		
drive control at local control panel . . . . .	87		
parameters . . . . .	86		
low frequency (PFC), parameters . . . . .	138		
lugs for R6 power cables . . . . .	225		

**M**

macros	
3-wire	44
ABB standard (default)	43
alternate	45
hand-auto	47
motor potentiometer	46
parameter default values	51
parameters not changed	
PFC	49
PID control	48
torque control	50
main menu	
control panel (Assistant)	30
mains	
see input power	
maintenance	
capacitors	214
control panel	215
heat sink	212
internal enclosure fan	214
intervals	212
main fan	213
triggers, parameter group	103
manuals	2
mapping	
actual value, FBA, generic profile	200
EFB modbus	162
materials	245
maximum	
frequency, parameter	91
torque limit, parameters	92
torque select, parameter	91
minimum	
frequency, parameter	91
torque limit, parameters	91
torque select, parameter	91
modbus	
EFB addressing, convention	162
EFB coils	162
EFB discrete inputs	164
EFB holding registers	165
EFB input registers	165
EFB mapping details	162
EFB mapping summary	162
EFB supported features	161
EFB technical data	161

motor	
changing rotation	25
characteristics, first start	66
characteristics, id run	66
checking insulation	18
compatibility	9
connection specifications	227
id run, parameter	66
load curve break point frequency	105
load curve max., fault parameter	105
load curve zero speed load	105
maintenance triggers	103
nominal current, parameter	65
nominal frequency, parameter	65
nominal power, parameter	66
nominal speed, parameter	66
nominal voltage, parameter	65
phase, fault code	205
requirements	9
stall, fault code	203
motor cable	
checking insulation	18
max. length	227
requirements	228
requirements, EMC	228
motor connection	
lugs for R6	225
terminal size	225
torque	225
motor control	
control mode, parameter	65
IR compensation, parameters	101
parameter group	101
motor potentiometer macro	46
motor temperature	
alarm limit, parameter	115
data parameter	69
fault limit, parameter	115
measure, parameter group	114
overtemperature, fault code	203
sensor selection, parameter	115
sensor type, parameter	115
thermal protection, fault parameter	104
thermal time, fault parameter	104
motor, auxiliary	
aux. start delay (PFC), parameter	138
aux. stop delay (PFC), parameter	138
number of aux., parameter	139
mounting	
dimensions	241
MWh counter, data parameter	69

**N**

NEMA ratings	
see ratings	
noise	
random sw. freq. parameter	102
NPN	18

**O**

offset (PID), parameter	129
ok messages (count), parameter	133



PTC temperature sensor . . . . .	115	RS-232 counts	
pump fan control		buffer overruns, parameter . . . . .	133
see PFC		CRC errors, parameter . . . . .	133
		frame errors, parameter . . . . .	133
		ok messages, parameter . . . . .	133
		parity errors, parameter . . . . .	133
		RS485 comm . . . . .	150
		run enable	
		source select, parameter . . . . .	86
		run time, data parameter . . . . .	67, 69
		<b>S</b>	
		safety . . . . .	3
		save changes parameter . . . . .	87
		scalar: speed mode . . . . .	65
		scaling	
		actual value, FBA, ABB drives profile . . . . .	198
		actual value, FBA, generic profile . . . . .	200
		actual values, EFB comm . . . . .	157
		reference (EFB, ABB drives profile) . . . . .	178
		reference, FBA, ABB drives profile . . . . .	195
		reference, FBA, generic profile . . . . .	199
		s-curve ramp, parameter . . . . .	95
		sensor type, parameter . . . . .	115
		sensorless vector control mode . . . . .	65
		serial 1 error (fault code 28) . . . . .	160
		serial 1 error, fault code . . . . .	205
		serial communication	
		see comm	
		serial number . . . . .	8
		setpoint maximum (PID), parameter . . . . .	124
		setpoint minimum (PID), parameter . . . . .	124
		setpoint select (PID), parameter . . . . .	123
		shock	
		stress testing . . . . .	244
		short circuit, fault code . . . . .	203
		single phase supply	
		connection . . . . .	13
		derating . . . . .	219
		sleep selection (PID), parameter . . . . .	126
		slip compensation ratio, parameter . . . . .	102
		soft key . . . . .	28
		soft keys, control panel . . . . .	28
		specifications	
		control connections . . . . .	236
		input power . . . . .	220
		mains . . . . .	220
		motor connections . . . . .	227
		speed	
		at fault, history parameter . . . . .	72
		data parameter . . . . .	67
		max. limit, parameter . . . . .	90
		min. limit, parameter . . . . .	90
		speed control	
		acceleration compensation, parameter . . . . .	98
		automatic tuning, parameter . . . . .	97, 98
		derivation time, parameter . . . . .	97
		integration time, parameter . . . . .	97
		parameter group . . . . .	97
		proportional gain, parameter . . . . .	97
		vector: speed mode . . . . .	65
radiation limits, conducted			
EN 61800-3 . . . . .	229		
ramp pair (accel/decel), parameter . . . . .	95		
range			
listing for parameters . . . . .	53		
ratings . . . . .	216		
reference			
analog input corrections . . . . .	76		
corrections for parameter values . . . . .	76		
keypad control, parameter . . . . .	75		
maximum, parameters . . . . .	77		
minimum, parameters . . . . .	77		
select source, parameter . . . . .	75		
select, parameter group . . . . .	75		
speed/frequency control (Assistant panel) . . . . .	30		
reference scaling			
EFB, ABB drives profile . . . . .	178		
FBA, ABB drives profile . . . . .	195		
FBA, generic profile . . . . .	199		
reference step (PFC), parameters . . . . .	136		
regulator by-pass control, parameter . . . . .	146		
relative humidity			
environment limit . . . . .	244		
shipping limit . . . . .	244		
relay output			
activation condition parameters . . . . .	82		
off-delay, parameters . . . . .	83		
on-delay, parameters . . . . .	83		
parameter group . . . . .	82		
status, data parameter . . . . .	68		
relays, specifications . . . . .	236		
remote control . . . . .	29		
remove cover . . . . .	11		
reset, automatic			
analog input less than min., parameter . . . . .	108		
delay time, parameter . . . . .	108		
external fault, parameter . . . . .	108		
number of trials, parameter . . . . .	108		
overcurrent, parameter . . . . .	108		
parameter group			
trial time, parameter . . . . .	108		
undervoltage, parameter . . . . .	108		
resolution			
listing for parameters . . . . .	53		
resonance (avoiding)			
select, parameter . . . . .	100		
revolution counter, data parameter . . . . .	69		
ring lugs . . . . .	225		
rotating arrow, control panel . . . . .	29		
RS-232			
baud rate, parameter . . . . .	133		
parity, parameter . . . . .	133		
station id, parameter . . . . .	133		





trim mode (PID), parameter . . . . .	129
trim scale (PID), parameter . . . . .	129
type code . . . . .	8

**U**

U/f ratio, parameter . . . . .	101
UL marking . . . . .	246
underload	
curve, fault parameter . . . . .	106
fault code . . . . .	204
function, fault parameter . . . . .	106
time, fault parameter . . . . .	106
undervoltage	
automatic reset, parameter . . . . .	108
control enable, parameter . . . . .	90
ungrounded network	
see floating network	
units (PID), parameter . . . . .	122
unpacking drive . . . . .	8
unsymmetrically grounded networks . . . . .	224
user parameter set	
change control, parameter . . . . .	87
download . . . . .	34

**V**

vibration	
stress testing . . . . .	244
voltage	
at fault, history parameter . . . . .	72
rating code . . . . .	9
voltage/frequency ratio, parameter . . . . .	101

**W**

wake-up delay (PID), parameter . . . . .	126
wake-up deviation (PID), parameter . . . . .	126
warning	
automatic start up . . . . .	3, 25
dangerous voltages . . . . .	3
high temperatures . . . . .	3
listing . . . . .	3
not field repairable . . . . .	3
parallel control connections . . . . .	3
qualified installer . . . . .	3
thermistor installation . . . . .	114
weight	
drive . . . . .	243
wiring	
control . . . . .	17
fault, parameter . . . . .	107
installation . . . . .	18
installation steps, IP21/cables . . . . .	19
installation steps, IP21/conduit . . . . .	20
installation steps, IP54/cables . . . . .	21
installation steps, IP54/conduit . . . . .	22
overview . . . . .	13
requirements, general . . . . .	13

**XYZ**

zero speed load, fault parameter . . . . .	105
--	-----



ACS550-US-04  
3AJUA000001418 REV E / EN  
EFFECTIVE: DEC 6, 2004  
SUPERSEDES: JUNE 24, 2004

---

**ABB Oy**

AC Drives

P.O. Box 184

FIN-00381 HELSINKI

FINLAND

Telephone +358 10 22 11

Telefax +358 10 22 22681

Internet <http://www.abb.com>

**ABB Inc.**

Automation Technologies

Drives & Machines

16250 West Glendale Drive

New Berlin, WI 53151

USA

Telephone +1 262 785-3200

+1 800 HELP-365

Telefax +1 262 780-5135